

T-0910 Pik Döküm / Cast Iron

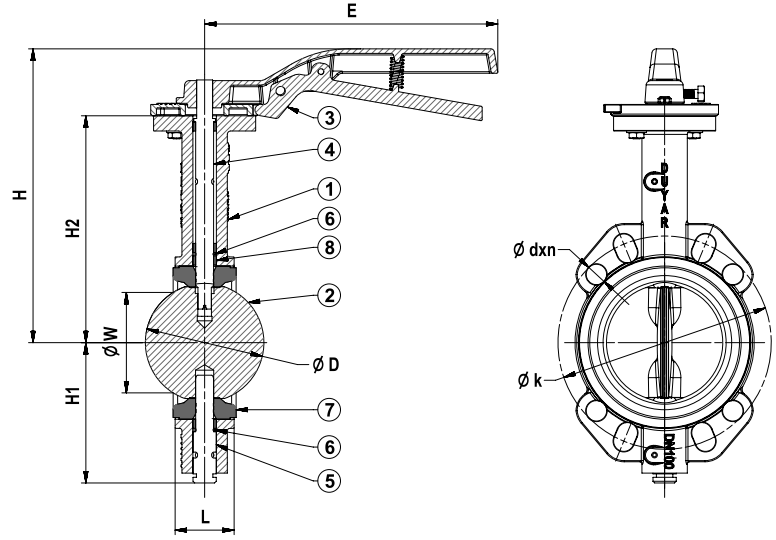

### Genel Özellikler / General Specifications

Çalışma Sıcaklık Aralığı / Working Temperature : -10 ... +110 °C (16 Bar)

### Standartlar / Standards

Sertifikalar / Certificates :

Tasarım / Design : TS EN 593

Bağlantı Boyutları / Connection Dimensions : TS EN 1092-2 (PN 6 / 10 / 16)

Testler / Tests : TS EN 12266-1

### Uygulamalar / Applications

HVAC sistemleri, arıtma tesisleri, kağıt endüstrisi, tatlı su tesisatları  
HVAC systems, water treatment systems, paper industry, fresh water system

No	Parça Adı / Part Name	Malzeme / Material
1	Gövde / Body	GG 25 - EN GJL 250 - Pik Döküm / Cast Iron
2	Klape + Kaplama / Clapper + Plated	GGG 40 - EN GJS 400-15 - Sfero Döküm + Nikel Kaplama / Ductile Iron + Nickel Plated
3	Kol / Lever	GGG 40 - EN GJS 400-15 - Sfero Döküm / Ductile Iron
4	Üst Mil / Top Stem	X20Cr13 - AISI420 - Paslanmaz Çelik / Stainless Steel
5	Alt Mil / Bottom Stem	X20Cr13 - AISI420 - Paslanmaz Çelik / Stainless Steel
6	O-Ring	EPDM
7	Conta / Seat	EPDM - NBR
8	Mil Yatağı / Stem Bearing	Yağlı Bronz / Lubricated Bronze

Anma Basıncı / Nominal Pressure	16 Bar																				
	Anma Çapı / Nominal Diameter	DN	40	50	65	80	100	125	150	200	250	300	350	400	450	500	600				
Vana Boyutları / Valve Dimensions	L	33	43	46	52	56	60	68	78	102	114	127	154	Dişli Kutuludur / With Gear Box							
	E	210				265			355	Dişli Kutuludur / With Gear Box											
	H1	77	81	87	99	111	132	144	185	208	251	277	308	342	374	459					
	H2	144	162	175	193	200	218	226	280	315	354	388	416	455	490	562					
	H	205	222	235	253	260	288	296	340	Dişli Kutuludur / With Gear Box											
	W	26.8	31	45.9	62.2	90.6	110	145.6	193.9	241.6	292.3	341.8	388.8	445.6	480.5	566.4					
	D	42.5	53	65	79	104.5	123.5	156	203	251	302.5	354	402	455	492.5	582					
	k	110	125	145	160	180	210	240	295	355	410	470	525	585	650	770					
	dxn	19x4			19x8			23x8	23x12	28x12	28x16	31x16	31x20	34x20	37x20						
	Tepe Flanş / Upper Flange	(ISO 5211) F05				(ISO 5211) F07				(ISO 5211) F10				(ISO 5211) F16							
Mil Ölçüsü / Stem Dimension	□11				□14				□17				□22				Ø31,8	Ø33,3	Ø38,1	Ø41,3	Ø50,8
Ağırlık / Weight	Kg	2,5	3	3,5	4	6	7	9	14	20	33	49	90	110	150	242					