

PASLANMAZ ÇELİK KÜRESEL VANA (FLANŞLI 2 PARÇALI PN 10)

-STAINLESS STEEL BALL VALVE (FLANGED 2 PCS PN 10)

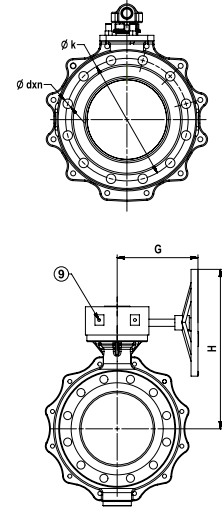

T-0650 Paslanmaz Çelik Döküm / Cast Stainless Steel

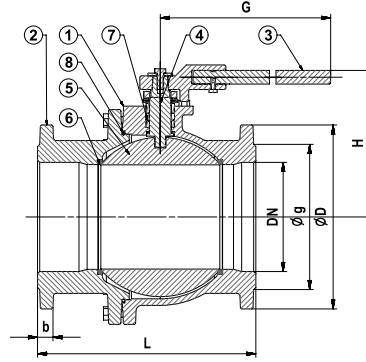

Genel Özellikler / General Specifications

Çalışma Sıcaklık Aralığı / Working Temperature : -10... +120 °C (10 Bar)

Standartlar / Standards

Sertifikalar / Certificates : CE

Tasarım / Design : TS 3148, EN ISO 17292

Flanş Boyutları / Flange Dimensions : TS EN 1092-1 (DN 200-250 PN 10)

Alından Alına Boyutlar / Face to Face Dimensions : TS EN 558 (Seri 15)

DN 200-250

Testler / Tests : TS EN 12266-1

Uygulamalar / Applications

Sıcak ve soğuk su sistemleri, kızgın su, basınçlı hava, soğutma yağı, deniz suyu
Hot and cold water systems, superheated water, compressed air, cooling oil, sea water

Malzeme Özellikleri / Material Specifications	No	Parça Adı / Part Name	Malzeme / Material
	1	Gövde / Body	G-X6CrNiMo18 10 - CF8M - Paslanmaz Çelik / Cast Stainless Steel
	2	Flanş / Flange	G-X6CrNiMo18 10 - CF8M - Paslanmaz Çelik / Cast Stainless Steel
	3	Kol / Lever	X5CrNi18 10 - AISI304 - Paslanmaz Çelik / Stainless Steel
	4	Mil / Stem	X6CrNiMo18 10 - CF8M-Paslanmaz Çelik / Stainless Steel
	5	Küre / Ball	G-X6CrNiMo18 10 - CF8M - Paslanmaz Çelik / Cast Stainless Steel
	6	Ringler / Seals	PTFE - Teflon
	7	Salmastra / Packing	PTFE - Teflon
8	Conta / Gasket	PTFE - Teflon	

Ölçüler / Dimensions	Anma Basıncı / Nominal Pressure	10 Bar		
	Anma Çapı / Nominal Diameter	DN		
	Vana Boyutları / Valve Dimensions		200	250
			400	450
			Dişli Kutuludur / With Gear Box	
			340	395
			295	350
			24	26
		dxn	23x8	23x12
Ağırlık / Weight	kg	136	189,4	