

EBARA

	Page
- SPECIFICATIONS	200
SELECTION CHART	201
SELECTION CHART	202
TYPE KEY AND CURVE SPECIFICATIONS	203
PERFORMANCE CURVE 4N1	205
PERFORMANCE CURVE 4N2	206
PERFORMANCE CURVE 4N4	207
PERFORMANCE CURVE 4N7	208
PERFORMANCE CURVE 4N10	209
PERFORMANCE CURVE 4N15	210
- CONSTRUCTIONS	300
SECTIONAL VIEW (4N1 – 4N2 – 4N4)	300
SECTIONAL VIEW 4N7	301
SECTIONAL VIEW 4N10	302
SECTIONAL VIEW 4N15	303
SECTIONAL VIEW TABLE	304
QUANTITY FOR MODEL	305
- DIMENSIONS AND WEIGHT	400
PUMP DRAWING	400
DIMENSIONS PUMP TABLE	401
PACKING	402
- TECHNICAL DATA	500
OIL – WATER MOTOR FILLED	500
OIL FILLED MOTORS CABLE SELECTION	501
WATER FILLED MOTORS CABLE SELECTION	502

SPECIFICATION

50Hz

Rev. G

PUMP		
Liquid Handled	Type of liquid	Clean water
	Temperature [°C]	Maximum 40 (depends on maximum temperature motor)
	Sand content	Maximum : 50 parts per million
	Chlorine ion density	Maximum : 500 parts per million
Construction	Impeller	Closed centrifugal - Face clearance type
	Bearing	Sleeve type - Alumina (Ceramic) / EPDM rubber
Pipe connection	Suction	N/A
	Discharge	G1 1/4 (models 4N1, 4N2, 4N4) UNI ISO 228 G2 (models 4N7, 4N10, 4N15) UNI ISO 228
Material	Impeller	Ixef® (models 4N1, 4N2, 4N4, 4N7)
		Glass Fibre Reinforced PC (models 4N10, 4N15)
	Intermediate casing	EN 1.4301 (AISI 304)
	Diffuser	PPE+PS Glass Fibre Reinforced
	Shaft	EN 1.4301 (AISI 304)
	Discharge casing	EN 1.4308 (ASTM CF8)
	Valve	EN 1.4301 (AISI 304)
Bracket	EN 1.4308 (ASTM CF8)	
Applicable standard of test		ISO 9906 - Annex A

MOTOR				
Type	Submersible oil filled (type OY)		Submersible water filled (type WY)	
Manufacturer	Sumoto		Franklin	
	Single phase	Three phase	Single phase	Three phase
Power rating	[kW]	0.37÷2.2	0.37÷7.5	0.37÷2.2
	[HP]	0.5÷3.0	0.5÷10	0.5÷3.0
No. of Poles	2			
Rated speed	Refer to each characteristic performance rotation speed as rated speed			
Insulation class	F		B	
Protection degree	IP 68		IP 68	
Maximum ambient temperature [°C]	35		30	
Maximum immersion [m]	150		350	
Starts / hours	30		20	
Start type	Direct on line			
Frequency [Hz]	50 Hz			
Voltage [V]	230 ±10%	380-415 ±10%	230 -10%+6%	380-415 -10%+6%
Capacitor for start and run	Fitted in starter box	-	Fitted in starter box	-
Over load protection	Fitted in starter box	Provided by the user	Fitted in starter box	Provided by the user
Sealing liquid	Oil type: Marcol 82 (Esso)		Propylene Glycol 50% water solution	
Motor bracket	Cast iron nickel plated		EN 1.4301 (AISI 304)	
Casing material	EN 1.4301 (AISI 304)			
Power cable	material	EPDM/Cross Seald Polyethylene		
	size [mm ²]	4x1.5		
	length [m]	L=1.75 (up to 2.2 kW) / L=2.5 (for 3 and 4 kW) / L=4 (for 5.5 and 7.5 kW)		
Flange mount	NEMA standard			

SELECTION CHART

50Hz

Rev. G

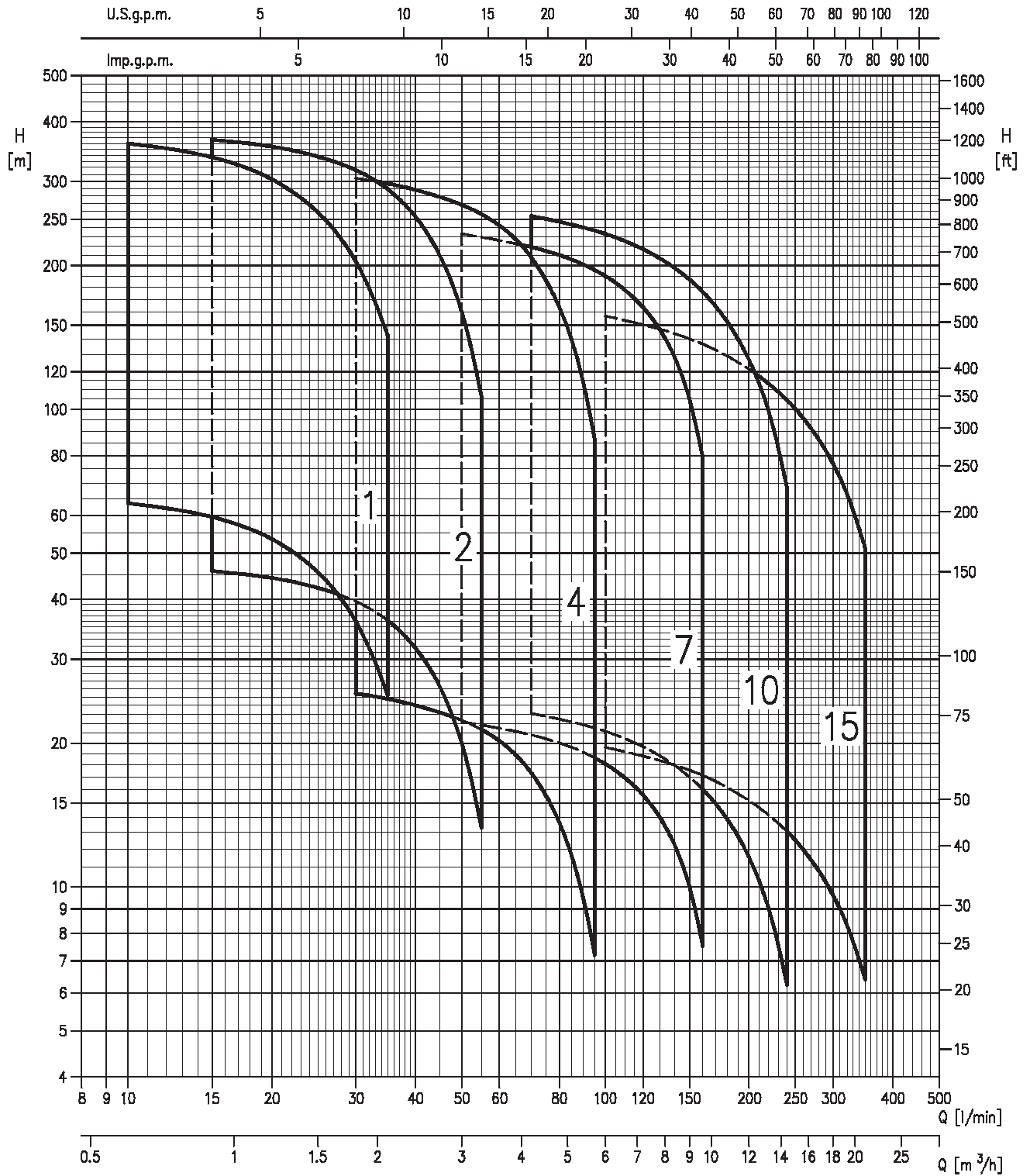

SELECTION CHART

50Hz

Rev. G

Pump type	Power		Q=Capacity										
			l/min	10	15	20	25	30	35	45	55	75	95
	[kW]	[HP]	m ³ /h	0.6	0.9	1.2	1.5	1.8	2.1	2.7	3.3	4.5	5.7
			H=Total Head										
4N1- 12	0.37	0.5	66.5	63.5	59.5	53.5	45.5	36	25.2	-	-	-	-
4N1- 18	0.55	0.7	100	95.5	89.5	80.5	68.5	54	37.8	-	-	-	-
4N1- 24	0.75	1.0	133	127	119	107	91	72	50.5	-	-	-	-
4N1- 34	1.10	1.5	189	180	169	152	129	102	71.5	-	-	-	-
4N1- 48	1.50	2.0	266	254	238	214	182	144	101	-	-	-	-
4N1- 68	2.20	3.0	377	360	337	303	258	204	142	-	-	-	-
4N2- 7	0.37	0.5	48.5	-	46	44.5	42.5	39.6	36.1	26.2	13.3	-	-
4N2- 10	0.55	0.7	69.3	-	65.5	63.5	60.5	56.5	51.5	37.5	19	-	-
4N2- 14	0.75	1.0	97	-	91.5	89	84.5	79	72	52.5	26.6	-	-
4N2- 20	1.10	1.5	139	-	131	127	121	113	103	75	38	-	-
4N2- 28	1.50	2.0	194	-	183	178	169	158	144	105	53	-	-
4N2- 40	2.20	3.0	277	-	262	254	242	226	206	150	76	-	-
4N2- 56	3.00	4.0	388	-	367	355	338	317	289	210	106	-	-
4N4- 4	0.37	0.5	27.8	-	-	-	-	25.4	24.8	23.2	21.4	15.5	7.2
4N4- 7	0.55	0.7	48.7	-	-	-	-	44.45	43.33	40.6	37.38	27.23	12.6
4N4- 9	0.75	1.0	62.6	-	-	-	-	57	55.5	52	48	35	16.2
4N4- 13	1.10	1.5	90.4	-	-	-	-	82.5	80.5	75.5	69.5	50.5	23.4
4N4- 18	1.50	2.0	125	-	-	-	-	114	111	104	96	70	32.4
4N4- 27	2.20	3.0	188	-	-	-	-	171	167	157	144	105	48.5
4N4- 36	3.00	4.0	250	-	-	-	-	229	223	209	192	140	65
4N4- 48	4.00	5.5	334	-	-	-	-	305	297	278	256	187	86.5

Pump type	Power		Q=Capacity										
			l/min	50	70	100	130	160	200	240	280	320	350
	[kW]	[HP]	m ³ /h	3.0	4.2	6.0	7.8	9.6	12.0	14.4	16.8	19.2	21.0
			H=Total Head										
4N7- 4	0.55	0.7	24.8	22.2	20.8	18.1	14	7.5	-	-	-	-	-
4N7- 6	0.75	1.0	37.2	33.3	31.2	27.1	21	11.3	-	-	-	-	-
4N7- 8	1.10	1.5	49.5	44.5	41.5	36.2	28	15	-	-	-	-	-
4N7- 12	1.50	2.0	74.5	66.5	62.5	54.5	42	22.6	-	-	-	-	-
4N7- 17	2.20	3.0	105	94.5	88.5	77	59.5	32	-	-	-	-	-
4N7- 23	3.00	4.0	143	128	120	104	80.5	43.5	-	-	-	-	-
4N7- 30	4.00	5.5	186	166	156	136	105	56.5	-	-	-	-	-
4N7- 42	5.50	7.5	260	233	219	190	147	79	-	-	-	-	-
4N10- 4	0.75	1.0	25.7	-	23.1	21.2	18.8	16	11.5	6.2	-	-	-
4N10- 6	1.10	1.5	38.6	-	34.6	31.8	28.2	24	17.3	9.4	-	-	-
4N10- 8	1.50	2.0	51.5	-	46.2	42.5	37.7	32	23.1	12.5	-	-	-
4N10- 13	2.20	3.0	83.5	-	75	69	61	52	37.5	20.3	-	-	-
4N10- 17	3.00	4.0	109	-	98	90	80	68	49	26.5	-	-	-
4N10- 23	4.00	5.5	148	-	133	122	108	92	66.5	35.8	-	-	-
4N10- 32	5.50	7.5	206	-	185	170	151	128	92	50	-	-	-
4N10- 44	7.50	10.0	283	-	254	233	207	176	127	68.5	-	-	-
4N15- 4	1.10	1.5	25.5	-	-	23.5	22.4	21	18.9	16.3	13.3	9.8	7
4N15- 6	1.50	2.0	38.3	-	-	35.3	33.6	31.5	28.3	24.4	19.9	14.7	10.5
4N15- 8	2.20	3.0	51.1	-	-	47	45	42	37.7	32.5	26.5	19.6	14
4N15- 11	3.00	4.0	72.2	-	-	67.5	65	61.5	56	49.5	41.9	33.2	25.9
4N15- 14	4.00	5.5	91.9	-	-	86	82.5	78	71.5	63	53.5	42	33
4N15- 20	5.50	7.5	131	-	-	123	118	112	102	90	76	60.5	47
4N15- 27	7.50	10.0	177	-	-	166	159	151	137	121	103	81.5	63.5

TYPE KEY

EXAMPLE (pump without motor) :

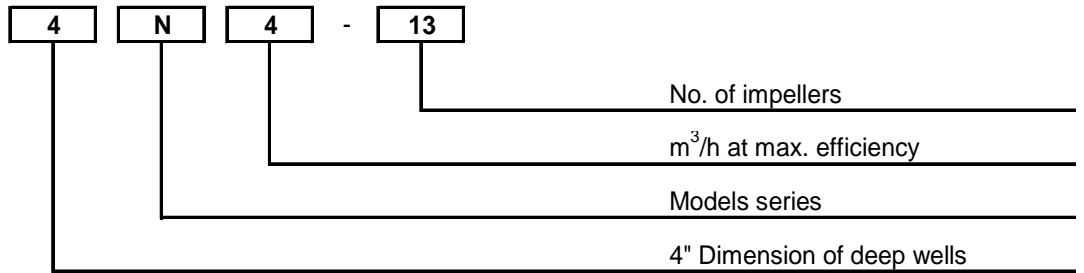

EXAMPLE (pump with motor) :

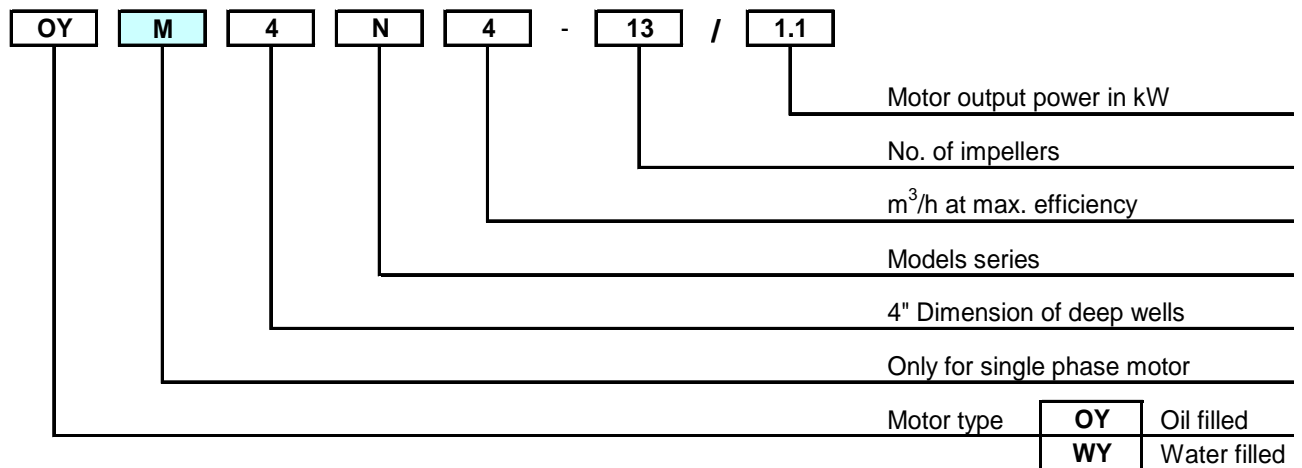

PERFORMANCE CURVE SPECIFICATIONS

The specifications below qualify the curves shown on the following pages.

Tolerances according to ISO 9906 Annex A

The curves refer to effective speed of asynchronous motors at 50 Hz

Measurements were carried out with clean water at 20°C of temperature and with a kinematic viscosity of $\nu = 1 \text{ mm}^2/\text{s}$ (1 cSt)

The continuous curves indicate the recommended working range. The dotted curve is only a guide.

In order to avoid the risk of over-heating, the pumps should not be used at a flow rate below 10% of best efficiency point.

Symbols explanation:

- Q = volume flow rate
- H = total head
- P_2 = pump power input (shaft power)
- η = pump efficiency
- NPSH = net positive suction head required by the pump
- MEI = minimum efficiency index

The minimum efficiency index (MEI) is a measure of the quality of a pump size in respect to its mean efficiency. The minimum efficiency index is based on the hydraulic efficiency and on the head at the best efficiency point.

The efficiency of a pump with trimmed impeller is usually lower than that of a pump with the full impeller diameter. The trimming of the impeller will adapt the pump to a fixed duty point, leading to reduced energy consumption. The minimum efficiency index (MEI) is based on the full impeller diameter.

The operation of these water pumps with variable duty points may be more efficient and economic when controlled, for example, by the use of a variable speed drive that matches the pump duty to the system.

MEI = 0.4 for Multistage Submersible 2900rpm

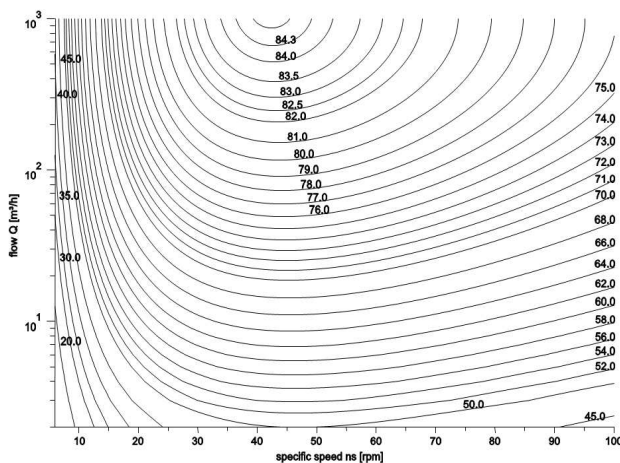

MEI = 0.7 for Multistage Submersible 2900 rpm

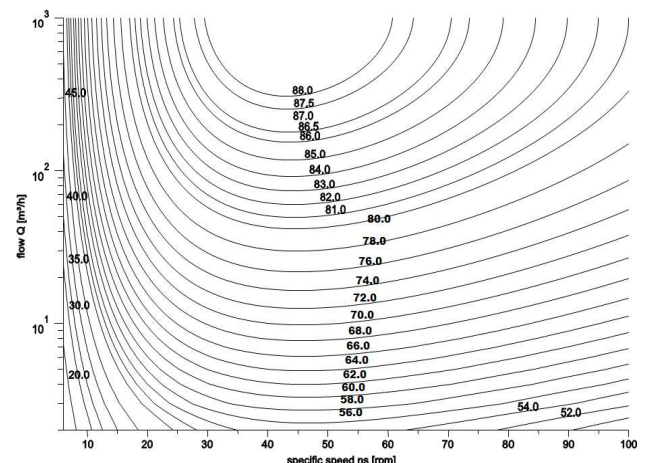

WINNER 4N1 - MEI > 0.70 - Impeller diameter = 67.6 mm

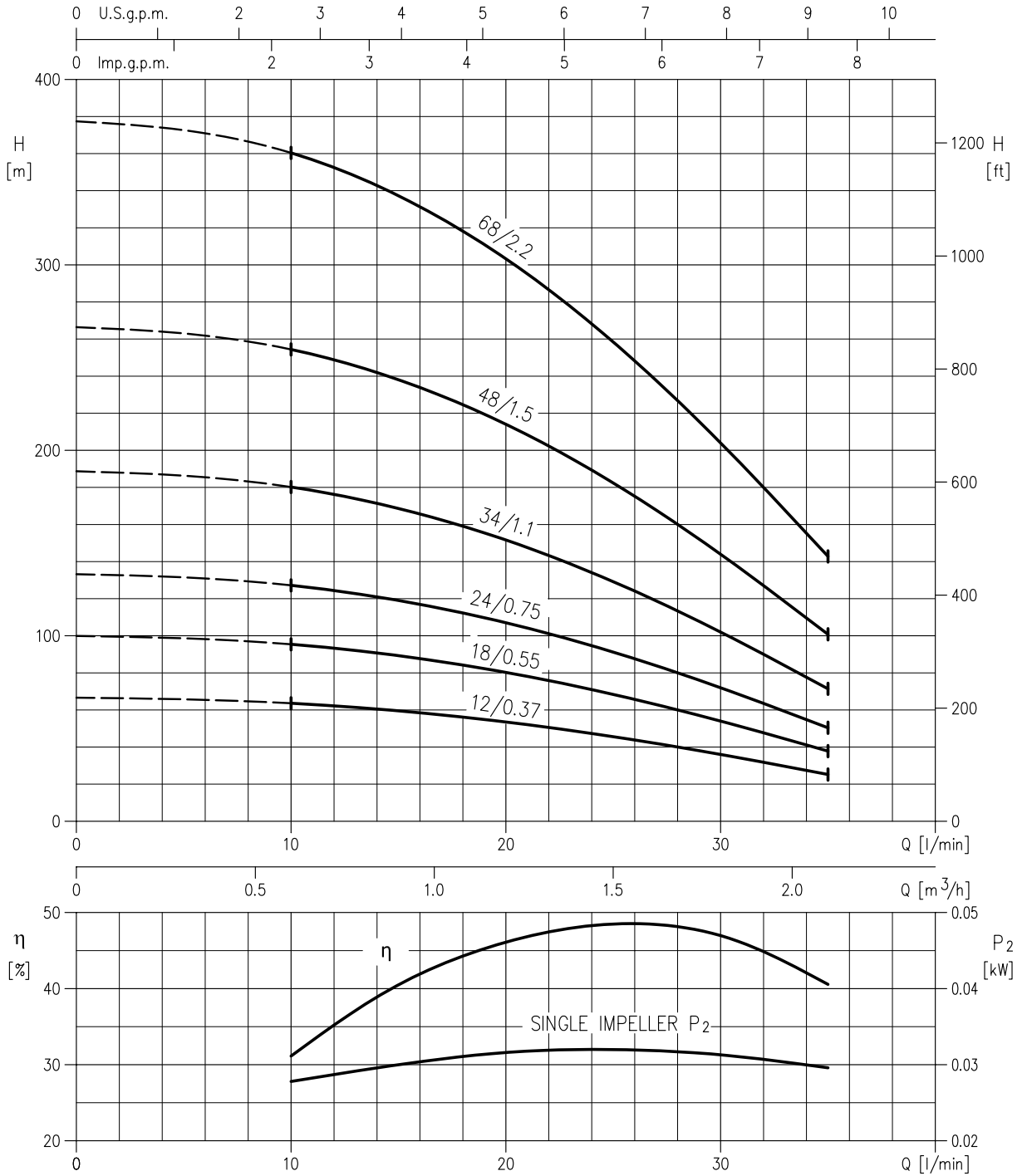

Rotation speed $\approx 2850 \text{ min}^{-1}$
 Test standard: ISO 9906-Annex A

WINNER 4N2 - MEI > 0.70 - Impeller diameter = 76 mm

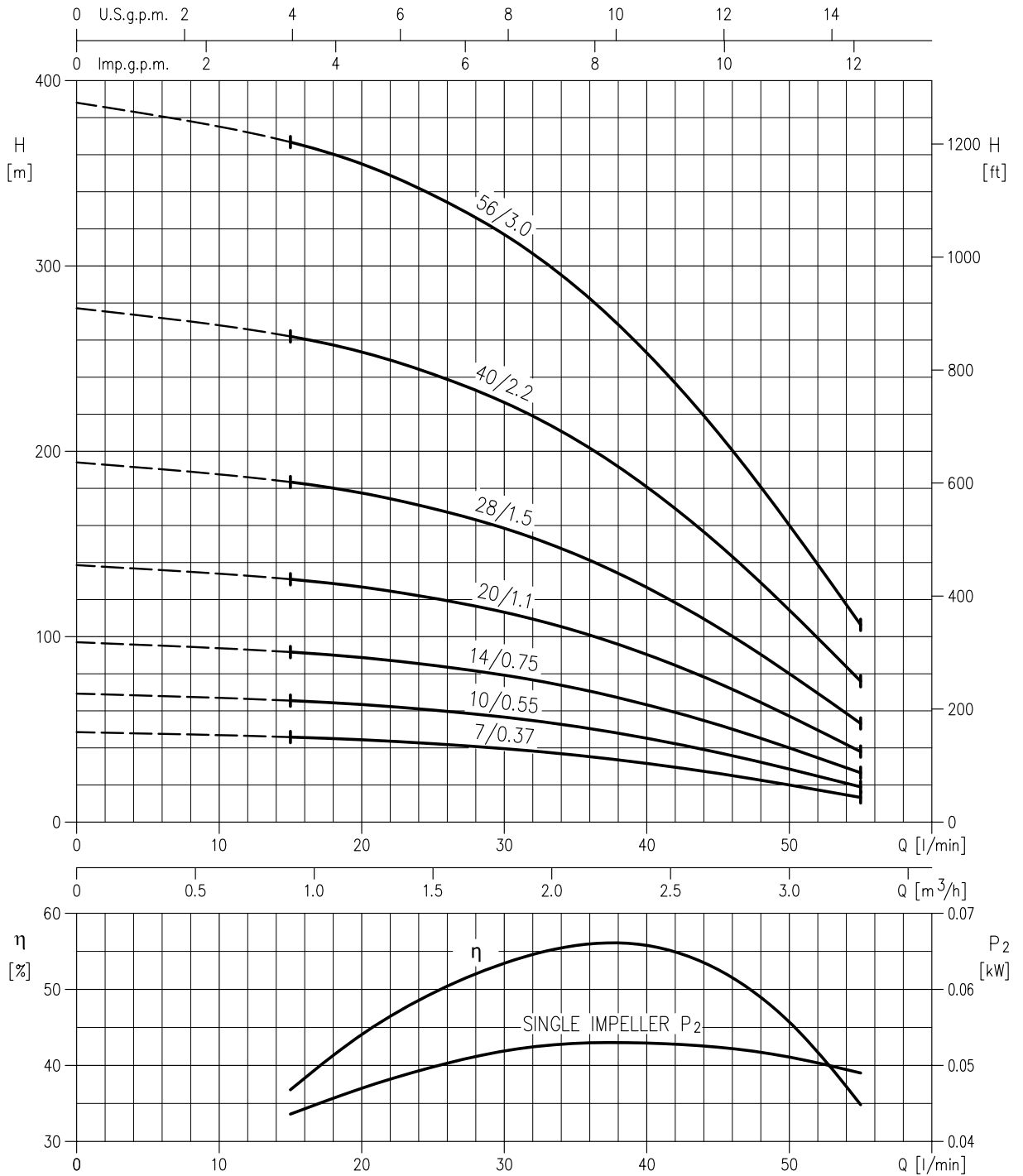

Rotation speed $\approx 2850 \text{ min}^{-1}$
 Test standard: ISO 9906-Annex A

WINNER 4N4 - MEI > 0.70 - Impeller diameter = 76 mm

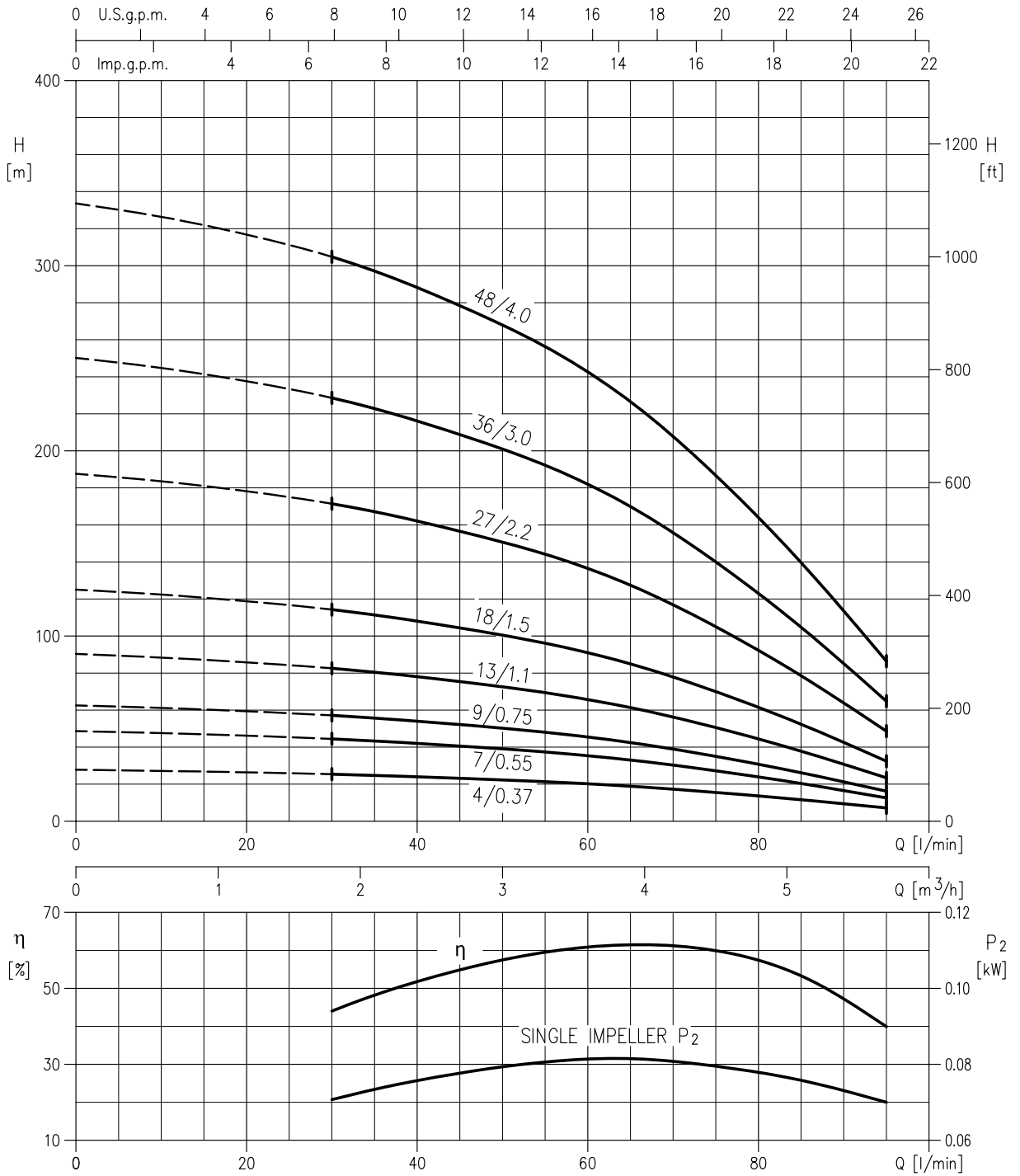

Rotation speed $\approx 2850 \text{ min}^{-1}$
 Test standard: ISO 9906-Annex A

WINNER 4N7 - MEI > 0.40 - Impeller diameter = 74.2 mm

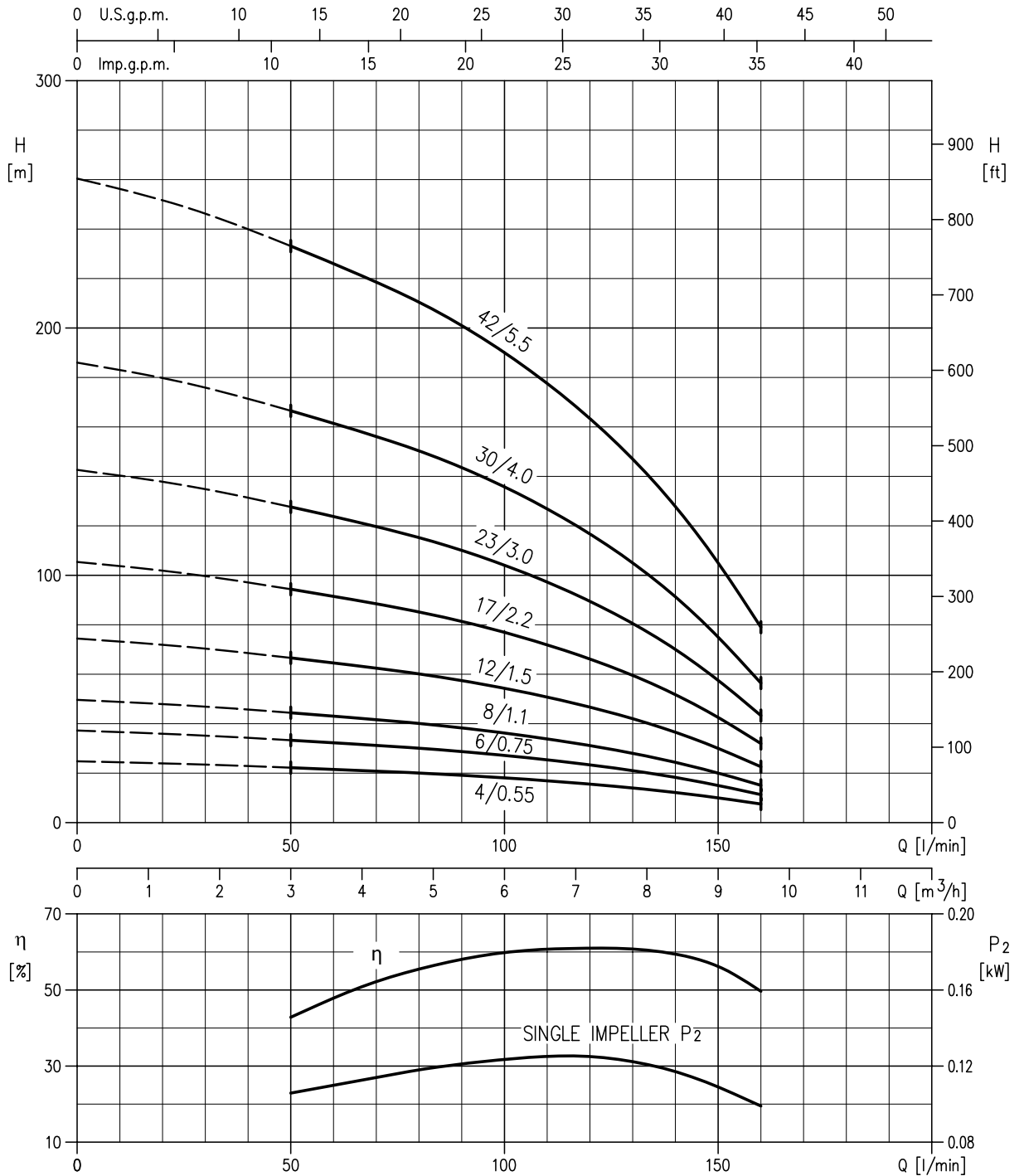

Rotation speed ≈ 2850 min⁻¹
 Test standard: ISO 9906-Annex A

WINNER 4N10 - MEI > 0.40 - Impeller diameter = 76.4 mm

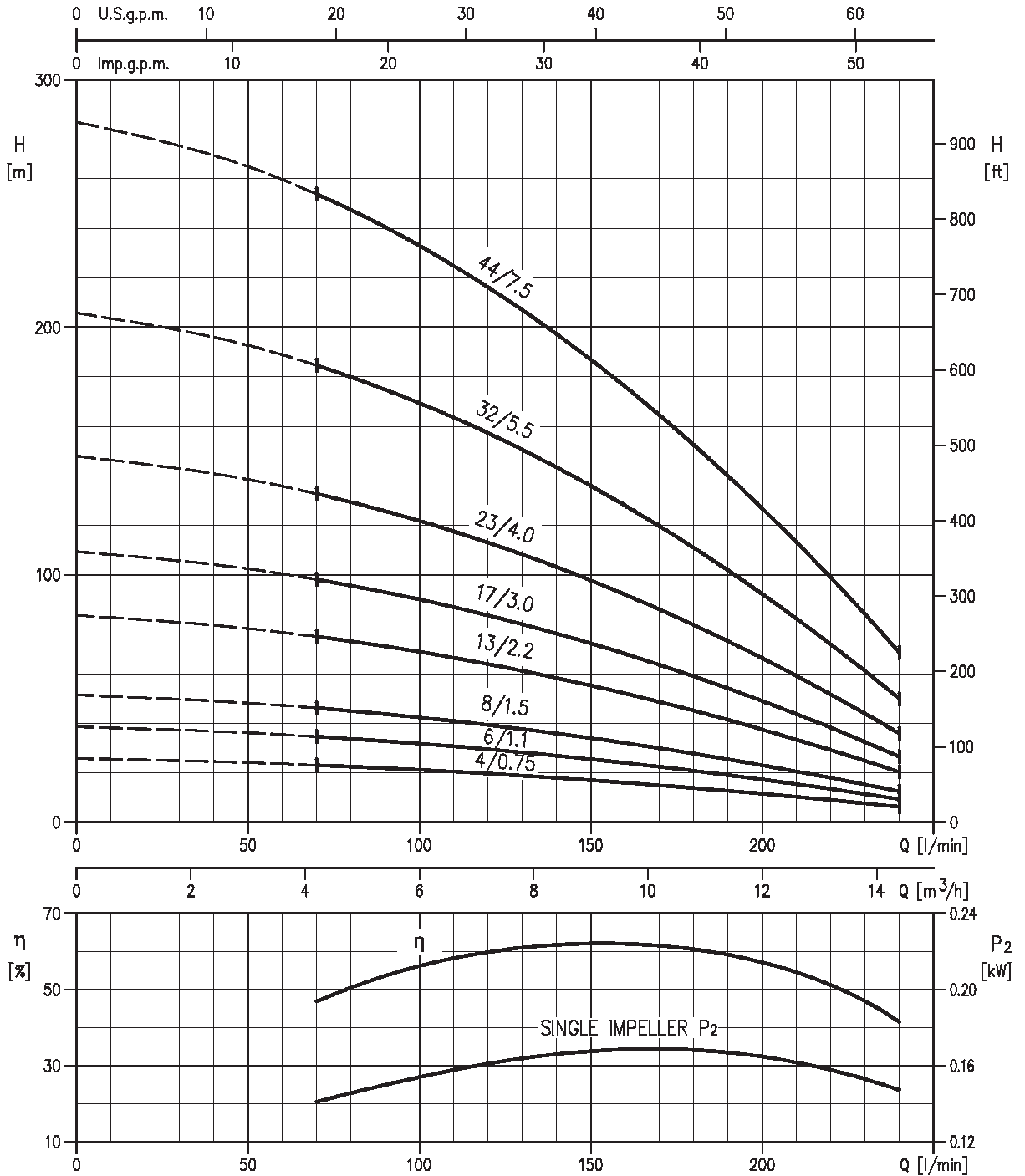

Rotation speed ≈ 2850 min⁻¹
 Test standard: ISO 9906-Annex A

WINNER 4N15 - MEI > 0.40 - Impeller diameter = 78 mm

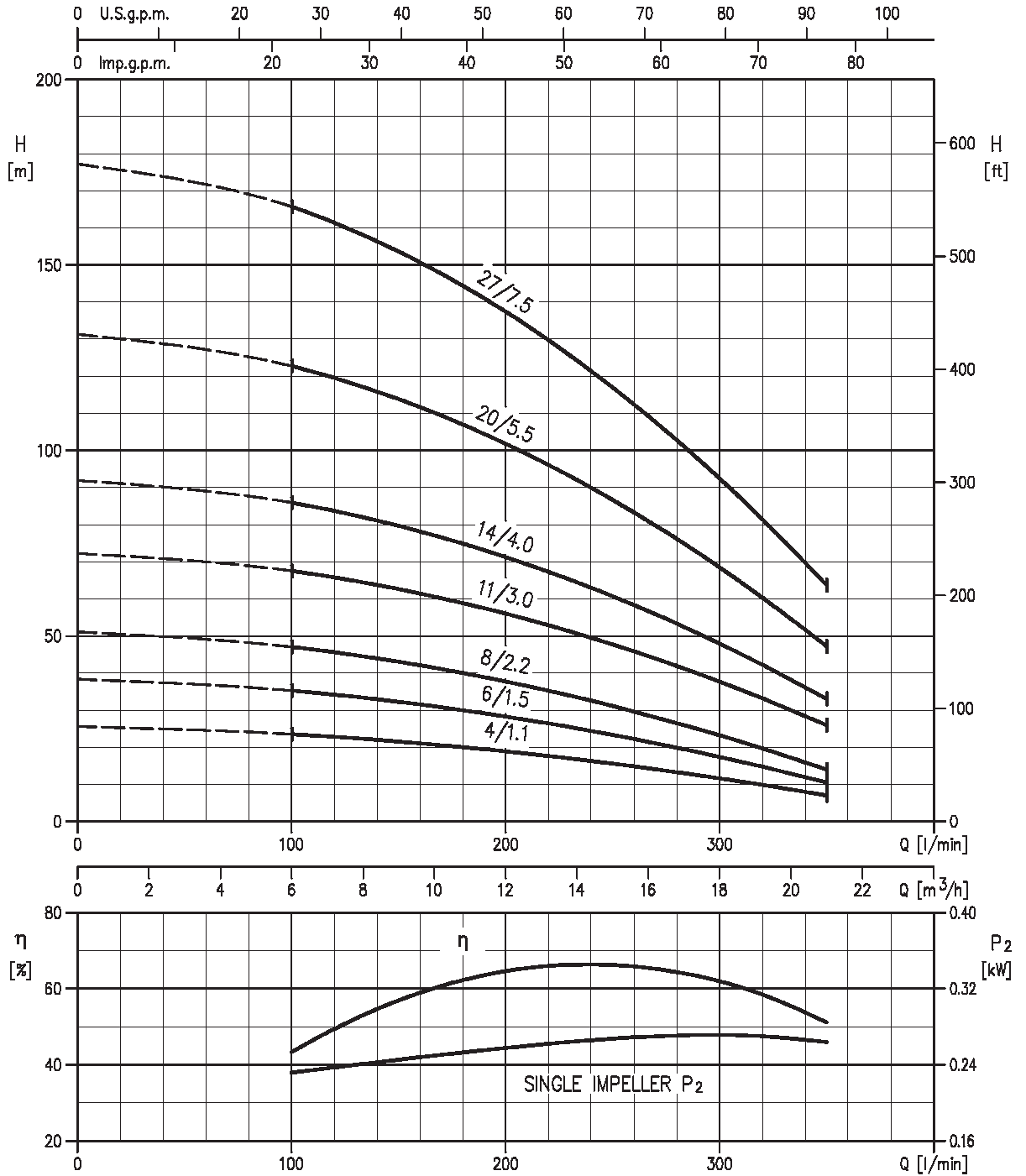

Rotation speed ≈ 2850 min⁻¹
 Test standard: ISO 9906-Annex A

**SECTIONAL VIEW
4N1 - 4N2 - 4N4**

SINGLE PUMP CASING

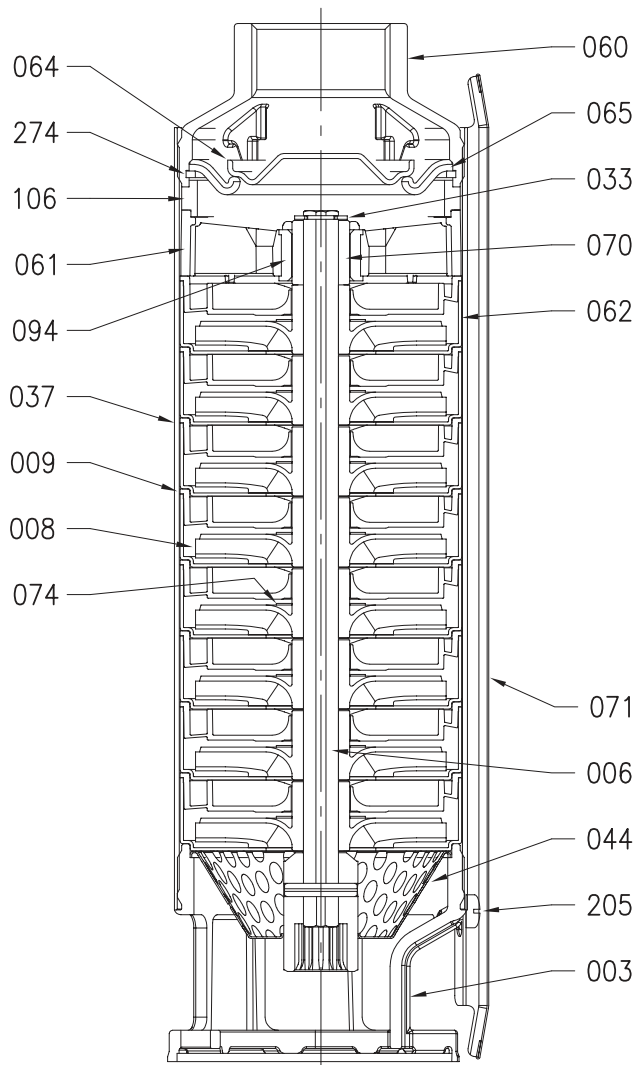

DOUBLE PUMP CASING

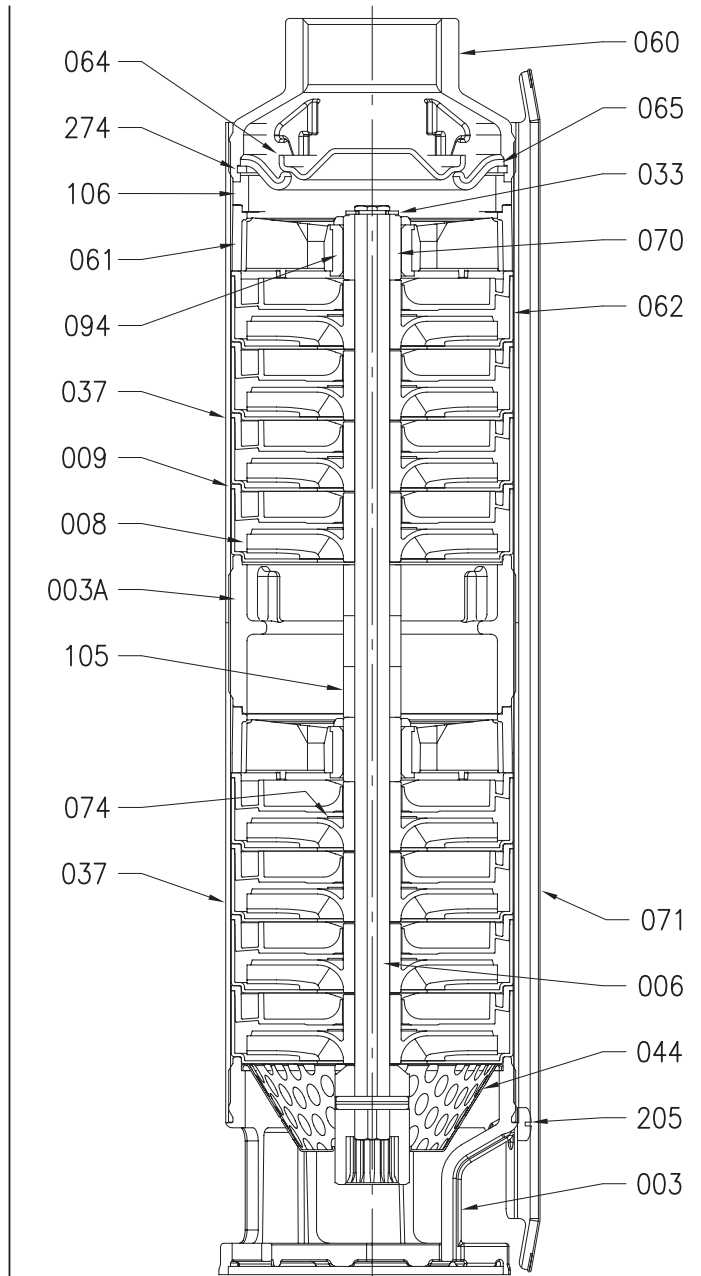

SECTIONAL VIEW
4N7

SINGLE PUMP CASING

DOUBLE PUMP CASING

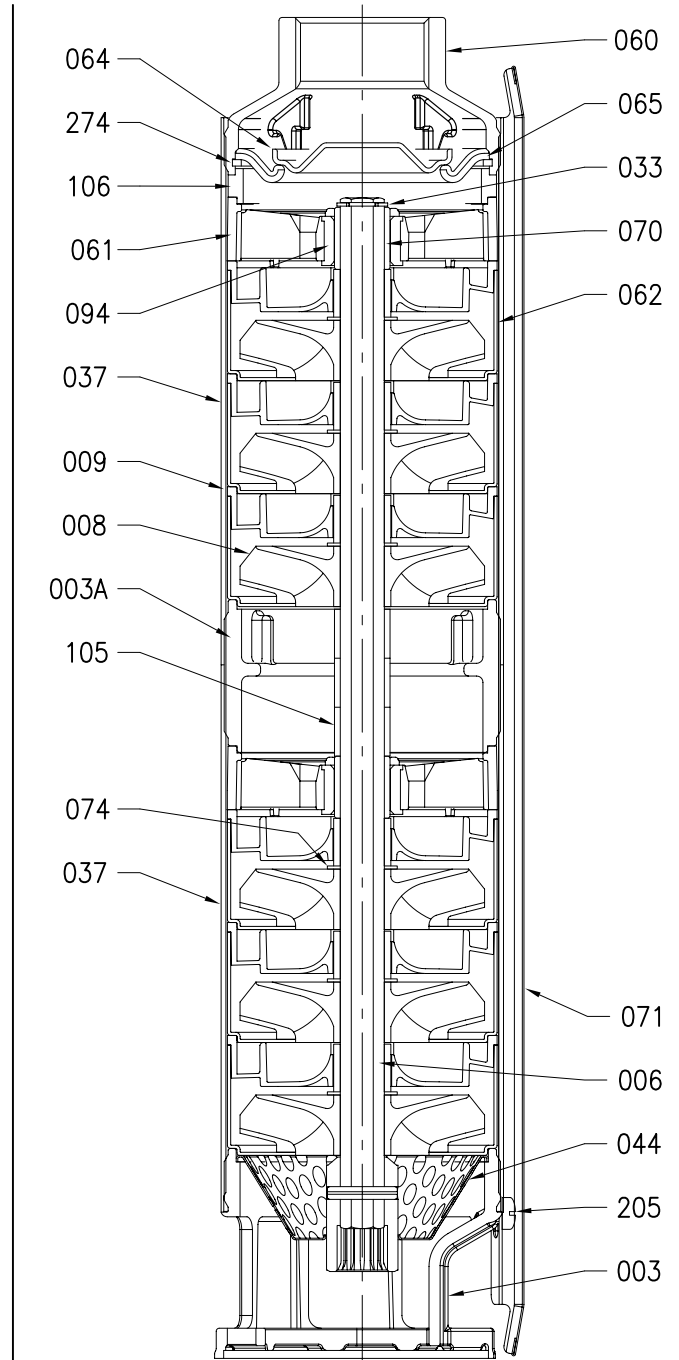
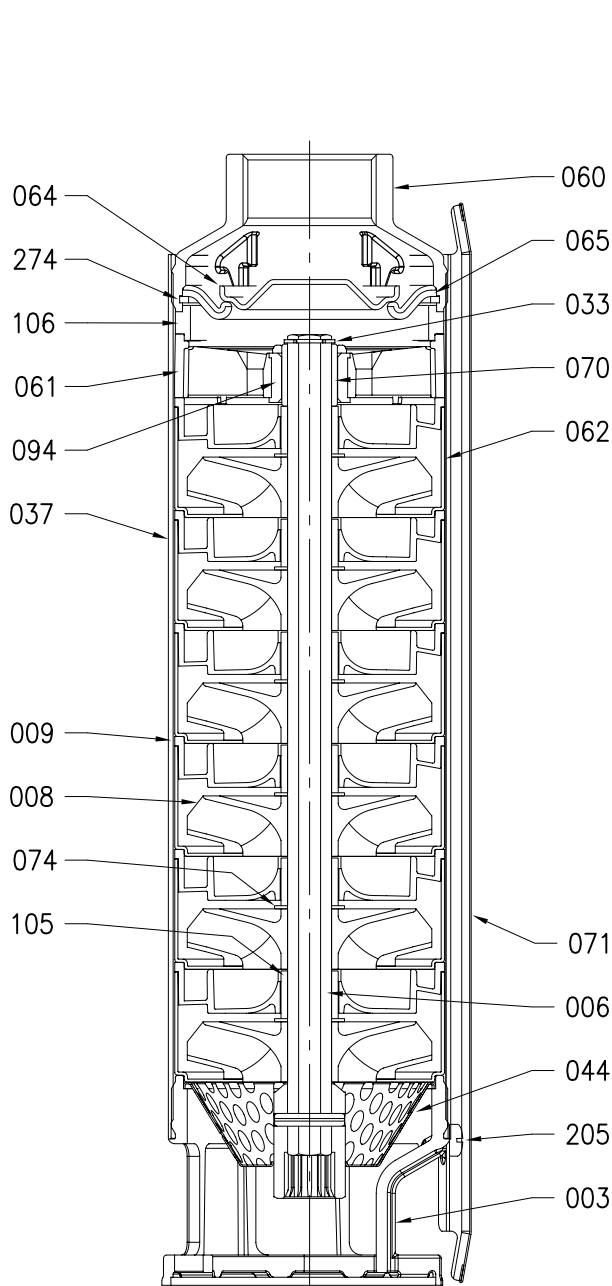

SECTIONAL VIEW
4N10

SINGLE PUMP CASING

DOUBLE PUMP CASING

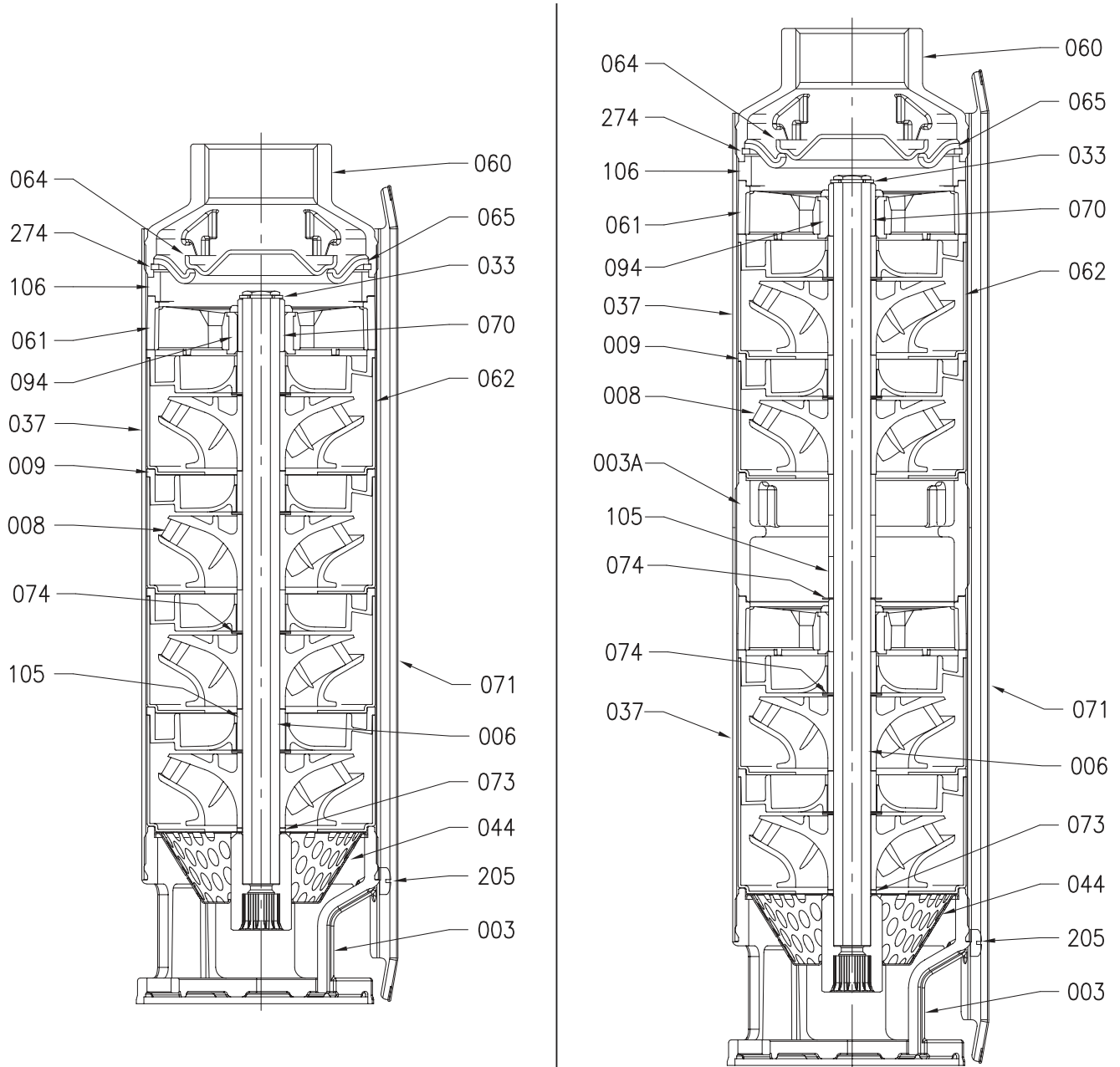

**SECTIONAL VIEW
4N15**

SINGLE PUMP CASING

DOUBLE PUMP CASING

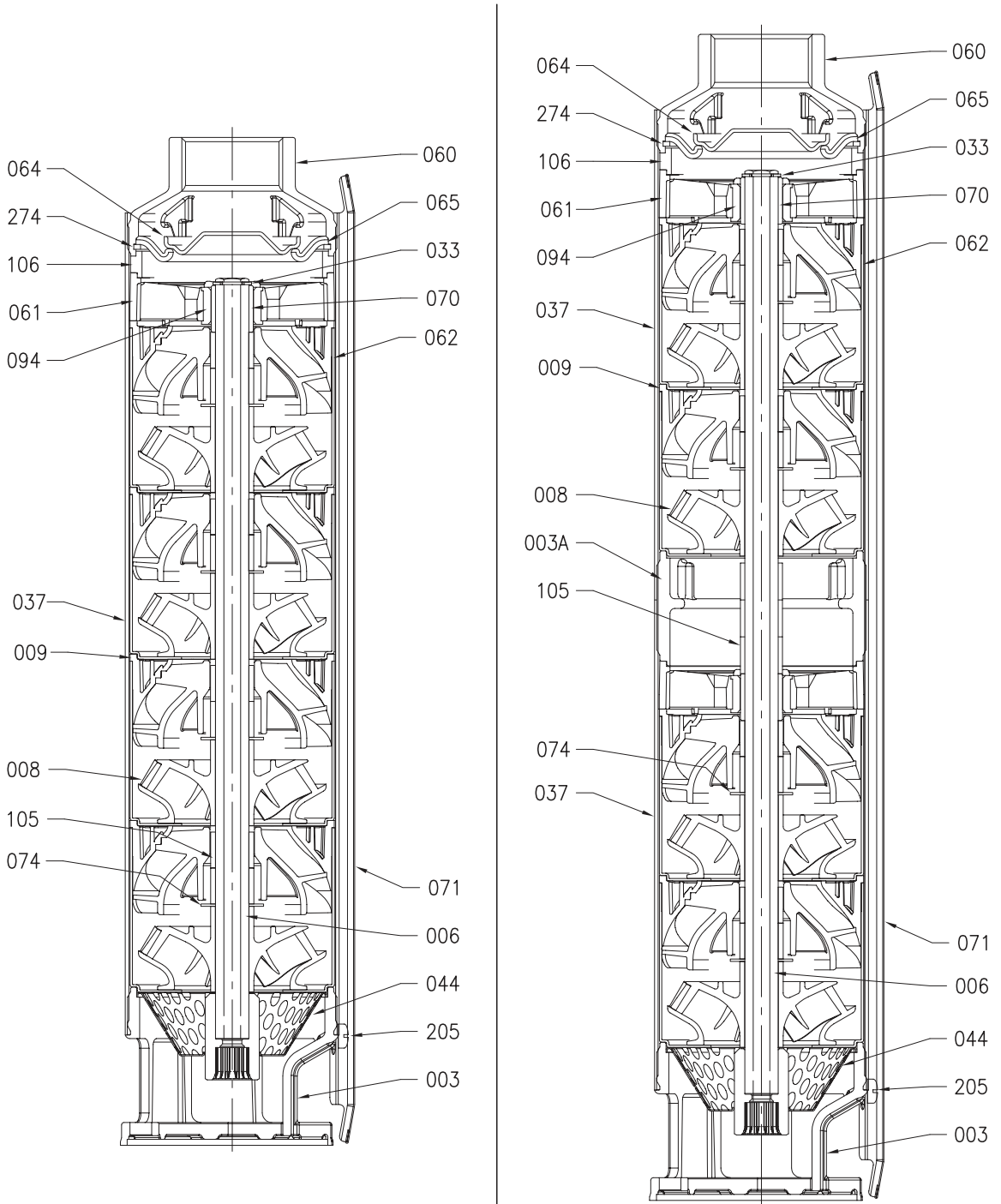

SECTIONAL VIEW TABLE

N°	PART.NAME	MATERIAL	Q.TY
003	Bracket	EN 1.4308 (ASTM CF8)	1
003A	Join ring	EN 1.4308 (ASTM CF8)	[*]
006	Pump shaft with coupling	EN 1.4301 (AISI 304)	1
008	Impeller	Ixef® (model 4N1, 4N2, 4N4, 4N7)	[*]
		Glass fibre reinforced PC (model 4N10, 4N15)	[*]
009	Diffuser	PPE+PS Glass fibre reinforced	[*]
033	Elastic Ring	EN 1.4301 (AISI 304)	1
037	Outer casing	EN 1.4301 (AISI 304)	[*]
044	Strainer	EN 1.4301 (AISI 304)	1
060	Discharge casing	EN 1.4308 (ASTM CF8)	1
061	Upper / Intermediate bracket	PPE+PS Glass fibre reinforced	[*]
062	Stage housing	EN 1.4301 (AISI 304)	[*]
064	Valve	EN 1.4301 (AISI 304)	1
065	Valve seat	EN 1.4301 (AISI 304) + EPDM Rubber	1
070	Shaft sleeve bearing	Alumina (Ceramic)	[*]
071	Cable guard	EN 1.4301 (AISI 304)	1
073	Thrust washer first impeller	EN 1.4301 (AISI 304)	[*]
074	Thrust washer	EN 1.4301 (AISI 304)	[*]
094	Bearing	EPDM Rubber	[*]
105	Spacer	PPE+PS Glass fibre reinforced	[*]
106	Spacer	NORYL+GF20%	1
205	Screw (M4 x 6 UNI 7687)	EN 1.4301 (AISI 304)	2
274	Elastic Ring	EN 1.4310 (AISI 302)	1

[*] See table pag.305

QUANTITY FOR MODEL

Pump type	Quantity for model										
	N°003A	N°008	N°009	N°037	N°061	N°062	N°070	N°073	N°074	N°094	N°105
4N1- 12 [*]	-	12	12	1	1	12	1	-	12	1	-
4N1- 18 [*]	-	18	18	1	1	18	1	-	18	1	-
4N1- 24 [*]	-	24	24	1	1	24	1	-	24	1	-
4N1- 34 [*]	-	34	34	1	1	34	1	-	34	1	-
4N1- 48 [**]	1	48	48	2	2	48	2	-	48	2	1
4N1- 68 [**]	1	68	68	2	2	68	2	-	68	2	1
4N2- 7 [*]	-	7	7	1	1	7	1	-	7	1	-
4N2- 10 [*]	-	10	10	1	1	10	1	-	10	1	-
4N2- 14 [*]	-	14	14	1	1	14	1	-	14	1	-
4N2- 20 [*]	-	20	20	1	1	20	1	-	20	1	-
4N2- 28 [*]	-	28	28	1	1	28	1	-	28	1	-
4N2- 40 [**]	1	40	40	2	2	40	2	-	40	2	1
4N2- 56 [**]	1	56	56	2	2	56	2	-	56	2	1
4N4- 4 [*]	-	4	4	1	1	4	1	-	4	1	-
4N4- 7 [*]	-	7	7	1	1	7	1	-	7	1	-
4N4- 9 [*]	-	9	9	1	1	9	1	-	9	1	-
4N4- 13 [*]	-	13	13	1	1	13	1	-	13	1	-
4N4- 18 [*]	-	18	18	1	1	18	1	-	18	1	-
4N4- 27 [*]	-	27	27	1	1	27	1	-	27	1	-
4N4- 36 [**]	1	36	36	2	2	36	2	-	36	2	1
4N4- 48 [**]	1	48	48	2	2	48	2	-	48	2	1
4N7- 4 [*]	-	4	4	1	1	4	1	-	4	1	4
4N7- 6 [*]	-	6	6	1	1	6	1	-	6	1	6
4N7- 8 [*]	-	8	8	1	1	8	1	-	8	1	8
4N7- 12 [*]	-	12	12	1	1	12	1	-	12	1	12
4N7- 17 [*]	-	17	17	1	1	17	1	-	17	1	17
4N7- 23 [*]	-	23	23	1	1	23	1	-	23	1	23
4N7- 30 [**]	1	30	30	2	2	30	2	-	30	2	33
4N7- 42 [**]	1	42	42	2	2	42	2	-	42	2	45
4N10- 4 [*]	-	4	4	1	1	4	1	1	8	1	4
4N10- 6 [*]	-	6	6	1	1	6	1	1	12	1	6
4N10- 8 [*]	-	8	8	1	1	8	1	1	16	1	8
4N10- 13 [*]	-	13	13	1	1	13	1	1	28	1	13
4N10- 17 [*]	-	17	17	1	1	17	1	1	34	1	17
4N10- 23 [*]	-	23	23	1	1	23	1	1	46	1	23
4N10- 32 [**]	1	32	32	2	2	32	2	1	65	2	37
4N10- 44 [**]	1	44	44	2	2	44	2	1	89	2	51
4N15- 4 [*]	-	4	4	1	1	4	1	-	4	1	8
4N15- 6 [*]	-	6	6	1	1	6	1	-	6	1	12
4N15- 8 [*]	-	8	8	1	1	8	1	-	8	1	16
4N15- 11 [*]	-	11	11	1	1	11	1	-	11	1	22
4N15- 14 [*]	-	14	14	1	1	14	1	-	14	1	28
4N15- 20 [*]	1	20	20	2	2	20	2	-	20	2	40
4N15- 27 [**]	1	27	27	2	2	27	2	-	27	2	54

[*] See drawing pag. 300 - 303 Single pump casing

[**] See drawing pag. 300 - 303 Double pump casing

PUMP DRAWING

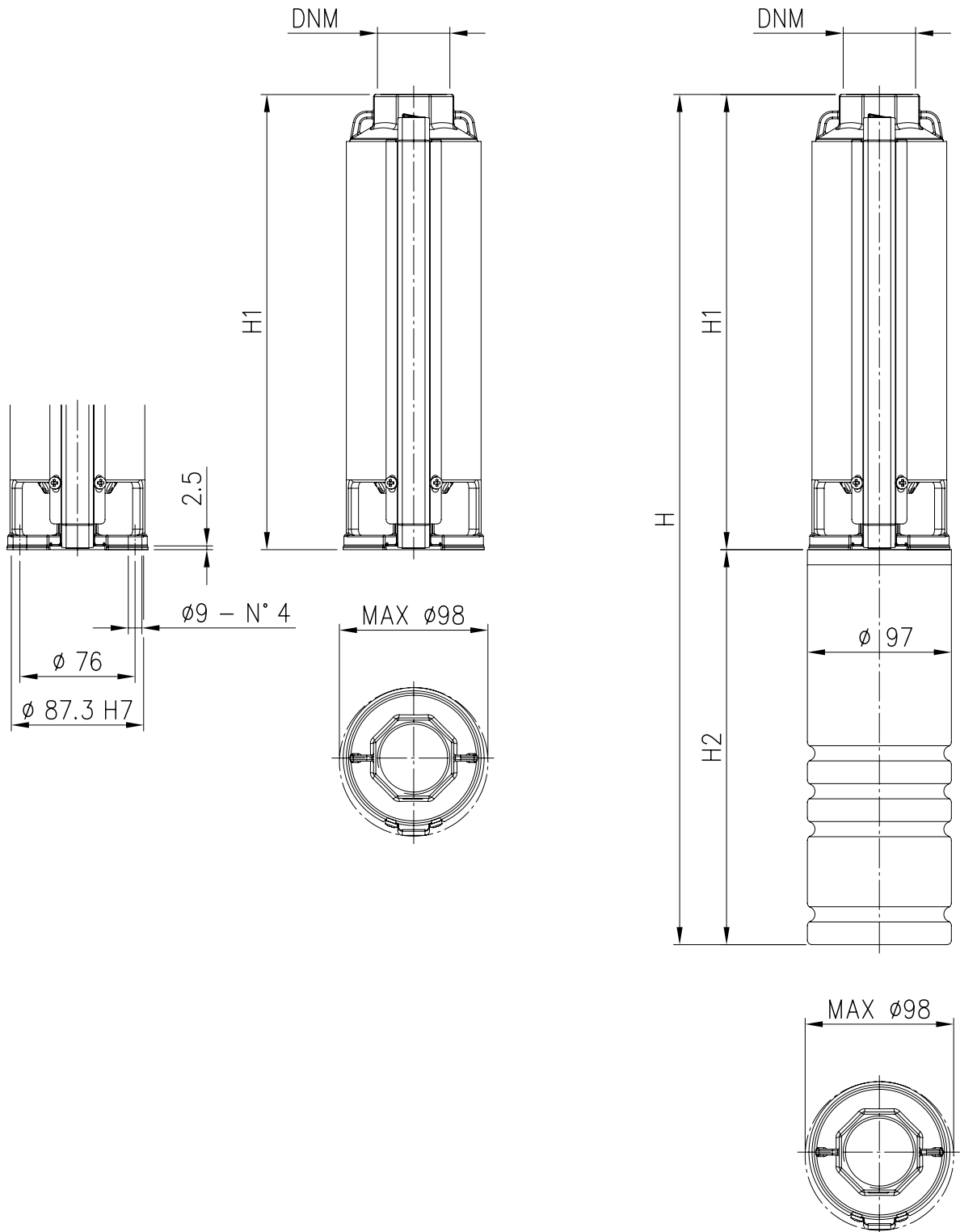

DIMENSIONS PUMP TABLE

Pump type	Power		Pump without motor		Pump with oil filled motor				Pump with water filled motor			
	[kW]	[HP]	H1 [mm]	DNM	single phase		three phase		single phase		three phase	
					H2 [mm]	H [mm]	H2 [mm]	H [mm]	H2 [mm]	H [mm]	H2 [mm]	H [mm]
4N1- 12	0.37	0.5	353	G 1 1/4	325	678	304	657	228	581	214	567
4N1- 18	0.55	0.75	458	G 1 1/4	325	783	325	783	253	711	228	686
4N1- 24	0.75	1	563	G 1 1/4	350	913	325	888	283	846	248	811
4N1- 34	1.1	1.5	738	G 1 1/4	385	1123	350	1088	307	1045	283	1021
4N1- 48	1.5	2	1049	G 1 1/4	420	1469	385	1434	339	1388	307	1356
4N1- 68	2.2	3	1399	G 1 1/4	470	1869	420	1819	437	1836	339	1738
4N2- 7	0.37	0.5	265	G 1 1/4	325	590	304	569	228	493	214	479
4N2- 10	0.55	0.75	318	G 1 1/4	325	643	325	643	253	571	228	546
4N2- 14	0.75	1	388	G 1 1/4	350	738	325	713	283	671	248	636
4N2- 20	1.1	1.5	493	G 1 1/4	385	878	350	843	307	800	283	776
4N2- 28	1.5	2	633	G 1 1/4	420	1053	385	1018	339	972	307	940
4N2- 40	2.2	3	909	G 1 1/4	470	1379	420	1329	437	1346	339	1248
4N2- 56	3	4	1189	G 1 1/4	-	-	544	1733	-	-	394	1583
4N4- 4	0.37	0.5	229	G 1 1/4	325	554	304	533	228	457	214	443
4N4- 7	0.55	0.75	293	G 1 1/4	325	618	325	618	253	546	228	521
4N4- 9	0.75	1	336	G 1 1/4	350	686	325	661	283	619	248	584
4N4- 13	1.1	1.5	422	G 1 1/4	385	807	350	772	307	729	283	705
4N4- 18	1.5	2	530	G 1 1/4	420	950	385	915	339	869	307	837
4N4- 27	2.2	3	723	G 1 1/4	470	1193	420	1143	437	1160	339	1062
4N4- 36	3	4	983	G 1 1/4	-	-	544	1527	-	-	394	1377
4N4- 48	4	5.5	1241	G 1 1/4	-	-	574	1815	-	-	543	1784
4N7- 4	0.55	0.75	285	G 2	325	610	325	610	253	538	228	513
4N7- 6	0.75	1	356	G 2	350	706	325	681	283	639	248	604
4N7- 8	1.1	1.5	427	G 2	385	812	350	777	307	734	283	710
4N7- 12	1.5	2	569	G 2	420	989	385	954	339	908	307	876
4N7- 17	2.2	3	746	G 2	470	1216	420	1166	437	1183	339	1085
4N7- 23	3	4	959	G 2	-	-	544	1503	-	-	477	1436
4N7- 30	4	5.5	1274	G 2	-	-	574	1848	-	-	543	1817
4N7- 42	5.5	7.5	1700	G 2	-	-	644	2344	-	-	653	2353
4N10- 4	0.75	1	325	G 2	350	675	325	650	283	608	248	573
4N10- 6	1.1	1.5	412	G 2	385	797	350	762	307	719	283	695
4N10- 8	1.5	2	500	G 2	420	920	385	885	339	839	307	807
4N10- 13	2.2	3	722	G 2	470	1192	420	1142	437	1159	339	1060
4N10- 17	3	4	900	G 2	-	-	544	1444	-	-	477	1377
4N10- 23	4	5.5	1165	G 2	-	-	574	1739	-	-	543	1708
4N10- 32	5.5	7.5	1675	G 2	-	-	644	2319	-	-	653	2328
4N10- 44	7.5	10	2250	G 2	-	-	805	3055	-	-	731	2981
4N15- 4	1.1	1.5	425	G 2	385	810	350	775	307	732	283	708
4N15- 6	1.5	2	562	G 2	420	982	385	947	339	901	307	869
4N15- 8	2.2	3	702	G 2	470	1172	420	1122	437	1139	339	1041
4N15- 11	3	4	908	G 2	-	-	544	1452	-	-	477	1385
4N15- 14	4	5.5	1120	G 2	-	-	574	1694	-	-	543	1663
4N15- 20	5.5	7.5	1600	G 2	-	-	644	2244	-	-	653	2253
4N15- 27	7.5	10	2158	G 2	-	-	805	2963	-	-	731	2889

PACKING

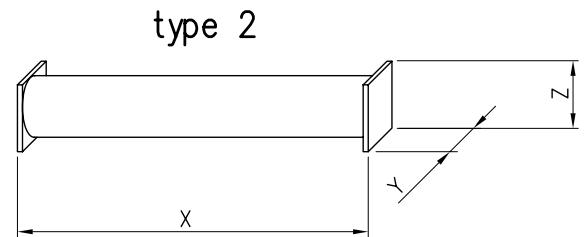
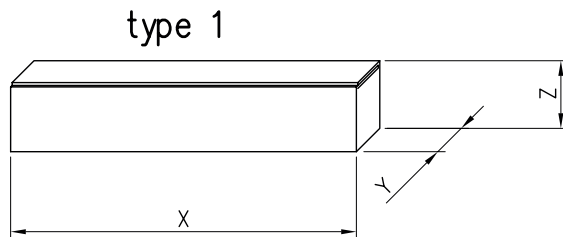

Pump type	Pump with oil filled motor										Pump with water filled motor														
	single phase					three phase					single phase					three phase									
	X [mm]	Y [mm]	Z [mm]	Weight [Kgf]	type	X [mm]	Y [mm]	Z [mm]	Weight [Kgf]	type	X [mm]	Y [mm]	Z [mm]	Weight [Kgf]	type	X [mm]	Y [mm]	Z [mm]	Weight [Kgf]	type					
4N1- 12	495	100	100	3.7	1	800	100	100	10.7	1	800	100	100	10.2	1	640	100	100	11.7	1	640	100	100	10.9	1
4N1- 18	495	100	100	4.8	1	800	100	100	12.4	1	800	100	100	11.8	1	800	100	100	14.0	1	800	100	100	12.5	1
4N1- 24	640	100	100	5.9	1	1035	100	100	14.6	1	1035	100	100	13.5	1	1035	100	100	16.3	1	1035	100	100	14.6	1
4N1- 34	800	100	100	8.0	1	1300	100	100	18.3	1	1300	100	100	16.7	1	1300	100	100	19.8	1	1035	100	100	18.2	1
4N1- 48	1300	100	100	11.8	1	1530	100	100	23.8	1	1530	100	100	22.2	1	1530	100	100	24.7	1	1530	100	100	23.0	1
4N1- 68	1530	100	100	15.0	1	1986	110	110	29.2	2	1986	110	110	27.0	2	1986	110	110	32.3	2	1846	110	110	27.6	2
4N2- 7	350	100	100	3.8	1	640	100	100	10.8	1	640	100	100	10.3	1	495	100	100	12.8	1	495	100	100	12.2	1
4N2- 10	350	100	100	4.1	1	800	100	100	11.7	1	800	100	100	11.1	1	640	100	100	14.1	1	640	100	100	13.0	1
4N2- 14	495	100	100	4.4	1	800	100	100	13.1	1	800	100	100	12.0	1	800	100	100	14.8	1	640	100	100	13.1	1
4N2- 20	495	100	100	5.3	1	1035	100	100	15.6	1	1035	100	100	14.0	1	1035	100	100	17.1	1	800	100	100	15.5	1
4N2- 28	640	100	100	6.7	1	1300	100	100	18.7	1	1035	100	100	17.1	1	1035	100	100	19.6	1	1035	100	100	17.9	1
4N2- 40	1035	100	100	10.0	1	1530	100	100	24.2	1	1530	100	100	22.0	1	1530	100	100	27.3	1	1300	100	100	22.6	1
4N2- 56	1300	100	100	13.0	1	-	-	-	-	-	1846	110	110	25.8	2	-	-	-	-	-	1846	110	110	28.0	2
4N4- 4	350	100	100	2.4	1	640	100	100	9.4	1	640	100	100	8.9	1	495	100	100	10.4	1	495	100	100	9.6	1
4N4- 7	350	100	100	3.0	1	640	100	100	10.6	1	640	100	100	10.0	1	640	100	100	12.2	1	640	100	100	10.7	1
4N4- 9	350	100	100	3.4	1	800	100	100	12.1	1	800	100	100	11.0	1	640	100	100	13.8	1	640	100	100	12.1	1
4N4- 13	495	100	100	4.3	1	1035	100	100	14.6	1	800	100	100	13.0	1	800	100	100	16.1	1	800	100	100	14.5	1
4N4- 18	640	100	100	5.4	1	1035	100	100	17.4	1	1035	100	100	15.8	1	1035	100	100	18.3	1	1035	100	100	16.6	1
4N4- 27	800	100	100	7.3	1	1300	100	100	21.5	1	1300	100	100	19.3	1	1300	100	100	24.6	1	1300	100	100	19.9	1
4N4- 36	1035	100	100	11.0	1	-	-	-	-	-	1530	100	100	23.8	1	-	-	-	-	-	1530	100	100	26.0	1
4N4- 48	1300	100	100	14.0	1	-	-	-	-	-	1986	110	110	29.3	2	-	-	-	-	-	1986	110	110	34.0	2
4N7- 4	350	100	100	3.0	1	640	100	100	10.6	1	640	100	100	10.0	1	640	100	100	12.2	1	640	100	100	10.7	1
4N7- 6	495	100	100	3.5	1	800	100	100	12.2	1	800	100	100	11.1	1	800	100	100	13.9	1	640	100	100	12.2	1
4N7- 8	495	100	100	4.0	1	1035	100	100	14.3	1	800	100	100	12.7	1	800	100	100	15.8	1	800	100	100	14.2	1
4N7- 12	640	100	100	5.5	1	1035	100	100	17.5	1	1035	100	100	15.9	1	1035	100	100	18.4	1	1035	100	100	16.7	1
4N7- 17	800	100	100	7.1	1	1300	100	100	21.3	1	1300	100	100	19.1	1	1300	100	100	24.4	1	1300	100	100	19.7	1
4N7- 23	1035	100	100	9.0	1	-	-	-	-	-	1530	100	100	21.8	1	-	-	-	-	-	1530	100	100	24.0	1
4N7- 30	1300	100	100	12.8	1	-	-	-	-	-	2466	110	110	28.1	2	-	-	-	-	-	2466	110	110	32.8	2
4N7- 42	1846	110	110	16.5	2	-	-	-	-	-	3036	110	110	35.1	2	-	-	-	-	-	3036	110	110	43.1	2
4N10- 4	350	100	100	3.3	1	800	100	100	12.0	1	800	100	100	10.9	1	640	100	100	13.7	1	640	100	100	12.0	1
4N10- 6	495	100	100	4.1	1	1035	100	100	14.4	1	800	100	100	12.8	1	800	100	100	15.9	1	800	100	100	14.3	1
4N10- 8	640	100	100	5.0	1	1035	100	100	17.0	1	1035	100	100	15.4	1	1035	100	100	17.9	1	1035	100	100	16.2	1
4N10- 13	800	100	100	7.3	1	1300	100	100	21.5	1	1300	100	100	19.3	1	1300	100	100	24.6	1	1300	100	100	19.9	1
4N10- 17	1035	100	100	9.1	1	-	-	-	-	-	1530	100	100	21.9	1	-	-	-	-	-	1530	100	100	24.1	1
4N10- 23	1300	100	100	11.7	1	-	-	-	-	-	1846	110	110	27.0	2	-	-	-	-	-	1846	110	110	31.7	2
4N10- 32	1846	110	110	17.0	2	-	-	-	-	-	2466	110	110	35.6	2	-	-	-	-	-	2466	110	110	43.6	2
4N10- 44	2466	110	110	22.7	2	-	-	-	-	-	3036	110	110	49.7	2	-	-	-	-	-	3036	110	110	53.3	2
4N15- 4	495	100	100	3.8	1	1035	100	100	14.1	1	800	100	100	12.5	1	800	100	100	15.6	1	800	100	100	14.0	1
4N15- 6	640	100	100	5.0	1	1035	100	100	17.0	1	1035	100	100	15.4	1	1035	100	100	17.9	1	1035	100	100	16.2	1
4N15- 8	800	100	100	6.0	1	1300	100	100	20.2	1	1300	100	100	18.0	1	1300	100	100	23.3	1	1300	100	100	18.6	1
4N15- 11	1035	100	100	8.2	1	-	-	-	-	-	1530	100	100	21.0	1	-	-	-	-	-	1530	100	100	23.2	1
4N15- 14	1300	100	100	10.5	1	-	-	-	-	-	1846	110	110	25.8	2	-	-	-	-	-	1846	110	110	30.5	2
4N15- 20	1846	110	110	15.5	2	-	-	-	-	-	2466	110	110	34.1	2	-	-	-	-	-	2466	110	110	42.1	2
4N15- 27	2466	110	110	23.0	2	-	-	-	-	-	3036	110	110	50.0	2	-	-	-	-	-	3036	110	110	53.6	2

OIL FILLED MOTOR

Power		Hight thrust [N]	Single phase 230 V				Three phase 380 V				Three phase 415 V			
[kW]	[HP]		Input [kW]	IN [A]	IA [A]	Power factor	Input [kW]	IN [A]	IA [A]	Power factor	Input [kW]	IN [A]	IA [A]	Power factor
0,37	0,5	1500	0,78	3,6	10,2	0,94	0,66	1,4	5,0	0,72	0,83	1,6	5,0	0,72
0,55	0,75	1500	0,97	4,5	13,6	0,94	0,94	1,9	7,0	0,75	1,08	2,0	7,0	0,75
0,75	1	1500	1,32	6,0	18,5	0,96	1,17	2,4	10,0	0,74	1,38	2,6	10,0	0,74
1,1	1,5	1500	1,83	8,2	26,0	0,97	1,56	3,2	14,0	0,74	1,81	3,4	14,0	0,74
1,5	2	1500	2,48	11,0	34,0	0,98	2,09	4,4	17,0	0,72	2,38	4,6	17,0	0,72
2,2	3	4400	3,27	14,8	48,0	0,96	-	-	-	-	-	-	-	-
2,2	3	1500	-	-	-	-	3,00	6	24,0	0,76	3,39	6,2	24,0	0,76
2,2	3	5000	-	-	-	-	3,02	5,6	23,0	0,82	3,42	5,8	23,0	0,82
3	4	5000	-	-	-	-	4,05	7,7	30,0	0,80	4,49	7,8	30,0	0,80
4	5,5	5000	-	-	-	-	5,24	9,7	45,0	0,82	5,78	9,8	45,0	0,82
5,5	7,5	5000	-	-	-	-	7,37	13,5	55,0	0,83	8,23	13,8	55,0	0,83
7,5	10	4400	-	-	-	-	9,75	19	72,0	0,78	10,93	19,5	72,0	0,78

WATER FILLED MOTOR

Power		Hight thrust [N]	Single phase 230 V				Three phase 380 V				Three phase 415 V			
[kW]	[HP]		Input [kW]	IN [A]	IA [A]	Power factor	Input [kW]	IN [A]	IA [A]	Power factor	Input [kW]	IN [A]	IA [A]	Power factor
0,37	0,5	3000	0,69	3,3	12,6	0,91	0,57	1,1	5,1	0,79	0,58	1,14	5,61	0,71
0,55	0,75	3000	0,93	4,3	17,7	0,94	0,83	1,6	7	0,79	0,86	1,7	7,7	0,7
0,75	1	3000	1,28	5,7	22,7	0,98	1,07	2,0	10,1	0,81	1,10	2,1	10,9	0,73
1,1	1,5	3000	1,78	8,4	33,9	0,92	1,51	2,8	15,3	0,82	1,54	2,9	16,7	0,74
1,5	2	3000	2,34	10,7	41,7	0,95	2,13	3,9	19,7	0,83	2,10	4	21,5	0,73
2,2	3	4000	3,28	14,7	61,8	0,97	2,91	5,4	28,3	0,82	3,00	5,8	30,9	0,72
3	4	4000	-	-	-	-	3,99	7,4	39,9	0,82	4,09	7,9	43,6	0,72
4	5,5	6500	-	-	-	-	5,24	9,7	54,1	0,82	5,38	10,4	59,1	0,72
5,5	7,5	6500	-	-	-	-	7,05	12,6	73,3	0,85	7,08	12,8	80,1	0,77
7,5	10	6500	-	-	-	-	9,74	17,2	94,3	0,86	9,74	17,6	103	0,77

OIL FILLED MOTORS CABLE SELECTION

EXAMPLE : MOTOR 0.75 kW 230 V CABLE LENGTH 75 m - 4x2,5 mm²

Single phase 230 V

POWER		CABLE TYPE AND MAXIMUM LENGTH (*)							
[kW]	[HP]	4x1	4x1,5	4x2	4x2,5	4x4	4x6	4x10	4x16
0.37	0.5	50	75	100	125	-	-	-	-
0.55	0.75	38	57	76	95	152	-	-	-
0.75	1	30	45	60	75	120	174	-	-
1.1	1.5	22	33	43	53	85	127	210	-
1.5	2	-	23	31	38	63	92	154	246
2.2	3	-	-	22	28	45	67	112	180

Three phase 380-415 V

POWER		CABLE TYPE AND MAXIMUM LENGTH (*)							
[kW]	[HP]	4x1	4x1,5	4x2	4x2,5	4x4	4x6	4x10	4x16
0.37	0.5	240	-	-	-	-	-	-	-
0.55	0.75	164	246	328	-	-	-	-	-
0.75	1	133	200	266	333	-	-	-	-
1.1	1.5	97	146	195	244	390	-	-	-
1.5	2	72	109	145	180	290	435	-	-
2.2	3	51	78	103	130	207	310	516	-
3	4	41	62	83	104	167	250	416	-
4	5.5	31	46	62	77	124	186	310	496
5.5	7.5	-	33	45	56	90	135	225	360
7.5	10	-	-	-	-	66	100	165	270

(*) Maximum cable length with a voltage drop of 3% at 30°C ambient temperature.

If the operating voltage U_i in the installation is different from the nominal voltage U_n , it is possible to calculate the permissible maximum length L_{max} , with the given table length L_{tab} , with the following formula:

$$L_{max} = L_{tab} (U_i / U_n)^2$$

WATER FILLED MOTORS CABLE SELECTION

EXAMPLE : MOTOR 0.75 kW 230 V CABLE LENGTH 73 m - 4x2,5 mm²

Single phase 230 V

POWER		CABLE TYPE AND MAXIMUM LENGTH (*)							
[kW]	[HP]	4x1	4x1,5	4x2	4x2,5	4x4	4x6	4x10	4x16
0.37	0.5	50	76	101	126	-	-	-	-
0.55	0.75	39	58	77	97	155	-	-	-
0.75	1	29	44	58	73	117	175	-	-
1.1	1.5	20	30	40	50	79	119	198	-
1.5	2	-	23	31	39	62	93	156	249
2.2	3	-	-	23	28	45	68	113	181

Three phase 380-415 V

POWER		CABLE TYPE AND MAXIMUM LENGTH (*)							
[kW]	[HP]	4x1	4x1,5	4x2	4x2,5	4x4	4x6	4x10	4x16
0.37	0.5	325	-	-	-	-	-	-	-
0.55	0.75	223	335	446	-	-	-	-	-
0.75	1	167	251	335	418	-	-	-	-
1.1	1.5	120	179	239	299	478	-	-	-
1.5	2	86	129	172	215	343	515	-	-
2.2	3	61	91	122	152	243	365	609	-
3	4	45	67	89	112	179	268	446	-
4	5.5	34	51	68	85	135	203	338	541
5.5	7.5	-	40	53	66	106	159	266	425
7.5	10	-	-	-	-	78	117	196	313

(*) Maximum cable length with a voltage drop of 3% at 30°C ambient temperature.

If the operating voltage U_i in the installation is different from the nominal voltage U_n , it is possible to calculate the permissible maximum length L_{max} , with the given table length L_{tab} , with the following formula:

$$L_{max} = L_{tab} (U_i / U_n)^2$$