

EBARA

	Page
- SPECIFICATIONS	200
SELECTION CHART	201
TYPE KEY AND CURVE SPECIFICATIONS	202
PERFORMANCE CURVE JE 80	203
PERFORMANCE CURVE JE 100	204
PERFORMANCE CURVE JE 120	205
PERFORMANCE CURVE JE 150	206
- CONSTRUCTIONS	300
SECTIONAL VIEW	300
MECHANICAL SEAL	301
- DIMENSIONS AND WEIGHT	400
PUMP	400
PACKING	401
- TECHNICAL DATA	500
MOTOR DATA	500
NOISE DATA	500
- INSTALLATION	600

PUMP		
Liquid Handled	Type of liquid	Clean water
	Temperature [°C]	min. +5 max. +45
Maximum working pressure	[MPa]	0.6
Maximum suction depth	[m]	8
Construction	Impeller	Closed centrifugal type
	Shaft seal type	Mechanical seal
	Bearing	Sealed ball bearing
Pipe Connection	Suction [inch]	G 1¼ UNI ISO 228
	Discharge [inch]	G 1 UNI ISO 228
Material	Casing	AISI 304
	Impeller	AISI 304
	Shaft seal	Ceramic/Carbon/NBR
	Casing cover	AISI 304
	Shaft	AISI 303 (Wet extension)
	Bracket	AISI 304
	Ejector	PPE+PS glass fibre reinforced
	Diffuser	PPE+PS glass fibre reinforced
Applicable standard of test		ISO 9906 – Annex A

MOTOR		
Type	Electric - TEFC	
	Single Phase	Three Phase
Efficiency level (Reg. 640/2009)	-	- only for 0.6 kW IE2 from 0.75 kW up to 1.1 kW IE3 from 0.75 kW up to 1.1 kW
No. of Poles	2	
Rotation speed [min ⁻¹]	≈ 2800	
Insulation Class	F	
Protection degree (CEI EN 60034-5)	IP 44 IP 55 (on request)	
Power rating [kW]	0.6 ÷ 1.1	
[HP]	0.8 ÷ 1.5	
Frequency [Hz]	50	
Voltage [V]	230 ±10%	230/400 ±10%
Capacitor	Built in	-
Over load protection	Built in	Provided by the user
Casing material	AISI 304	
Base material/motor support	AISI 304	
Dimensions of cable entry	PG11 - (see dimensions page 400)	

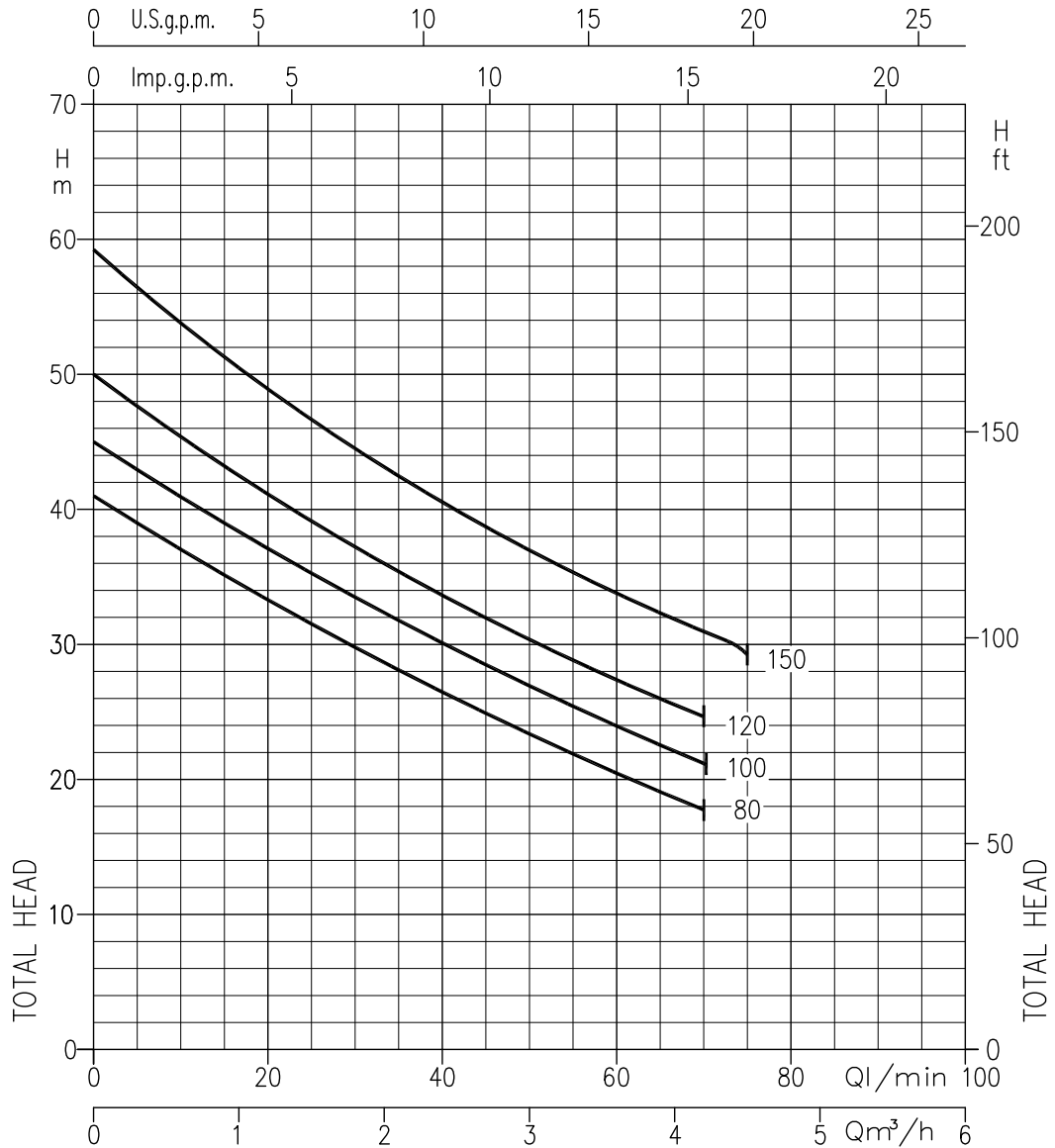

Pumptype		Power		Q=Capacity								
Single Phase	Three Phase	[kW]	[HP]	l/min	0	20	30	40	50	60	70	75
				m³/h	0	1.2	1.8	2.4	3	3.6	4.2	4.5
JEM 80	JE 80	0.6	0.8	41	33	29	26.5	23.5	20.5	18	-	-
JEM 100	JE 100	0.75	1	45	37	33.5	30	27	24	21	-	-
JEM 120	JE 120	0.88	1.2	50	41	37	34	30.5	27.5	24.5	-	-
JEM 150	JE 150	1.1	1.5	59	49	44.5	40.5	37	34	31	29.5	-

TYPE KEY

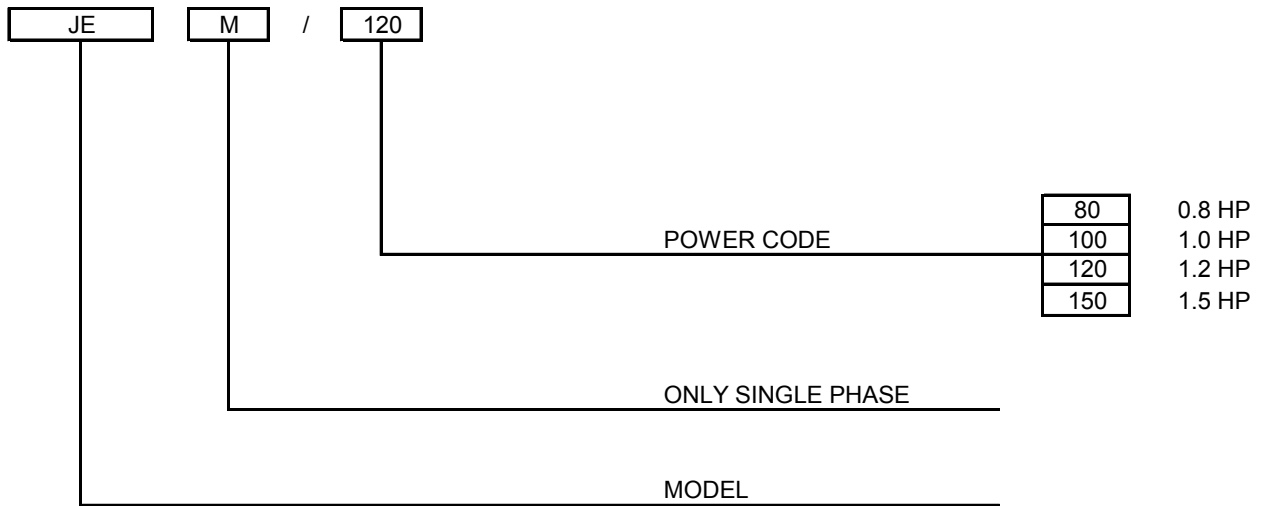

PERFORMANCE CURVE SPECIFICATIONS

The specifications below qualify the curves shown on the following pages.

Tolerances according to ISO 9906 Annex A

The curves refer to effective speed of asynchronous motors at 50 Hz

Measurements were carried out with clean water at 20°C of temperature and with a kinematic viscosity of $\nu = 1 \text{ mm}^2/\text{s}$ (1 cSt)

The continuous curves indicate the recommended working range. The dotted curve is only a guide.

In order to avoid the risk of over-heating, the pumps should not be used at a flow rate below 10% of best efficiency point.

Symbols explanation:

- Q = volume flow rate
- H = total head

JE 80 (0.6 kW) - Impeller diameter = 132 mm

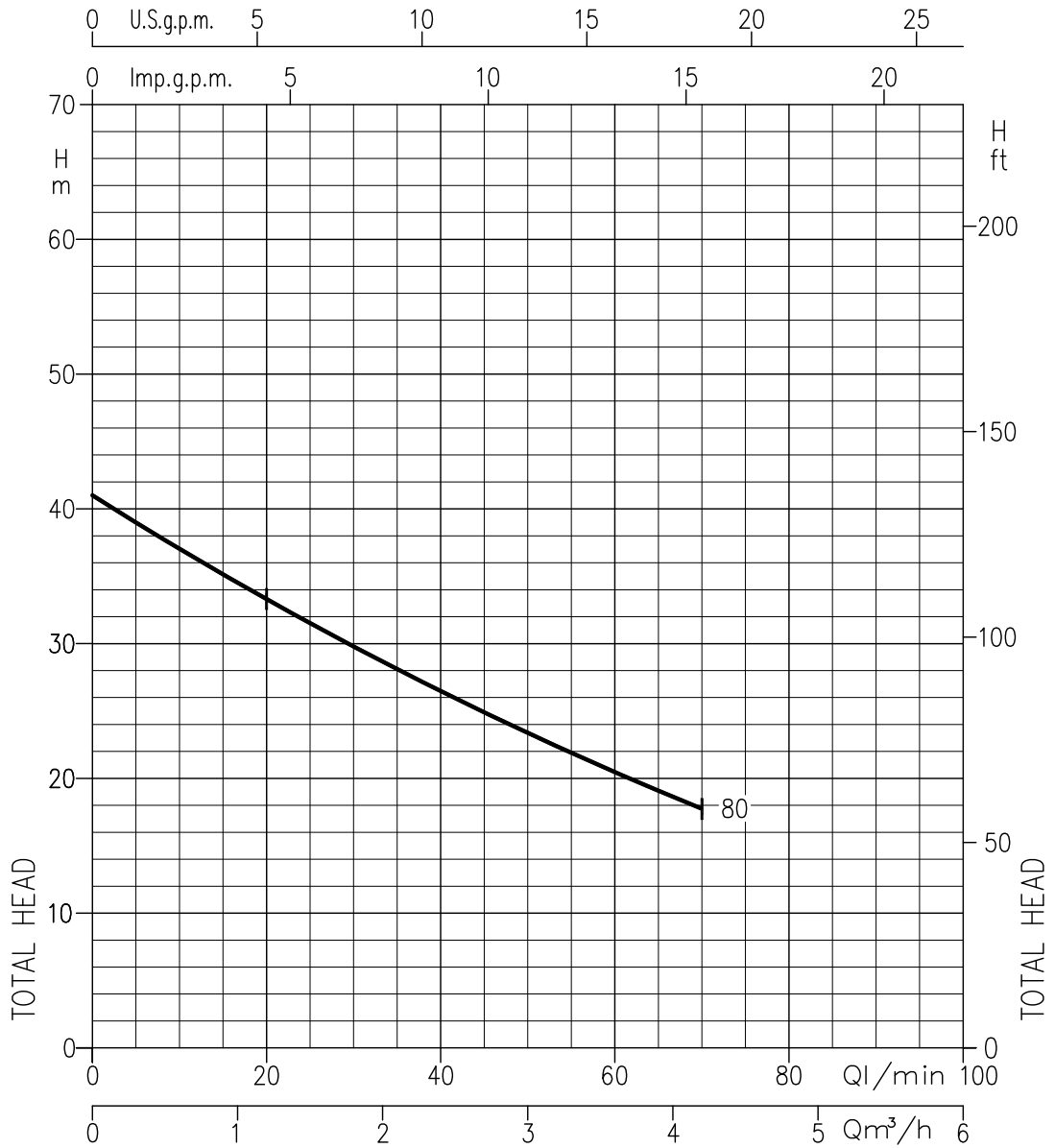

Rotation speed $\approx 2800 \text{ min}^{-1}$
Test standard: ISO 9906 – Annex A

JE 100 (0.75 kW) - Impeller diameter = 141 mm

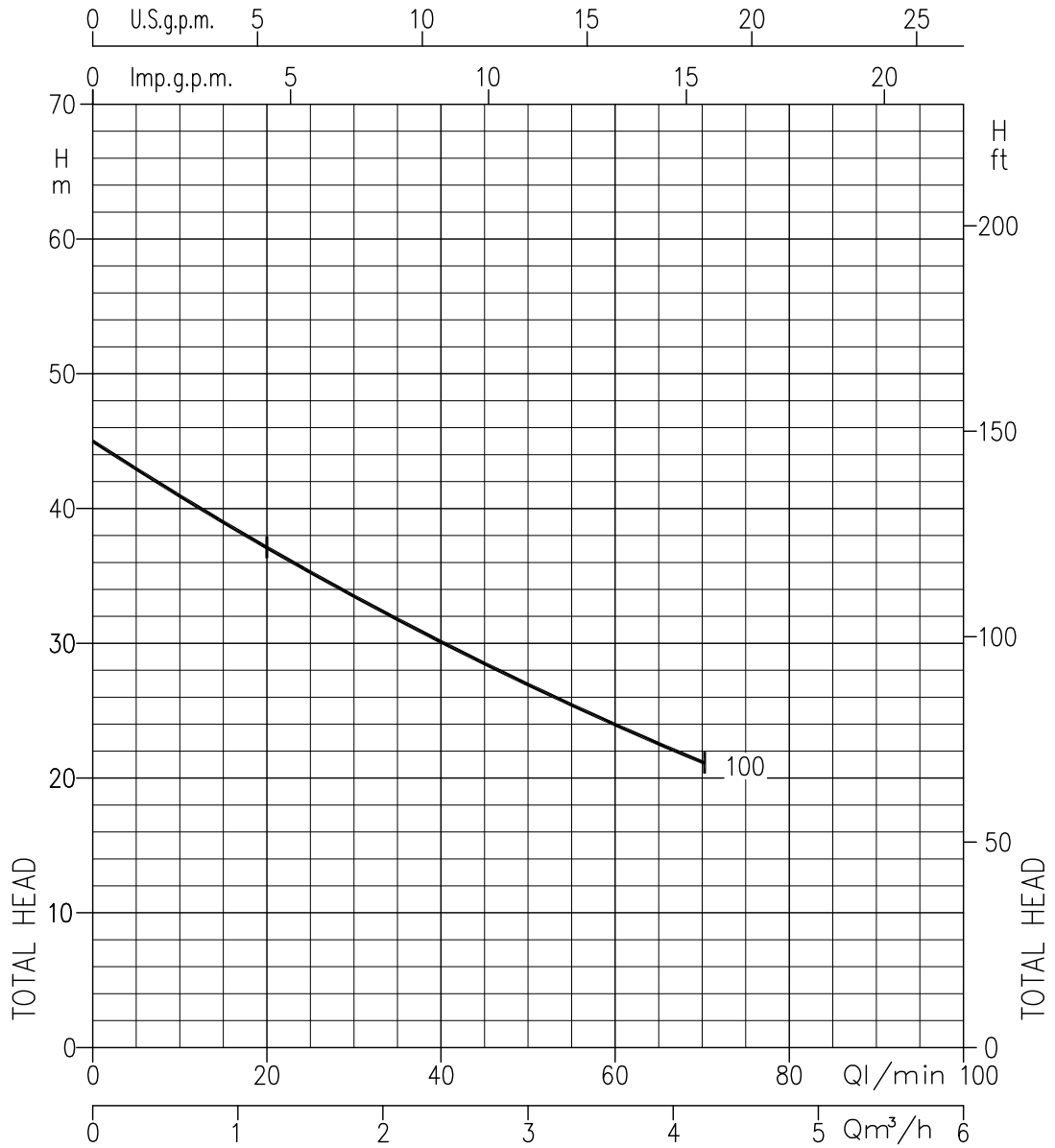

Rotation speed $\approx 2800 \text{ min}^{-1}$
Test standard: ISO 9906 – Annex A

JE 120 (0.88 kW) - Impeller diameter = 141 mm

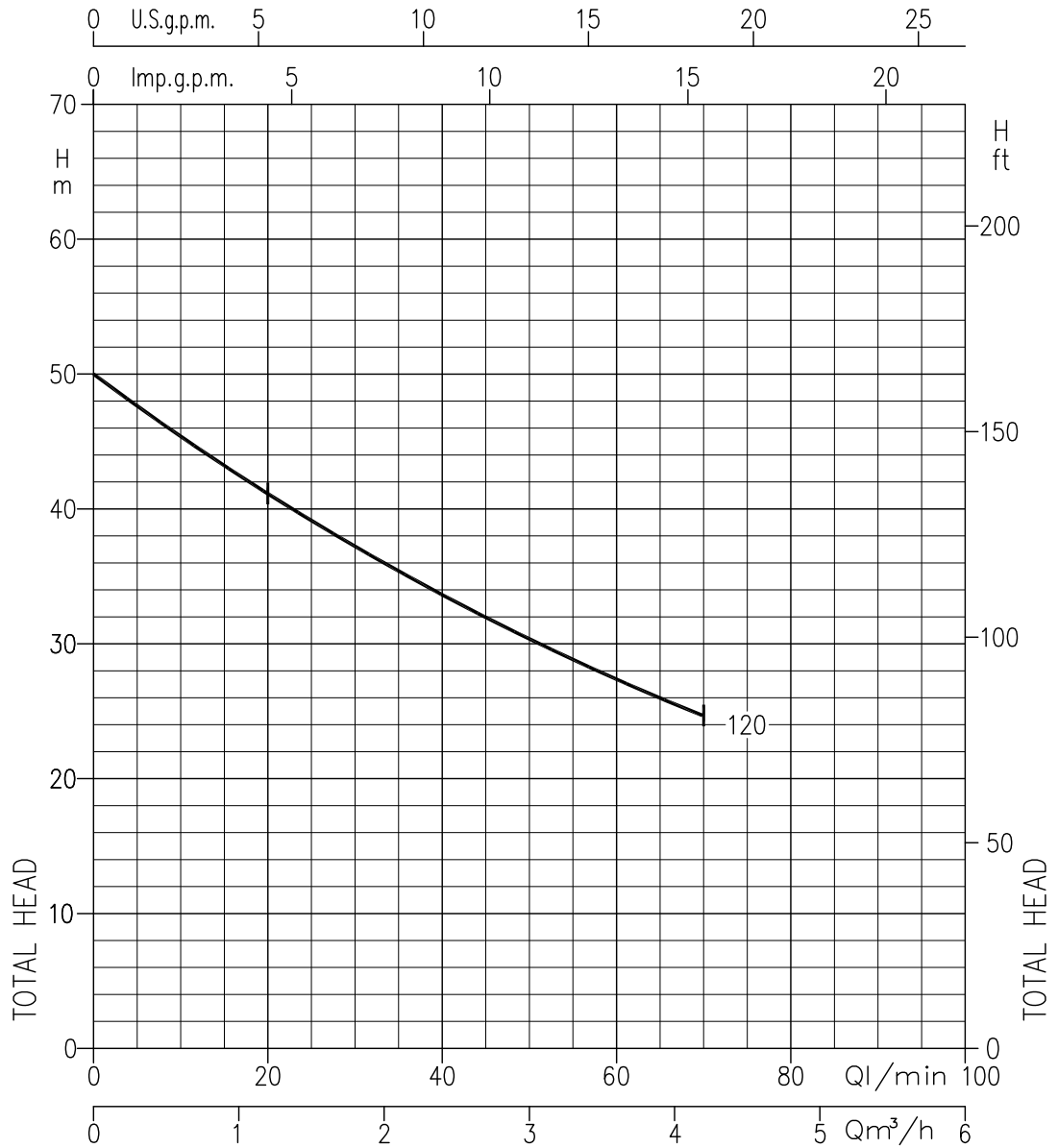

Rotation speed \approx 2800 min⁻¹
Test standard: ISO 9906 – Annex A

JE 150 (1.1 kW) - Impeller diameter = 141 mm

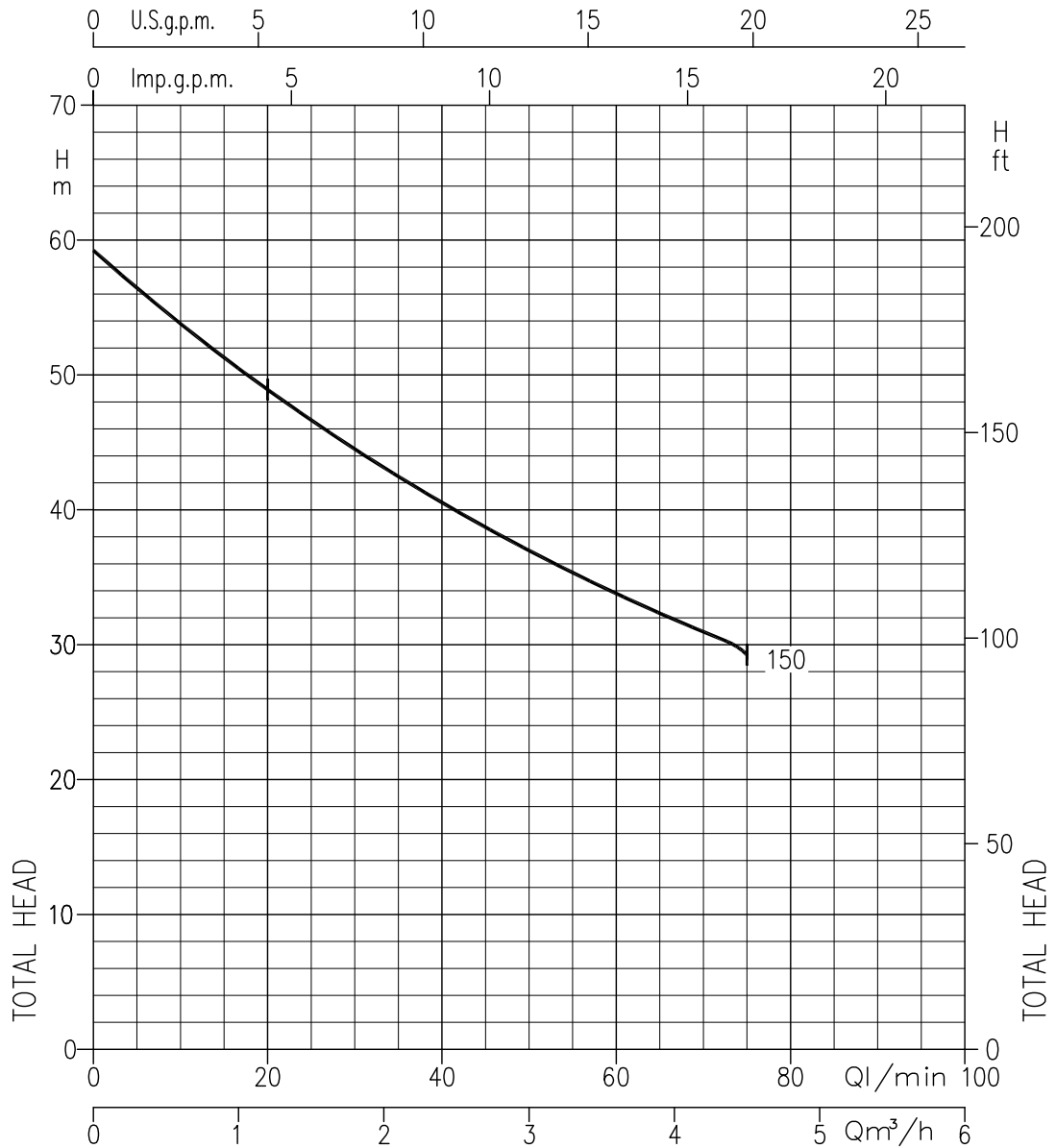

Rotation speed \approx 2800 min⁻¹
Test standard: ISO 9906 – Annex A

SECTIONAL VIEW

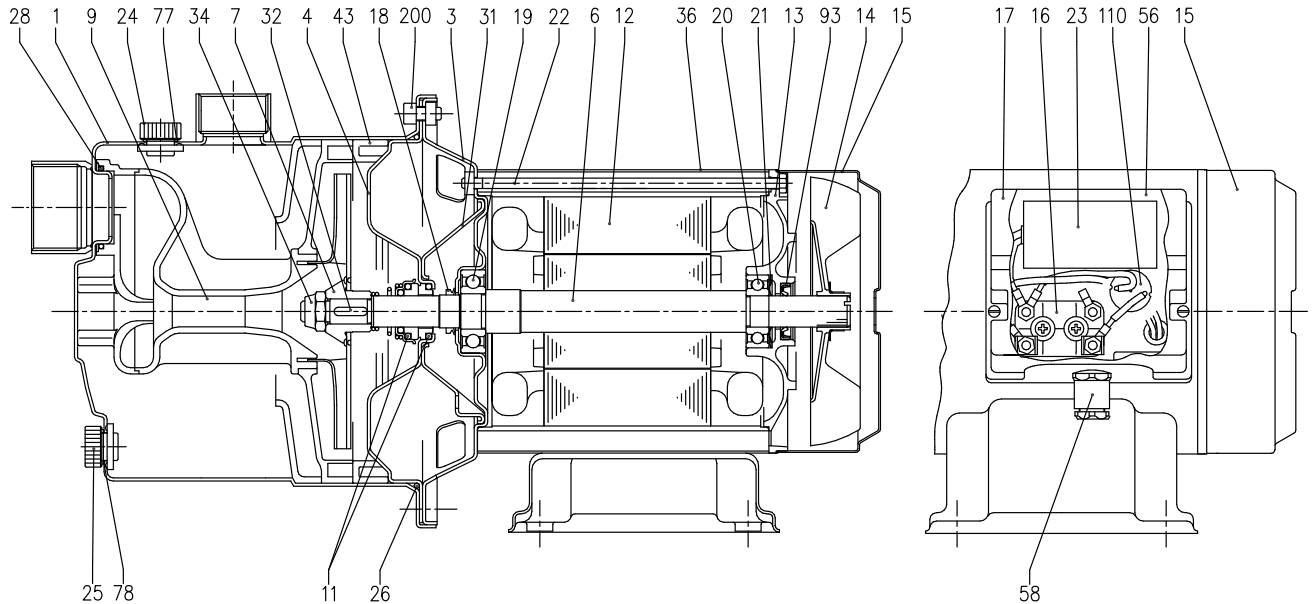

N°	PART NAME	MATERIAL	Q.TY	N°	PART NAME	MATERIAL	Q.TY
1	Casing	AISI 304	1	23	Capacitor [1]	-	1
3	Motor bracket	AISI 304	1	24	Priming plug	PA	1
4	Casing cover	AISI 304	1	25	Drain plug	PA	1
6	Shaft with rotor	AISI 303 (Wet extension)	1	26	O-ring	NBR	1
7	Impeller	AISI 304	1	28	O-ring	NBR	1
9	Diffuser Venturi tube	PPE+PS glass fibre reinforced	1	31	Thrust flange	AISI 304	1
11	Mechanical seal	Ceramic/Carbon/NBR	1	32	Key	AISI 304	1
12	Motor frame with stator	-	1	34	Impeller nut	AISI 304	1
13	Motor cover	Aluminium	1	36	External motor casing	AISI 304	1
14	Fan	PA	1	43	Space diffuser	PPE+PS glass fibre reinforced	1
15	Fan cover	AISI 304	1	56	Box gasket	NBR	1
16	Terminal board	-	1	58	Cable entry	-	1
17	Terminal box cover	PA66 glass fibre reinforced class V-0	1	77	O-ring	NBR	1
18	Splash ring	NBR	1	78	O-ring	NBR	1
19	Pump side ball bearing	-	1	93	Lip seal [2]	NBR	1
20	Fan side ball bearing	-	1	110	Protector [1]	-	1
21	Adjusting ring	Steel C70	1	200	Screw	Stainless steel A2 UNI7323	8
22	Tie rod	Fe 420 Zincate	4	-	-	-	-

[1] Only for single phase

[2] Only for IP55

MECHANICAL SEAL

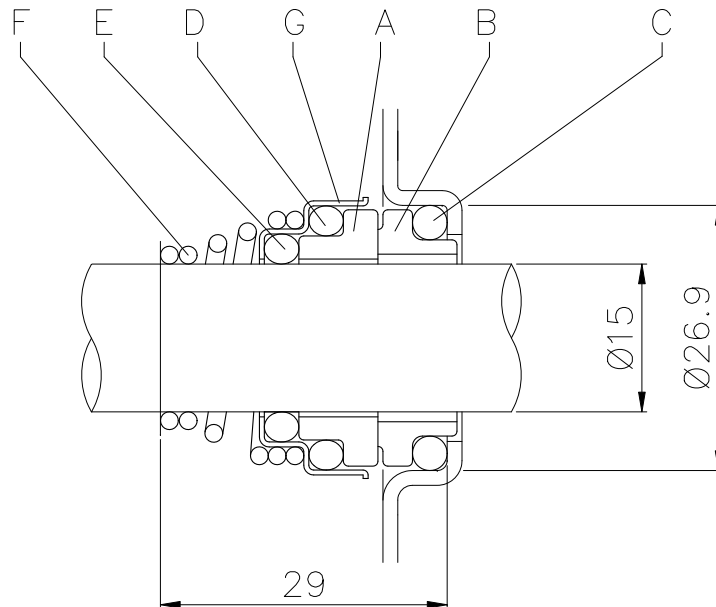

REF	PART NAME	MATERIAL
A	Rotary seal ring	Ceramic
B	Stationary seal ring	Carbon graphite
C	O Ring	NBR
D	O Ring	NBR
E	O Ring	NBR
F	Self driving spring	AISI 316
G	Frame	AISI 304

BEARINGS

Pump type		Ball Bearing			
Single Phase	Three Phase	Pump side	(*)	Fan side	(*)
			Pump side		Fan side
JEM 80	JE 80	6203 2RSH	-	6202 2RSH	-
JEM 100	JE 100	6203 2RSH	6203-ZZ C3	6202 2RSH	6202-ZZ C3
JEM 120	JE 120	6203 2RSH	6203-ZZ C3	6202 2RSH	6202-ZZ C3
JEM 150	JE 150	6204 2RSH	6204-ZZ C3	6203 2RSH	6203-ZZ C3

(*) Only for IE3 Motors

PUMP

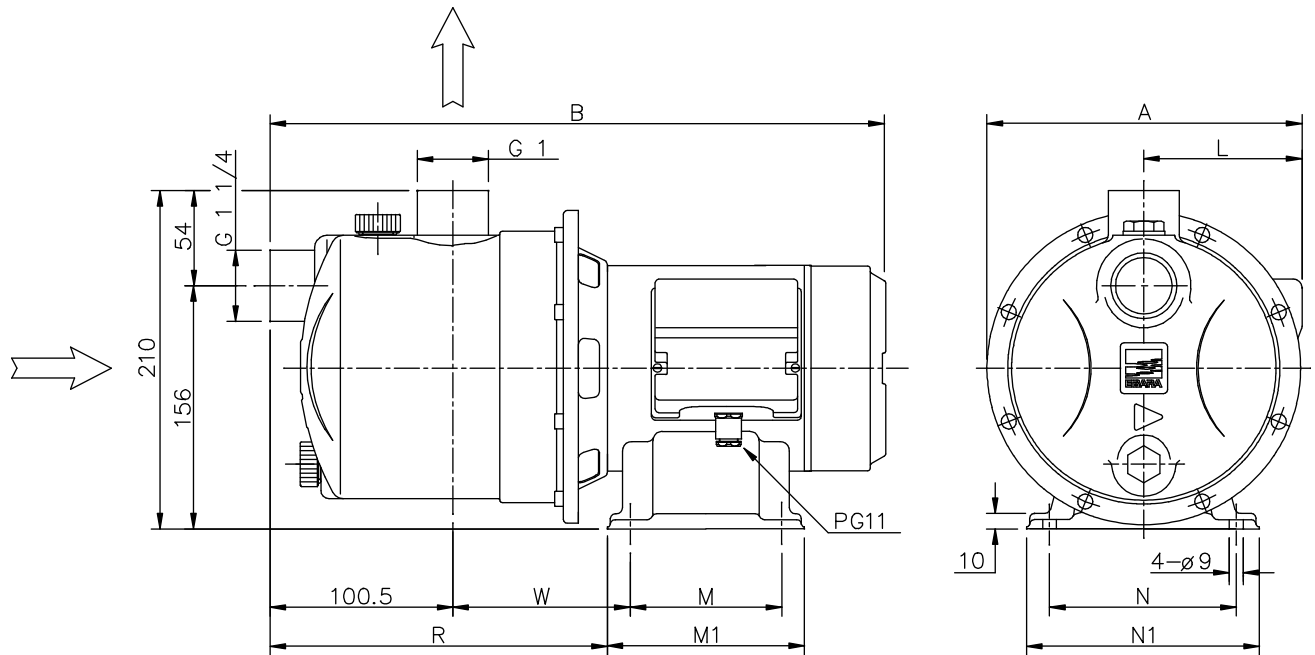

Pump type	Dimensions [mm]													Weight [kgf]		
	A		B			L		M	M1	N	N1	R	W	[1~]	[3~]	(*)
	[1~]	[3~]	[1~]	[3~]	(*)	[1~]	[3~]								[3~]	
80	211	208	396	396	-	107	103	100	131	120	150	213	128	10.5	10.5	-
100	211	208	426	426	426	107	103	100	131	120	150	228	143	12	12	12
120	211	208	426	426	426	107	103	100	131	120	150	228	143	12.5	12.5	12.5
150	215.5	215.5	433.5	433.5	443.5	111.5	111.5	120	150	140	170	231	145.5	14.1	16.4	17.3

[1~] Single phase
 [3~] Three phase
 (*) Only for IE3 Motors

PACKING

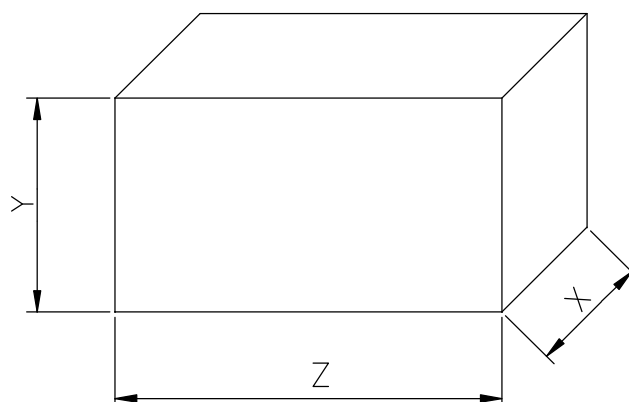

Pump type		Packing [mm]						Weight [kgf]		
Single Phase	Three Phase	X		Y		Z		[1~]	[3~]	(*)
			(*)		(*)		(*)			[3~]
JEM 80	JE 80	240	-	240	-	440	-	12	12	-
JEM 100	JE 100	240	240	240	240	440	440	13.5	13.5	13.5
JEM 120	JE 120	240	240	240	240	440	440	13.5	13.5	13.5
JEM 150	JE 150	240	239	240	225	440	457	15.5	17.4	18.3

[1~] Single phase

[3~] Three phase

(*) Only for IE3 Motors

MOTOR DATA

Pump type		Power		Efficiency		Capacitor		Efficiency (% load)			Input		Full load current			Locked rotor current			
Single Phase	Three Phase	[kW]	[HP]	Single Phase	Three Phase	Single Phase	Single Phase	Three phase			Single Phase	Three Phase	Single Phase	Three Phase	Three Phase	Single Phase	Three Phase	Three Phase	
						[μF]	[V]	50%	75%	100%	Phase	Phase	230 V	230 V	400 V	230 V	230 V	400 V	
JEM 80	JE 80	0,6	0,8	-	-	16	450	-	-	-	1,05	0,97	4,7	3,3	1,9	16,1	17,0	9,7	
JEM 100	JE 100	0,75	1,0	-	IE2	20	450	77,2	80,9	81,3	1,33	1,13	6,4	3,5	2,0	22,7	22,0	12,9	
-	JE 100	0,75	1,0	-	IE3	-	-	80,9	82,3	82,1	-	0,91	-	3,0	1,7	-	-	19,7	11,4
JEM 120	JE 120	0,88	1,2	-	IE2	20	450	77,2	80,9	81,3	1,39	1,15	6,7	3,6	2,1	22,7	22,0	12,9	
-	JE 120	0,88	1,2	-	IE3	-	-	80,9	82,3	82,1	-	0,91	-	3,0	1,7	-	-	19,7	11,4
JEM 150	JE 150	1,1	1,5	-	IE2	35	450	79,7	82,5	83,0	1,70	1,80	7,6	5,6	3,2	41	45,0	25,7	
-	JE 150	1,1	1,5	-	IE3	-	-	83,0	85,8	85,6	-	1,77	-	5,8	3,3	-	-	47,4	27,4

NOISE DATA

Pump type		Power		L _{pA} - dB(A) *
Single Phase	Three Phase	[kW]	[HP]	
JEM 80	JE 80	0.6	0.8	71
JEM 100	JE 100	0.75	1.0	
JEM 120	JE 120	0.88	1.2	
JEM 150	JE 150	1.1	1.5	76

* Mean value of several measures at 1m distance around the pump.

Tolerance ± 2.5 dB.

If you use this pump on suction condition , it tends to breath the air from outside because the pressure in pump becomes vaccum condition when it stopped. So water in the pump sometimes fall down to breath the air from pipe connection. If it is used to operate continuously under this condition, this is the cause of breakdown to overheat inside the pump.



So please install foot valve or check valve at suction pipe in order to prevent the pump from such a condition. And moreover will you please support the suction pipe and the delivery one to prevent the pump from leaning the weight of pipe.

