

**EBARA**

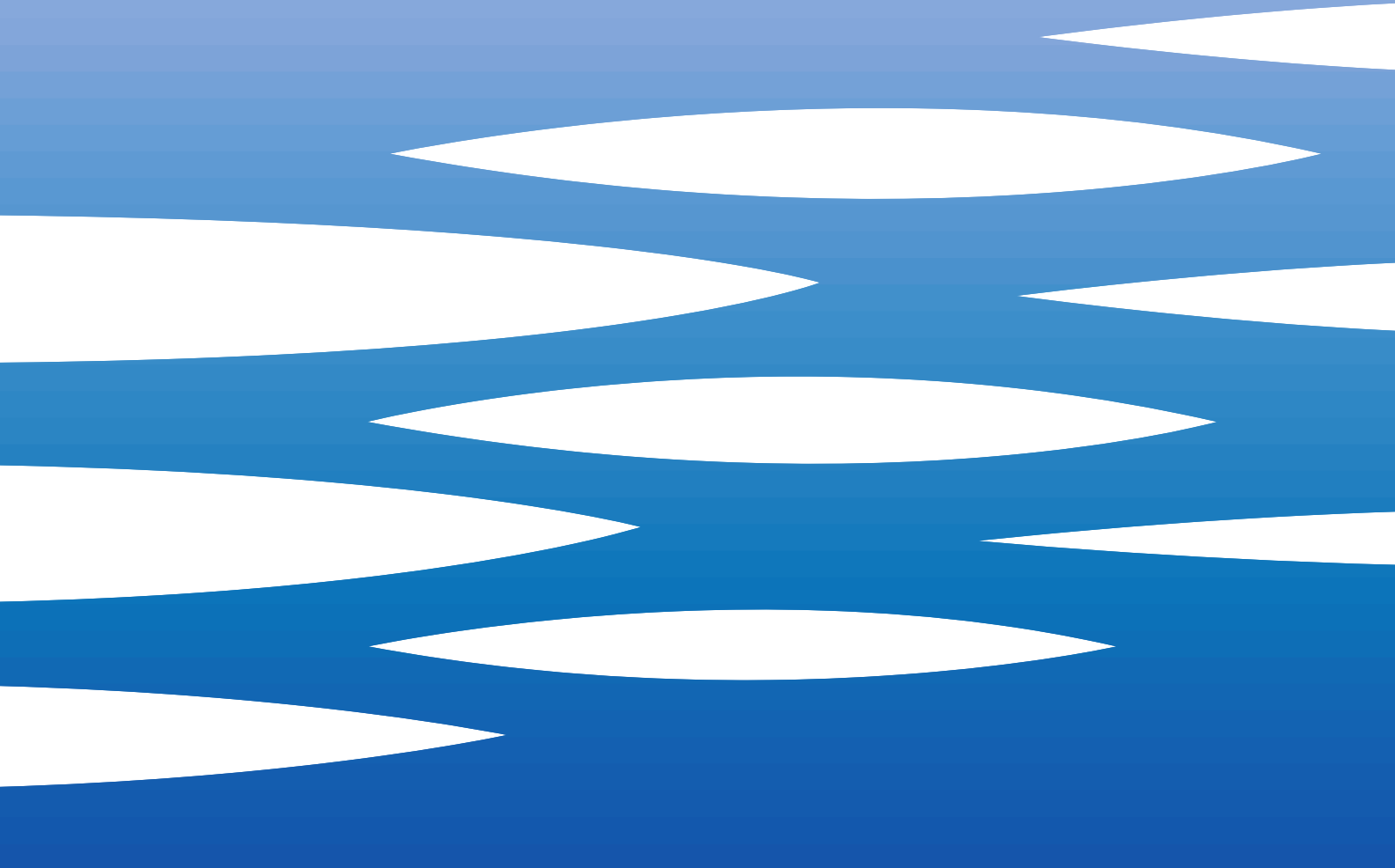

	Page
<b>- SPECIFICATIONS</b>	
PUMP SPECIFICATIONS	200
PUMP SPECIFICATIONS	201
SELECTION CHART	202
SELECTION CHART	203
SELECTION CHART	204
PERFORMANCE CURVE 32-125	205
PERFORMANCE CURVE 32-160	206
PERFORMANCE CURVE 32-200	207
PERFORMANCE CURVE 40-125	208
PERFORMANCE CURVE 40-160	209
PERFORMANCE CURVE 40-200	210
PERFORMANCE CURVE 50-125	211
PERFORMANCE CURVE 50-160	212
PERFORMANCE CURVE 50-200	213
PERFORMANCE CURVE 65-125	214
PERFORMANCE CURVE 65-160	215
PERFORMANCE CURVE 65-200	216
PERFORMANCE CURVE 65-250	217
PERFORMANCE CURVE 80-160	218
PERFORMANCE CURVE 80-200	219
PERFORMANCE CURVE 80-250	220
<b>- CONSTRUCTIONS</b>	
SECTIONAL VIEW 3SF-3LSF (32,40,50,65-125/160/200)	300
CONSTRUCTIONS 3SF-3LSF (32,40,50,65-125/160/200)	301
SECTIONAL VIEW 3LSF 80-160	302
CONSTRUCTIONS 3LSF 80-160	303
SECTIONAL VIEW 3LSF (65-250, 80-200/250)	304
CONSTRUCTIONS 3LSF (65-250, 80-200/250)	305
SECTIONAL VIEW 3PF-3LPF (32,40,50,65-125/160/200)	306
CONSTRUCTIONS 3PF-3LPF (32,40,50,65-125/160/200)	307
SECTIONAL VIEW 3LPF 80-160	308
CONSTRUCTIONS 3LPF 80-160	309
SECTIONAL VIEW 3LPF (65-250, 80-200/250)	310
CONSTRUCTIONS 3LPF (65-250, 80-200/250)	311
CONSTRUCTIONS: BALL BEARING	312
CONSTRUCTIONS: MECHANICAL SEAL (standard and H version)	313
CONSTRUCTIONS: MECHANICAL SEAL (L version Ø 22)	314
CONSTRUCTIONS: MECHANICAL SEAL (L version)	315
CONSTRUCTIONS: MECHANICAL SEAL (HS version Ø 22)	316
CONSTRUCTIONS: MECHANICAL SEAL (HS and E version)	317

	Page
CONSTRUCTIONS: COUPLING	318
CONSTRUCTIONS: COUNTERFLANGE	319
CONSTRUCTIONS: COUNTERFLANGE	320
<b>- DIMENSIONS</b>	
DIMENSIONS 3SF-3LSF (32,40,50)	400
DIMENSIONS 3SF-3LSF (32,40,50,65)	401
DIMENSIONS 3LSF (65-250,80)	402
DIMENSIONS 3PF-3LPF (32-40-50-65)	403
DIMENSIONS 3LPF (65-250,80)	404
PACKING AND WEIGHT 3SF-3LSF	405
PACKING AND WEIGHT 3PF-3LPF	406

**PUMP SPECIFICATIONS**

50 Hz

Rev. G

			Version	<b>3SF</b>	<b>3PF</b>	<b>3LSF</b>	<b>3LPF</b>
Pump sizes			32-125	■	■	■	■
			32-160	■	■	■	■
			32-200	■	■	■	■
			40-125	■	■	■	■
			40-160	■	■	■	■
			40-200	■	■	■	■
			50-125	■	■	■	■
			50-160	■	■	■	■
			50-200	■	■	■	■
			65-125	■	■	■	■
			65-160	■	■	■	■
			65-200	■	■	■	■
			65-250	-	-	●	●
			80-160	-	-	●	●
			80-200	-	-	●	●
80-250	-	-	●	●			
Liquid Handled	Type of liquid		Clean water and moderately aggressive fluids				
			/		Clean water, drinking water, water contains glycol for E version		
	Temperature	min.	[°C]	-10		-10 -20 for E version	
max.		+90 110 for (H-HS version)		+110 +120 for E version			
Maximum working pressure			[MPa]	1			

■ Available also with H and HS option for 32, 40, 50, 65-125/160/200.

● Available also with H and E option for 65-250, 80.

— Not available.

## PUMP SPECIFICATIONS

50 Hz

Rev. G

Version			3SF	3PF	3LSF	3LPF	
Construction	Impeller		Closed centrifugal type for [32, 40, 50 version] Reinforced laser welding for [40-200/11, 50-200/15] Closed centrifugal three dimensional blades for [65 and 80 version]				
	Shaft seal type		Mechanical seal		Mechanical seal with stationary ring secured against rotation. Mechanical seal for [H-E option]		
	Bearing		Sealed ball bearing				
Pipe Connection	Suction	32-125/160/200	Flange DN50 according DIN 2532 standard				
		40-125/160/200	Flange DN65 according DIN 2532 standard				
		50-125/160/200	Flange DN65 according DIN 2532 standard				
		65-125/160/200/250	Flange DN80 according DIN 2532 standard				
	Discharge	80-160/200/250	Flange DN100 according DIN 2532 standard				
		32-125/160/200	Flange DN32 according DIN 2532 standard				
		40-125/160/200	Flange DN40 according DIN 2532 standard				
		50-125/160/200	Flange DN50 according DIN 2532 standard				
		65-125/160/200/250	Flange DN65 according DIN 2532 standard				
		80-160/200/250	Flange DN80 according DIN 2532 standard				
Material	Casing	32-125/160/200	EN 1.4301 (AISI 304)		EN 1.4404 (AISI 316L)		
		40-125/160/200					
		50-125/160/200					
		65-125/160/200					
		65-250	/		EN 1.4401 (AISI 316) Made by precision casting		
	Impeller	32-125/160/200	EN 1.4301 (AISI 304)		EN 1.4404 (AISI 316L)		
		40-125/160/200					
		50-125/160/200					
			65-125/160/200	EN 1.4401 (AISI 316) Made by precision casting			
			65-250	/		EN 1.4401 (AISI 316) Made by precision casting	
			80-160/200/250	/		EN 1.4401 (AISI 316) Made by precision casting	
	Casing cover	32-125/160/200	EN 1.4301 (AISI 304)		EN 1.4404 (AISI 316L)		
		40-125/160/200					
		50-125/160/200					
		65-125/160/200					
			65-250	/		EN 1.4401 (AISI 316) Made by precision casting	
			80-160/200/250	/		EN 1.4401 (AISI 316) Made by precision casting	
	Mechanical seal	32-125/160/200		Ceramic/Carbon/NBR [standard version]		SiC/SiC/FPM [L version]	
		40-125/160/200		Ceramic/Carbon/FPM [H option]		SiC/SiC/FPM [L version]	
		50-125/160/200		SiC/SiC/FPM [HS option]		SiC/SiC/FPM [L version]	
		65-125/160/200			Ceramic/Carbon/FPM [H option]		
		65-250	/		SiC/Carbon/EPDM [E option]		
		80-160/200/250	/		SiC/Carbon/EPDM [E option]		
O-ring		NBR FPM for [H-HS option]		FPM			
Shaft	32, 40, 50	d=19	EN 1.4301 (AISI 304)		EN 1.4404 (AISI 316L)		
	65-125						
	65-160/11						
	50-200/15	d=22					
	65-160/15						
	65-200	d=24	/		EN 1.4462 (Duplex stainless steel)		
	65-250	d=24	/		EN 1.4404 (AISI 316L)		
	80-160	d=24	/		EN 1.4404 (AISI 316L)		
	80-200	d=24	/		EN 1.4462 (Duplex stainless steel)		
30-37kW	d=24	/		EN 1.4462 (Duplex stainless steel)			
80-250	d=29	/		EN 1.4462 (Duplex stainless steel)			
Bracket		Cast iron - aluminium					

SELECTION CHART

50 Hz

Rev. G

**TYPE KEY**

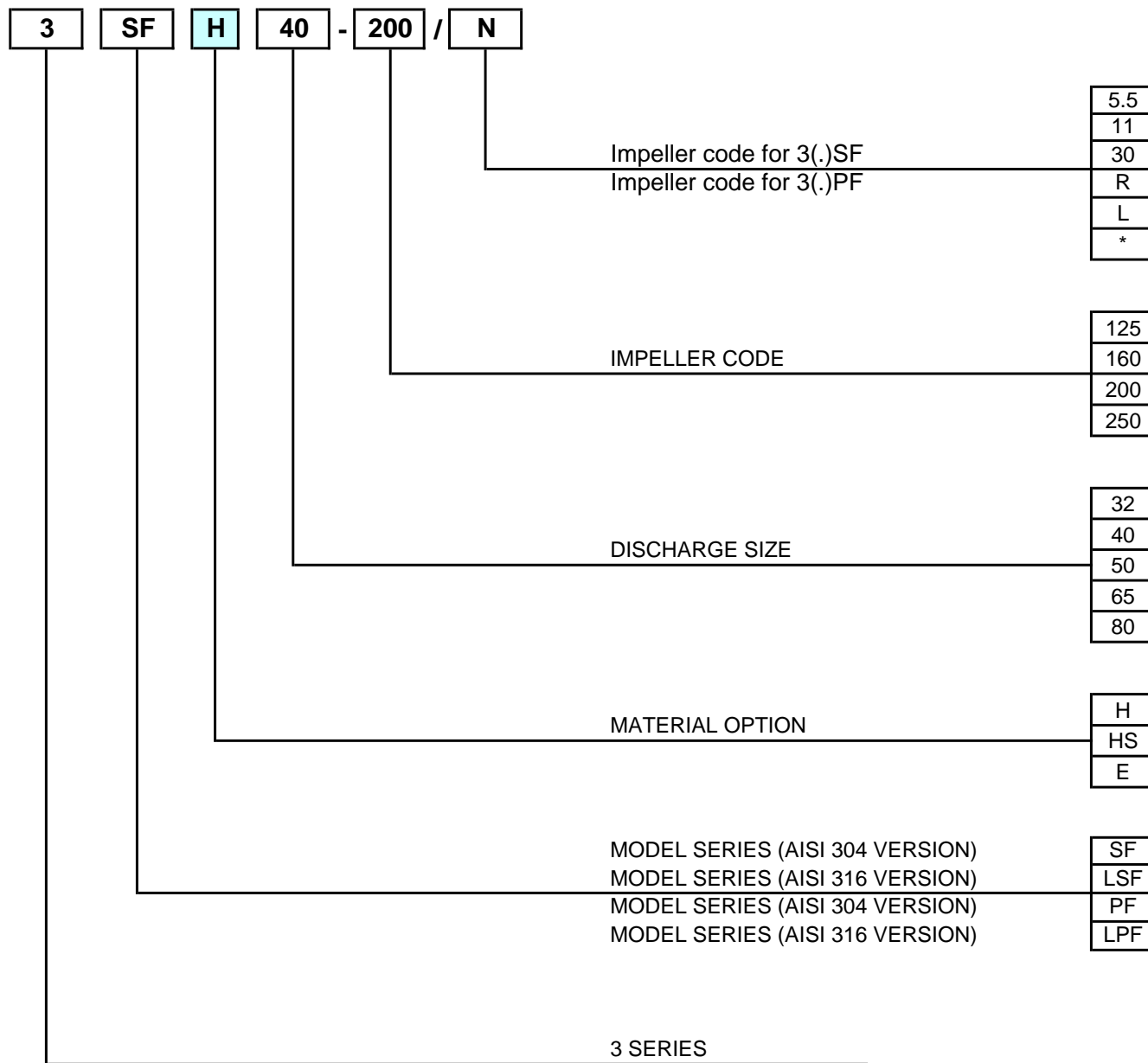

\*) No indication

SELECTION CHART

50 Hz

Rev. G

3 SERIES SF and PF VERSION: 32, 40, 50

Pump type		kW	HP	Flow rate															
3(.)SF	3(.)PF			l/min	0	100	150	200	300	333	360	400	450	500	600	700	800	1000	1200
		m³/h																	
		0	6	9	12	18	20	22	24	27	30	36	42	48	60	72			
32-125/1.1	32-125	1.1	1.5	22.5	21	19.9	18.4	14.1	12	-	-	-	-	-	-	-	-	-	
32-160/1.5	32-160/R	1.5	2	29.5	28	26.5	24.5	19.2	17	-	-	-	-	-	-	-	-	-	
32-160/2.2	32-160	2.2	3	37	35.5	34	32	27	25	-	-	-	-	-	-	-	-	-	
32-200/3	32-200/R	3	4	44	42	40	37.5	31	28	-	-	-	-	-	-	-	-	-	
32-200/4	32-200	4	5.5	55	53.5	52	49.5	43.5	40.5	38	-	-	-	-	-	-	-	-	
32-200/5.5	32-200/L	5.5	7.5	70.5	69	67.5	65	58.5	-	-	-	-	-	-	-	-	-	-	
32-200/7.5		7.5	10	70.5	69	67.5	65	58.5	55.5	53	49	44	-	-	-	-	-	-	
40-125/1.5	40-125/R	1.5	2	20	-	-	19	17.6	17	16.5	15.7	14.5	13.2	10.3	7	-	-	-	
40-125/2.2	40-125	2.2	3	26.5	-	-	25.5	24	23.5	23	22	21	19.5	16.4	13	-	-	-	
40-160/3	40-160/R	3	4	31	-	-	29.5	27.5	27	26.5	25.5	24	22.5	20	17	-	-	-	
40-160/4	40-160	4	5.5	40	-	-	38.5	37	36	35.5	34.5	33	32	29	25.5	-	-	-	
40-200/5.5	40-200/R	5.5	7.5	47	-	-	45.5	44	43	42.5	41	39.5	38	35	31	-	-	-	
40-200/7.5	40-200	7.5	10	58	-	-	57	55.5	55	54.5	53.5	52.5	51	47.5	44	-	-	-	
40-200/11	40-200/L	11	15	72	-	-	71	70	70	69.5	68.5	67.5	66	63	59	-	-	-	
50-125/2.2	50-125/S	2.2	3	19	-	-	-	-	-	-	17.5	17	16.3	14.9	13.4	11.7	8	-	
50-125/3	50-125/R	3	4	22	-	-	-	-	-	-	20.5	20	19.6	18.4	17	15.4	11.8	8	
50-125/4	50-125	4	5.5	26.5	-	-	-	-	-	-	26	25.5	25	24	22.5	21.5	17.9	14	
50-160/5.5	50-160/R	5.5	7.5	33	-	-	-	-	-	-	31	30.5	30	28.5	27	25.5	22	18	
50-160/7.5	50-160	7.5	10	40	-	-	-	-	-	-	38.5	38	37.5	36	35	33.5	30	26	
50-200/9.2	50-200/R	9.2	12.5	53	-	-	-	-	-	-	-	-	50	49	47.5	45.5	40.5	34	
50-200/11	50-200	11	15	59	-	-	-	-	-	-	-	-	56	55	54	52	48	42	
50-200/15	50-200/L	15	20	72	-	-	-	-	-	-	-	-	70	69	68	66	62	57	

3 SERIES SF and PF VERSION: 65, 80

Pump type		kW	HP	Flow rate																	
3(.)SF	3(.)PF			l/min	0	600	700	900	1300	1500	1700	1900	2100	2200	2300	2400	2500	3000	3400	3600	3800
		m³/h																			
		0	36	42	54	78	90	102	114	126	132	138	144	150	180	204	216	228	240		
65-125/4	65-125/R	4	5.5	22.2	19.8	19	17.3	13.3	11	8.6	6.3	-	-	-	-	-	-	-	-	-	-
65-125/5.5	65-125	5.5	7.5	27	-	24	22.2	18	15.7	13.3	10.8	8	-	-	-	-	-	-	-	-	-
65-125/7.5	65-125/L	7.5	10	32	-	29.5	27.8	23.5	21.1	18.7	16.1	13.4	12	-	-	-	-	-	-	-	-
65-160/7.5	65-160/S	7.5	10	32	-	30	28.6	24.8	22.5	19.9	17.1	14.2	-	-	-	-	-	-	-	-	-
65-160/9.2	65-160/R	9.2	12.5	36.5	-	34.5	32.8	28.8	26.5	23.9	21.1	18.3	16.8	-	-	-	-	-	-	-	-
65-160/11	65-160	11	15	40.5	-	38.5	37.1	33.1	30.9	28.4	25.8	23	21.5	20	-	-	-	-	-	-	-
65-160/15	65-160/L	15	20	48	-	45.5	44	40	37.8	35.3	32.6	29.6	28	26.5	-	-	-	-	-	-	-
65-200/15	65-200/R	15	20	53.5	-	51	49	44	41.5	38.4	35.3	31.8	30	-	-	-	-	-	-	-	-
65-200/18.5	65-200	18.5	25	60.5	-	58.5	56.5	51.5	49	46	43	39.7	38	36.3	-	-	-	-	-	-	-
65-200/22	65-200/L	22	30	67	-	65.5	64	59.5	57	54	51	48	46.5	45	-	-	-	-	-	-	-
65-250/30	65-250	30	40	78	-	-	77	73.5	71	68	64.5	60	57.5	55	52	-	-	-	-	-	-
65-250/37	65-250/L	37	50	89	-	-	88	85.5	83	80.5	77.5	74	72	70	67.5	65	-	-	-	-	-
80-160/11	80-160/S	11	15	29	-	-	-	27.3	26.4	25.4	24.2	23	22.4	21.8	21.1	20.4	16.4	12.5	-	-	-
80-160/15R	80-160/R	15	20	32	-	-	-	30.5	29.7	28.8	27.7	26.5	25.9	25.3	24.6	24	20.1	16.5	14.5	-	-
80-160/15	80-160	15	20	35	-	-	-	34	33.3	32.5	31.5	30.5	30	29.4	28.8	28.1	24.4	21	19.1	17	-
80-160/18.5	80-160/L	18.5	25	40	-	-	-	39	38.4	37.6	36.7	35.7	35.2	34.7	34.1	33.5	30	26.4	24.4	22.3	20
80-200/22	80-200/R	22	30	50	-	-	-	48	47	45.5	44.5	43	42	41	40	39	33.2	27.8	25	-	-
80-200/30	80-200	30	40	60	-	-	-	58.5	58	57	56	54.5	54	53	52	51	46.5	41.5	39	36.1	33
80-200/37	80-200/L	37	50	66	-	-	-	64	63	62	61	59.5	59	58	57.5	56.5	51.5	47	44.5	41.5	38.5
80-250/37	80-250/R	37	50	73	-	-	-	71.5	70.5	68.5	66.5	64	63	61.5	60	58.5	48.5	38	-	-	-
80-250/45	80-250	45	60	84	-	-	-	82.5	81.5	80	78	76	75	73.5	72.5	71	62	53	48	42.5	-
80-250/55	80-250/L	55	75	95	-	-	-	93.5	92.5	91.5	90	88.5	87.5	86.5	85.5	84	76.5	68.5	64.5	60	55

SELECTION CHART

50 Hz

Rev. G

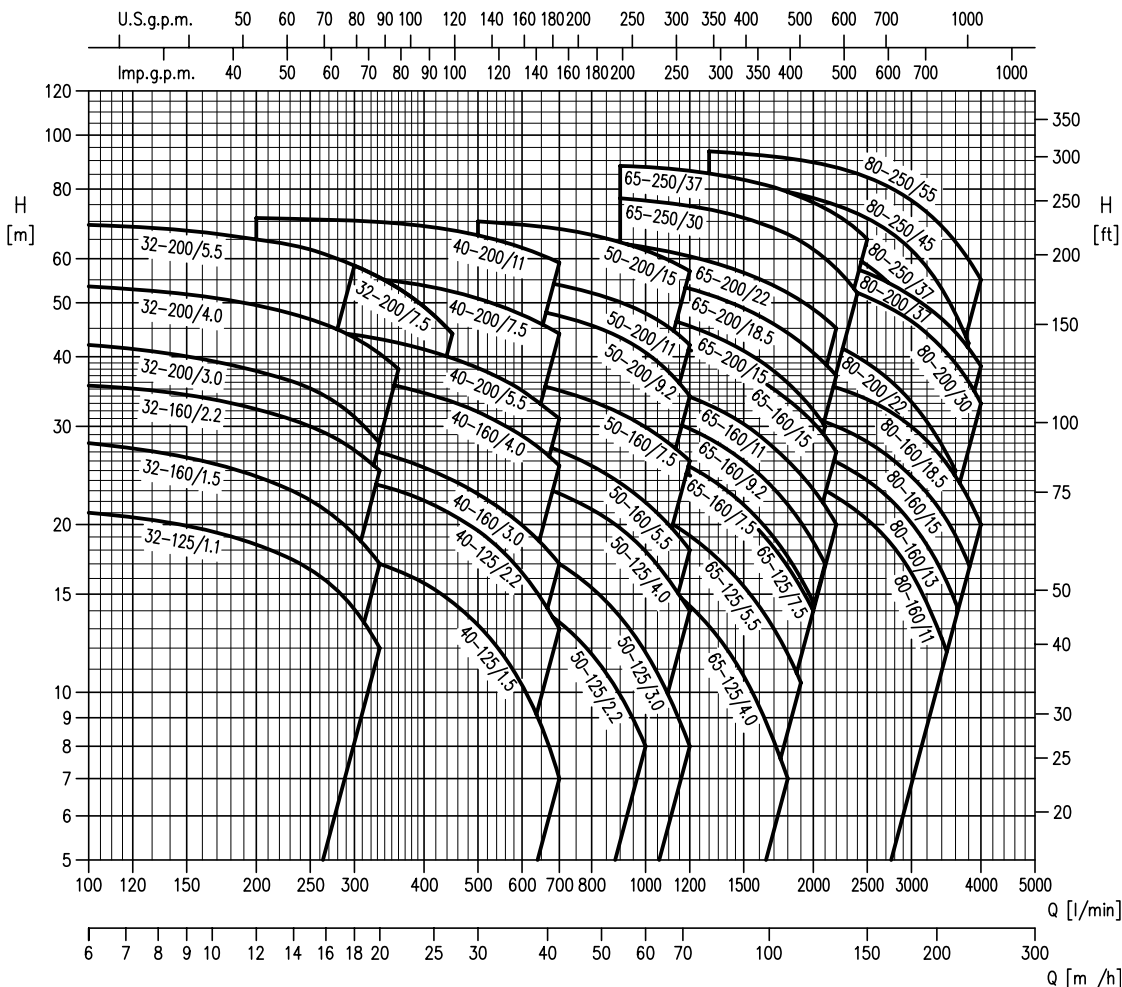

PERFORMANCE CURVES

The specifications below qualify the curves shown on the following pages.

- ◆ Tolerances according to ISO 9906 Annex A
- ◆ The curves refer to effective speed of asynchronous motors at 50 Hz
- ◆ Measurements were carried out with clean water at 20°C of temperature and with a kinematic viscosity of  $\nu = 1 \text{ mm}^2/\text{s}$  (1 cSt)
- ◆ The NPSH curve is an average curve obtained in the same conditions of performance curves. During the pump selection, consider to get a safety margin of at least 1 m.
- ◆ The continuous curves indicate the recommended working range. The dotted curve is only a guide.
- ◆ In order to avoid the risk of over-heating, the pumps should not be used at a flow rate below 10% of best efficiency point.
- ◆ Symbols explanation:
  - Q = volume flow rate
  - H = total head
  - $P_2$  = pump power input (shaft power)
  - $\eta$  = pump efficiency
  - NPSH = net positive suction head required by the pump



PERFORMANCE CURVE

50 Hz

Rev. G

3(.)SF 32-125/1.1 and 3(.)PF 32-125 (1.1kW) – impeller diameter = 133 mm

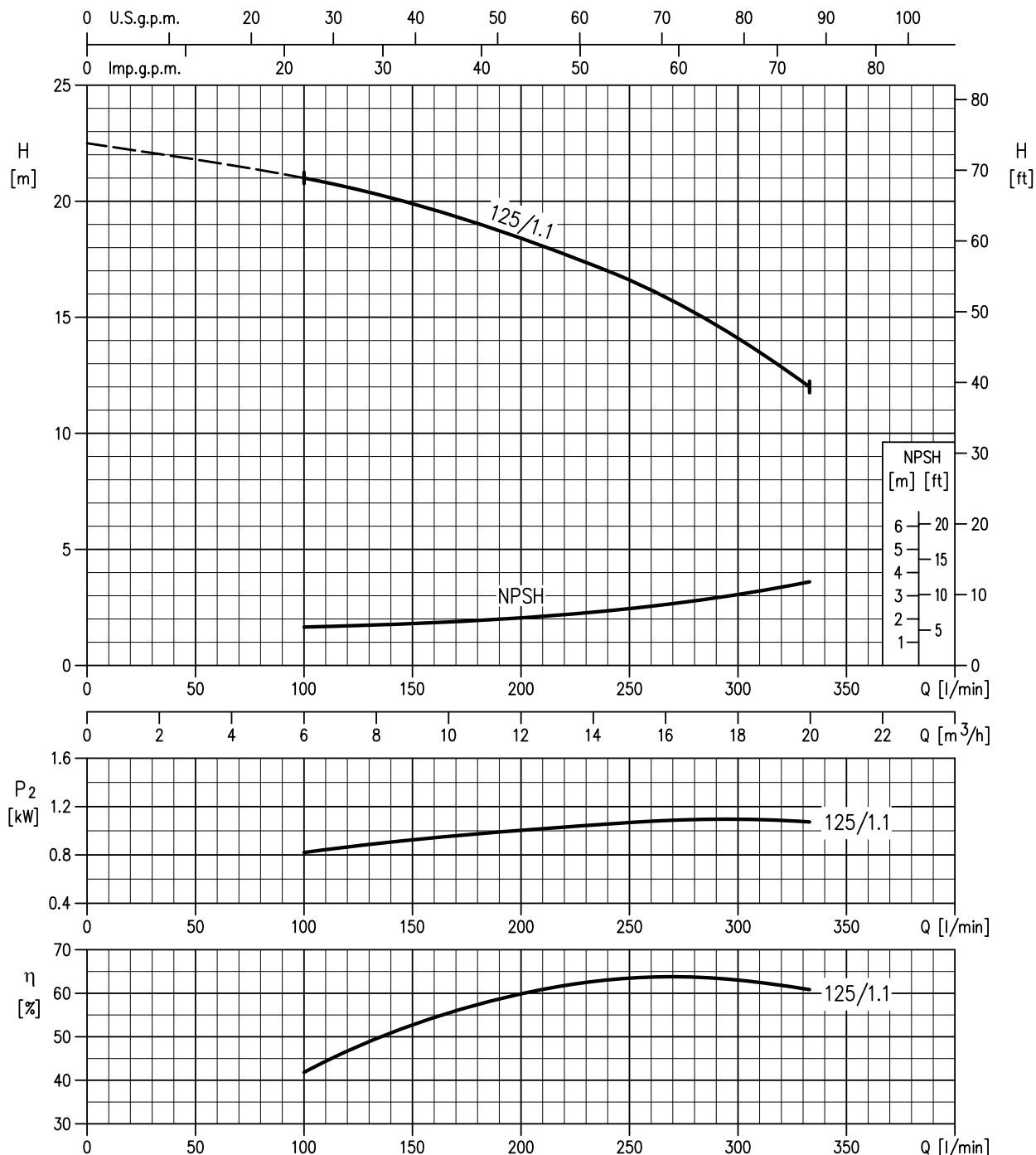

Rotation speed ≈2900 min<sup>-1</sup>  
 Test standard : ISO 9906 Annex A

PERFORMANCE CURVE

50 Hz

Rev. G

3(.)SF 32-160/1.5 and 3(.)PF 32-160/R (1.5kW) – impeller diameter = 151 mm  
 3(.)SF 32-160/2.2 and 3(.)PF 32-160 (2.2kW) – impeller diameter = 166 mm

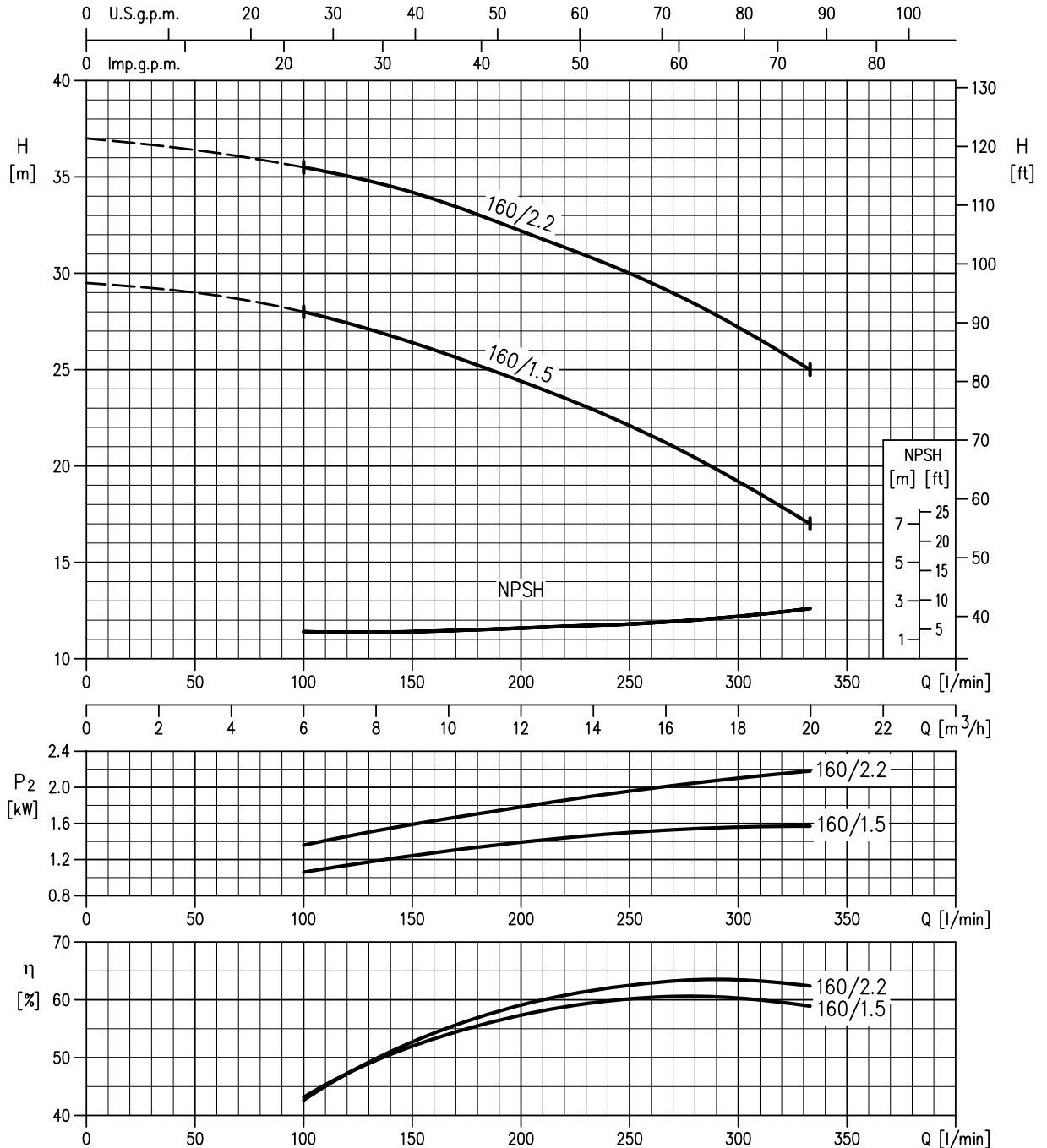

Rotation speed ≈2900 min<sup>-1</sup>  
 Test standard : ISO 9906 Annex A

PERFORMANCE CURVE

50 Hz

Rev. G

3(.)SF 32-200/3 and 3(.)PF 32-200/R (3.0kW) – impeller diameter = 186 mm  
 3(.)SF 32-200/4 and 3(.)PF 32-200 (4.0kW) – impeller diameter = 200 mm  
 3(.)SF 32-200/5.5 and 3(.)PF 32-200/L (5.5kW) – impeller diameter = 224 mm  
 3(.)SF 32-200/7.5 and 3(.)PF 32-200/L (7.5kW) – impeller diameter = 224 mm

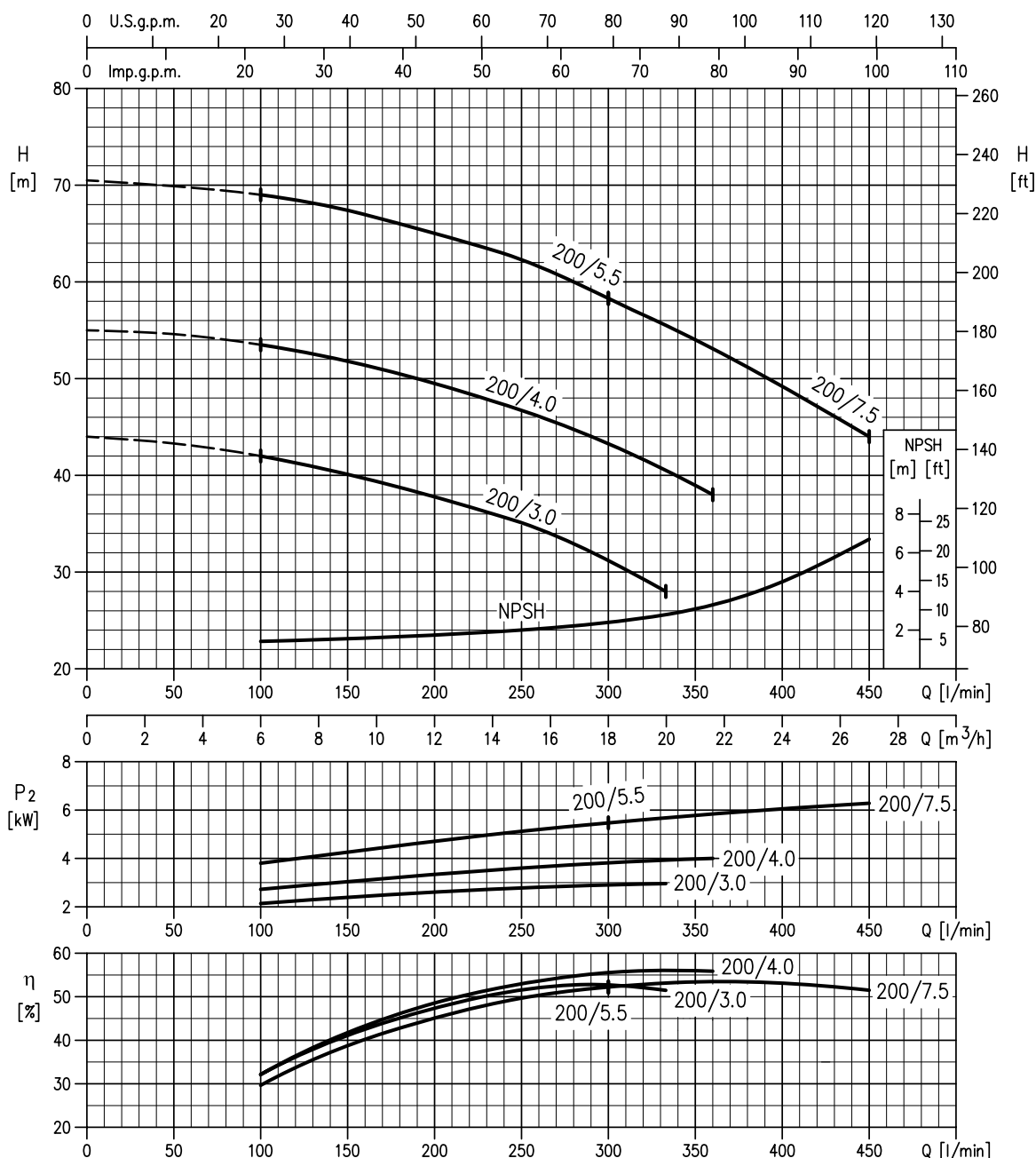

Rotation speed ≈2900 min<sup>-1</sup>  
 Test standard : ISO 9906 Annex A

PERFORMANCE CURVE

50 Hz

Rev. G

3(.)SF 40-125/1.5 and 3(.)PF 40-125/R (1.5kW) – impeller diameter = 125 mm  
 3(.)SF 40-125/2.2 and 3(.)PF 40-125 (2.2kW) – impeller diameter = 140 mm

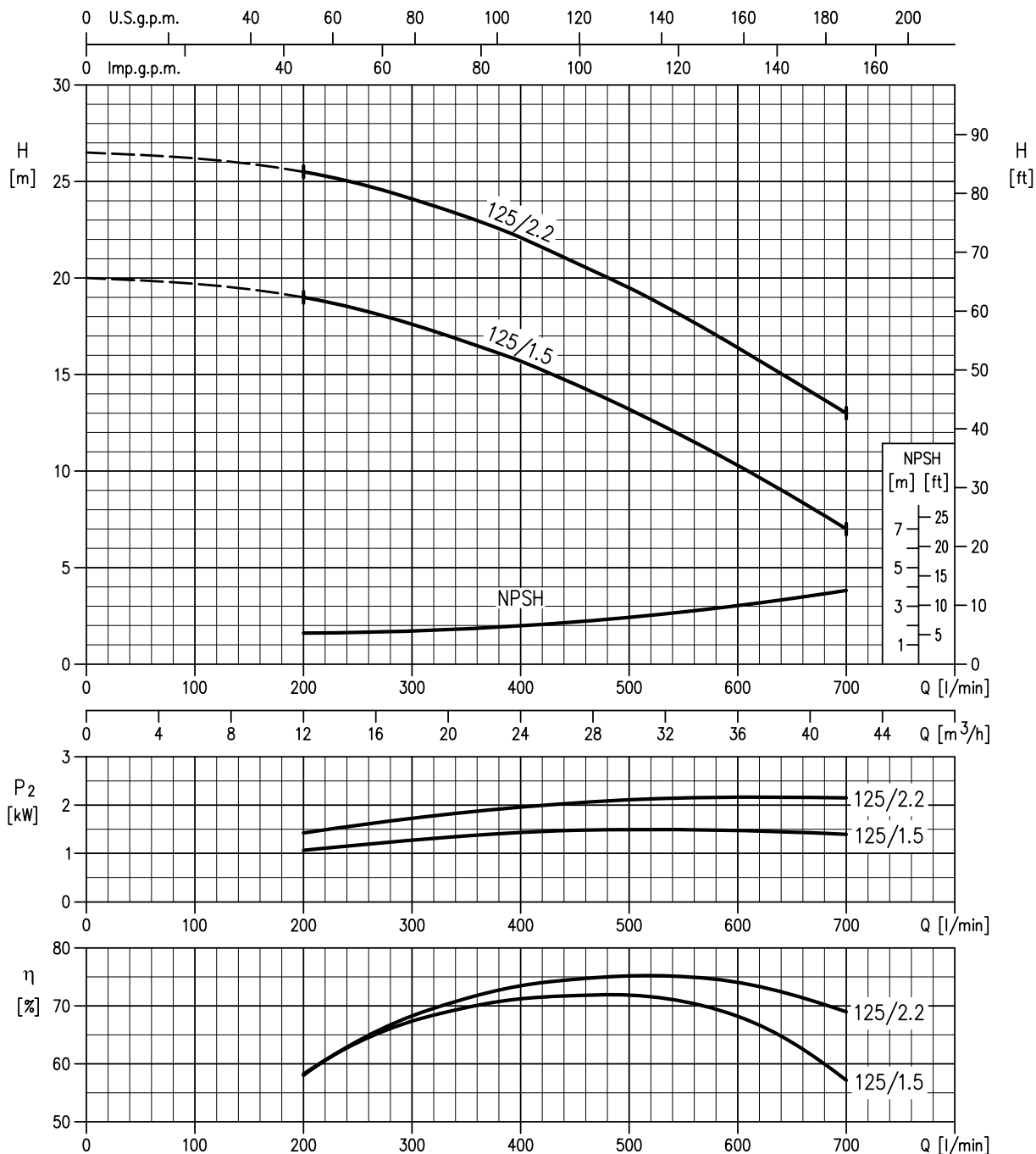

Rotation speed ≈2900 min<sup>-1</sup>  
 Test standard : ISO 9906 Annex A

PERFORMANCE CURVE

50 Hz

Rev. G

3(.)SF 40-160/3 and 3(.)PF 40-160/R (3.0kW).– impeller diameter = 151 mm  
 3(.)SF 40-160/4 and 3(.)PF 40-160 (4.0kW).– impeller diameter = 166 mm

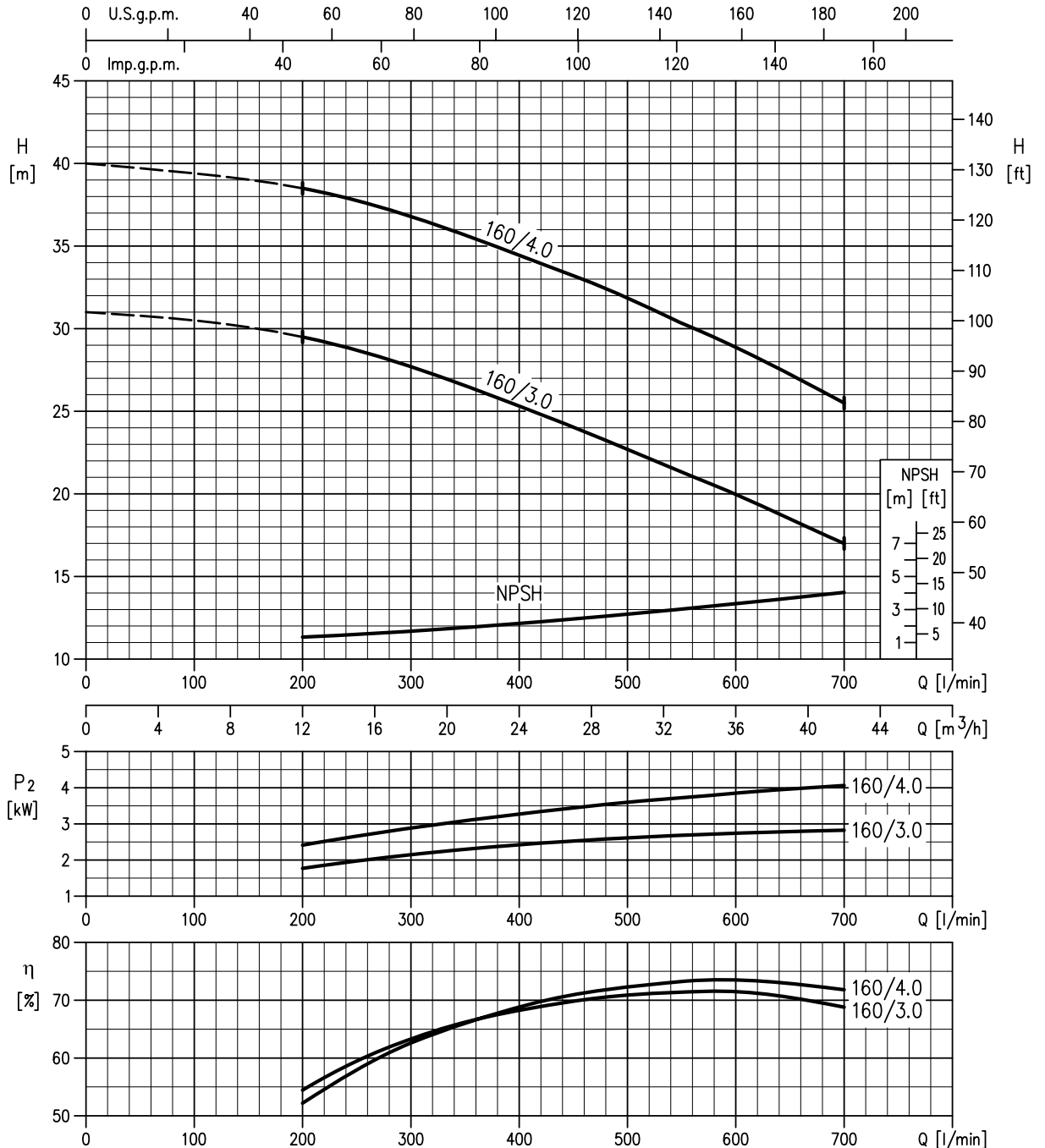

Rotation speed ≈ 2900 min<sup>-1</sup>  
 Test standard : ISO 9906 Annex A

PERFORMANCE CURVE

50 Hz

Rev. G

3(.)SF 40-200/5.5 and 3(.)PF 40-200/R (5.5kW) – impeller diameter = 183 mm  
 3(.)SF 40-200/7.5 and 3(.)PF 40-200 (7.5kW) – impeller diameter = 200 mm  
 3(.)SF 40-200/11 and 3(.)PF 40-200/L (11kW) – impeller diameter = 224 mm

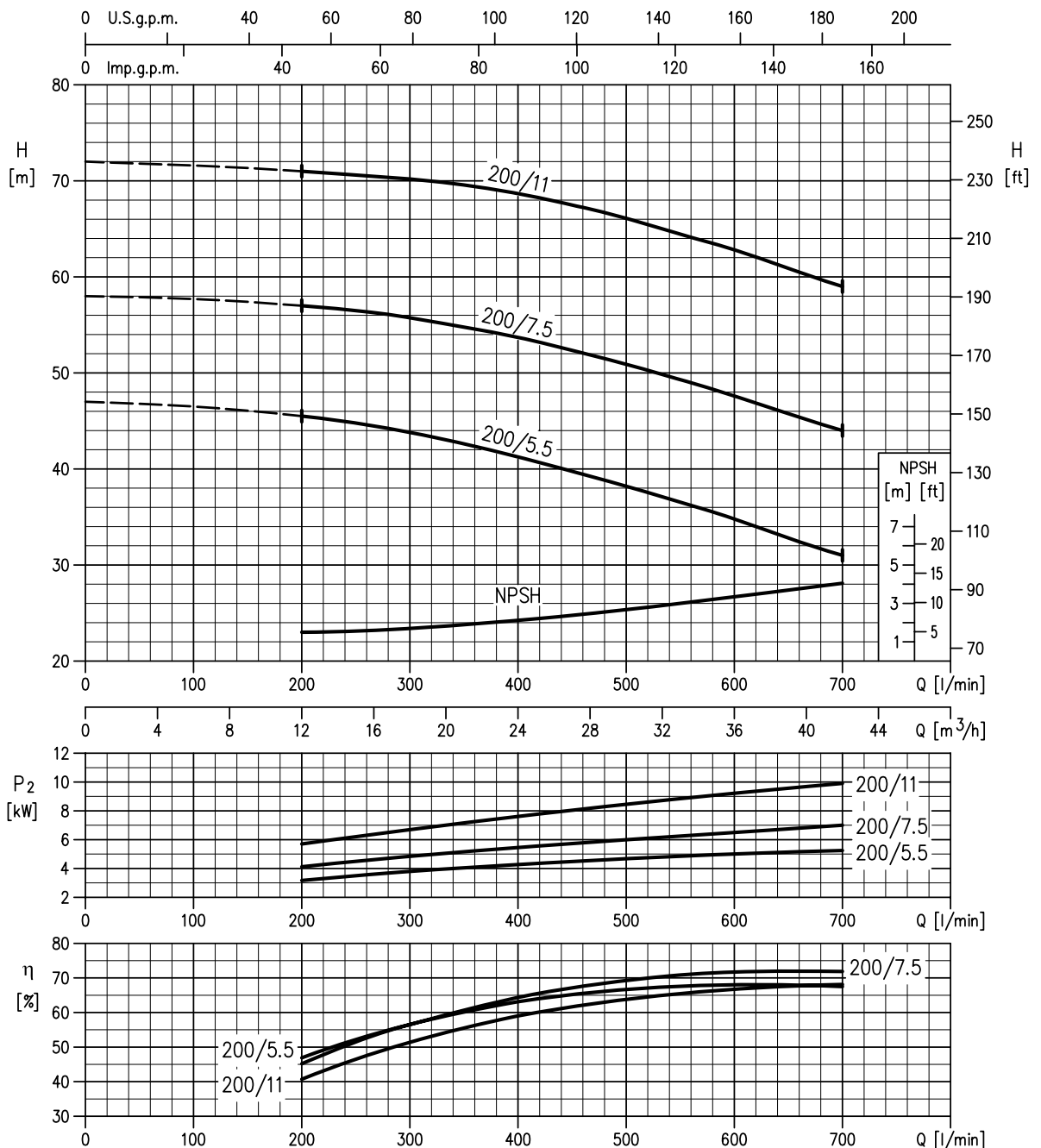

Rotation speed ≈2900 min<sup>-1</sup>  
 Test standard : ISO 9906 Annex A

PERFORMANCE CURVE

50 Hz

Rev. G

3(.)SF 50-125/2.2 and 3(.)PF 50-125/S (2.2kW) – impeller diameter = 126 mm  
 3(.)SF 50-125/3 and 3(.)PF 50-125/R (3.0kW) – impeller diameter = 131 mm  
 3(.)SF 50-125/4 and 3(.)PF 50-125 (4.0kW) – impeller diameter = 140 mm

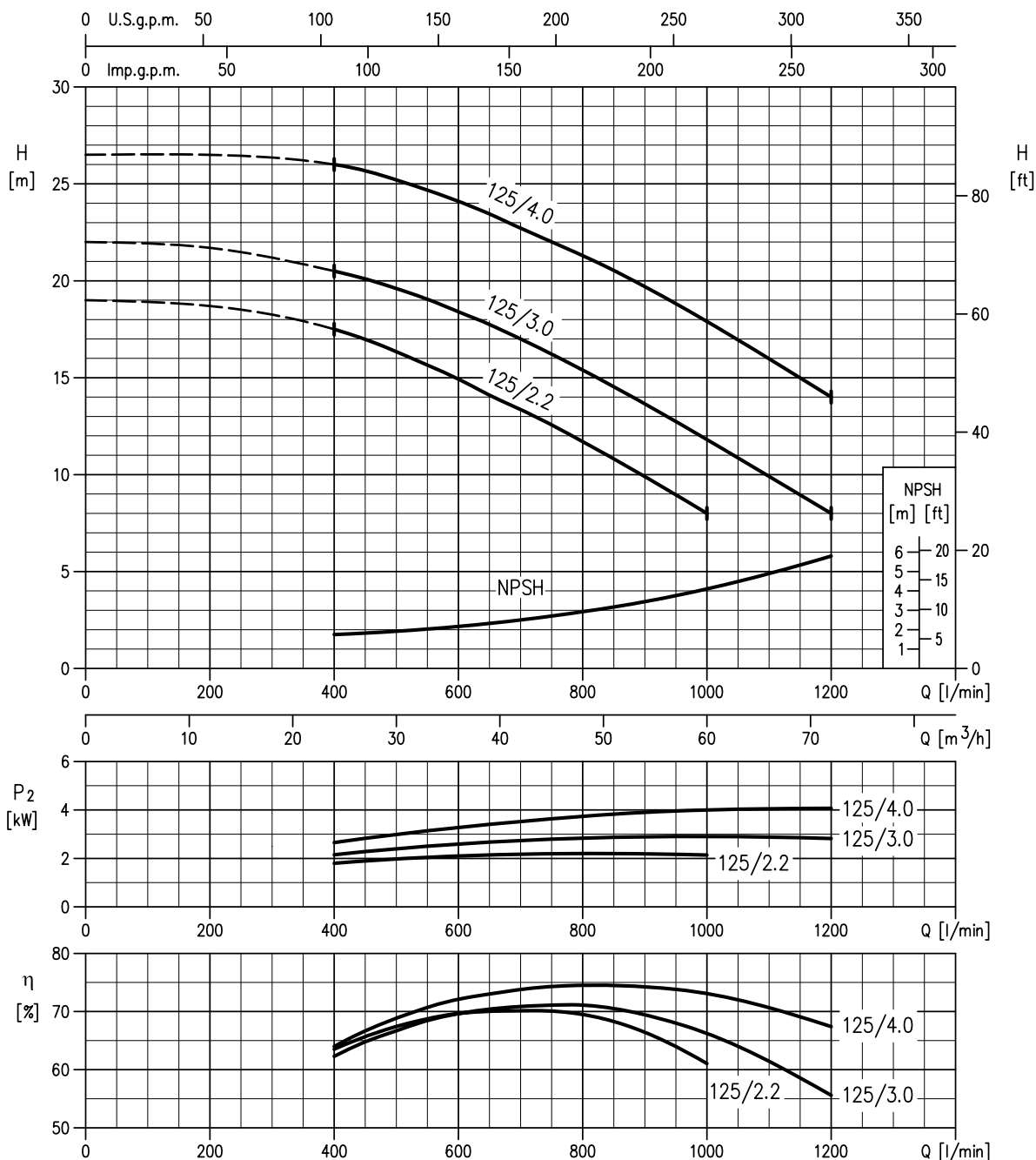

Rotation speed ≈ 2900 min<sup>-1</sup>  
 Test standard : ISO 9906 Annex A

PERFORMANCE CURVE

50 Hz

Rev. G

3(.)SF 50-160/5.5 and 3(.)PF 50-160/R (5.5kW) – impeller diameter = 154 mm  
 3(.)SF 50-160/7.5 and 3(.)PF 50-160 (7.5kW) – impeller diameter = 166 mm

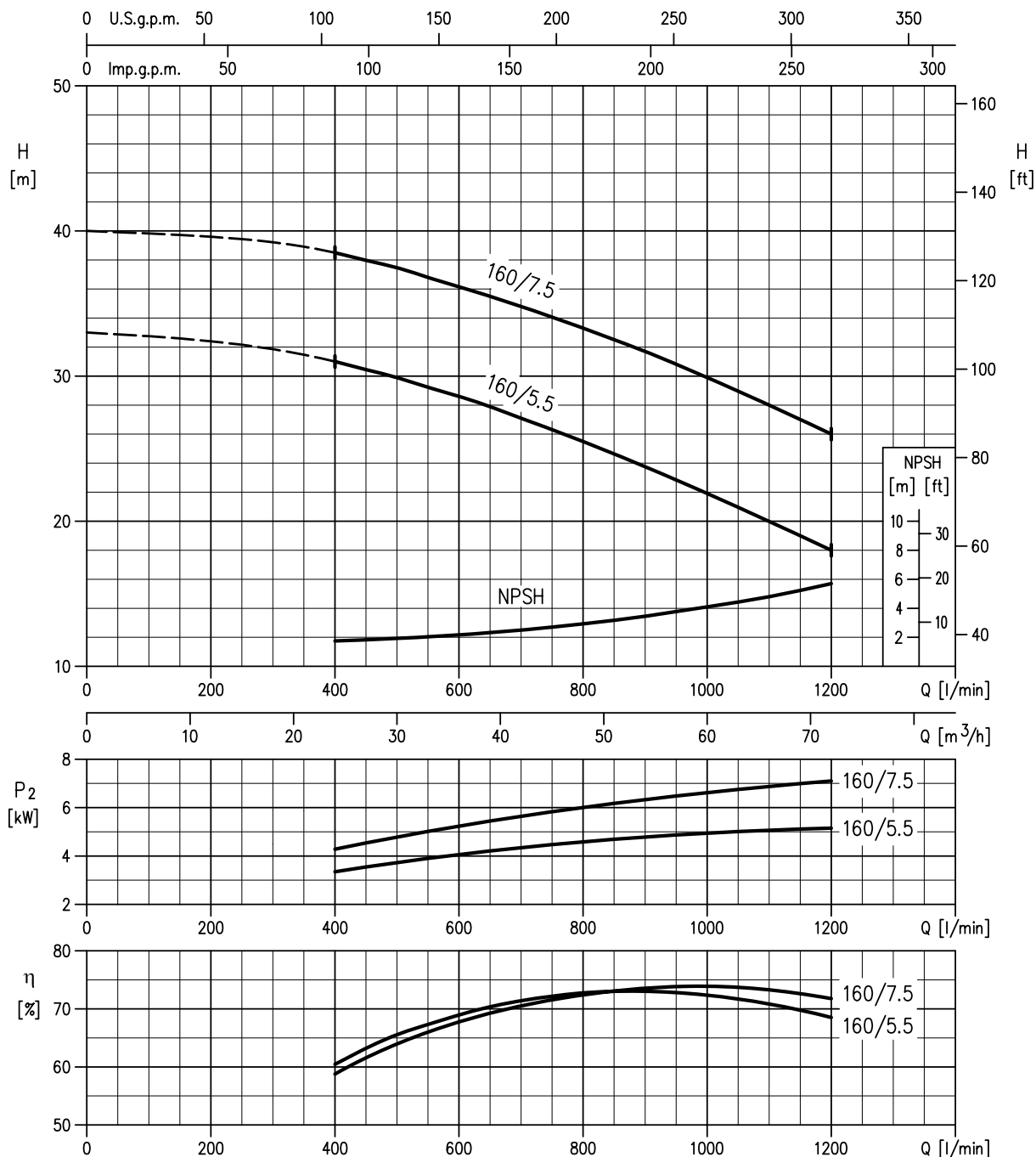

Rotation speed ≈2900 min<sup>-1</sup>  
 Test standard : ISO 9906 Annex A



PERFORMANCE CURVE

50 Hz

Rev. G

3(.)SF 50-200/9.2 and 3(.)PF 50-200/R (9.2kW) – impeller diameter = 191 mm  
 3(.)SF 50-200/11 and 3(.)PF 50-200 (11kW) – impeller diameter = 200 mm  
 3(.)SF 50-200/15 and 3(.)PF 50-200/L (15kW) – impeller diameter = 224 mm

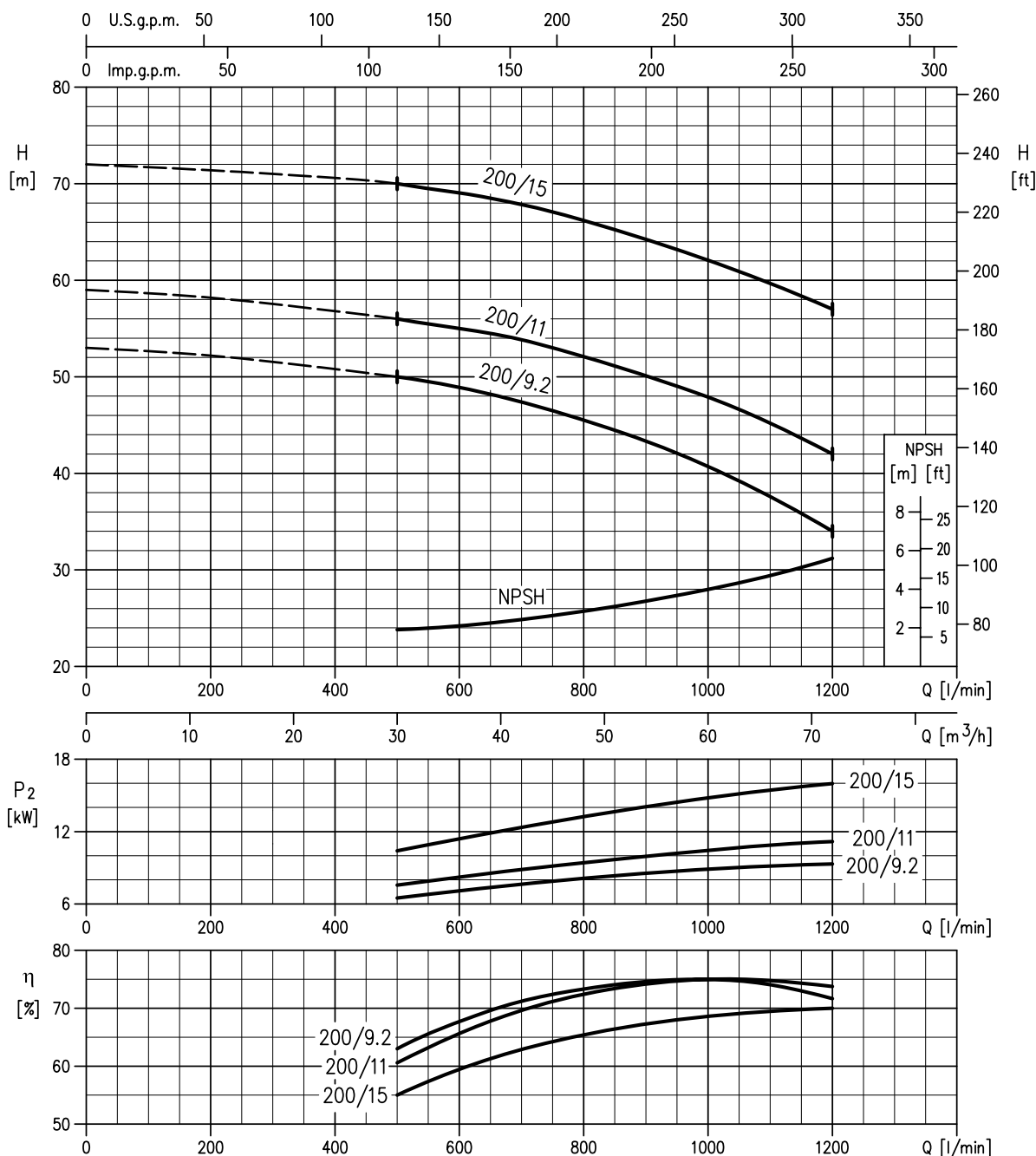

Rotation speed ≈ 2900 min<sup>-1</sup>  
 Test standard : ISO 9906 Annex A

PERFORMANCE CURVE

50 Hz

Rev. G

3(.)SF 65-125/4 and 3(.)PF 65-125/R (4.0kW) – impeller diameter = 128 mm  
 3(.)SF 65-125/5.5 and 3(.)PF 65-125 (5.5kW) – impeller diameter = 138 mm  
 3(.)SF 65-125/7.5 and 3(.)PF 65-125/L (7.5kW) – impeller diameter = 149 mm

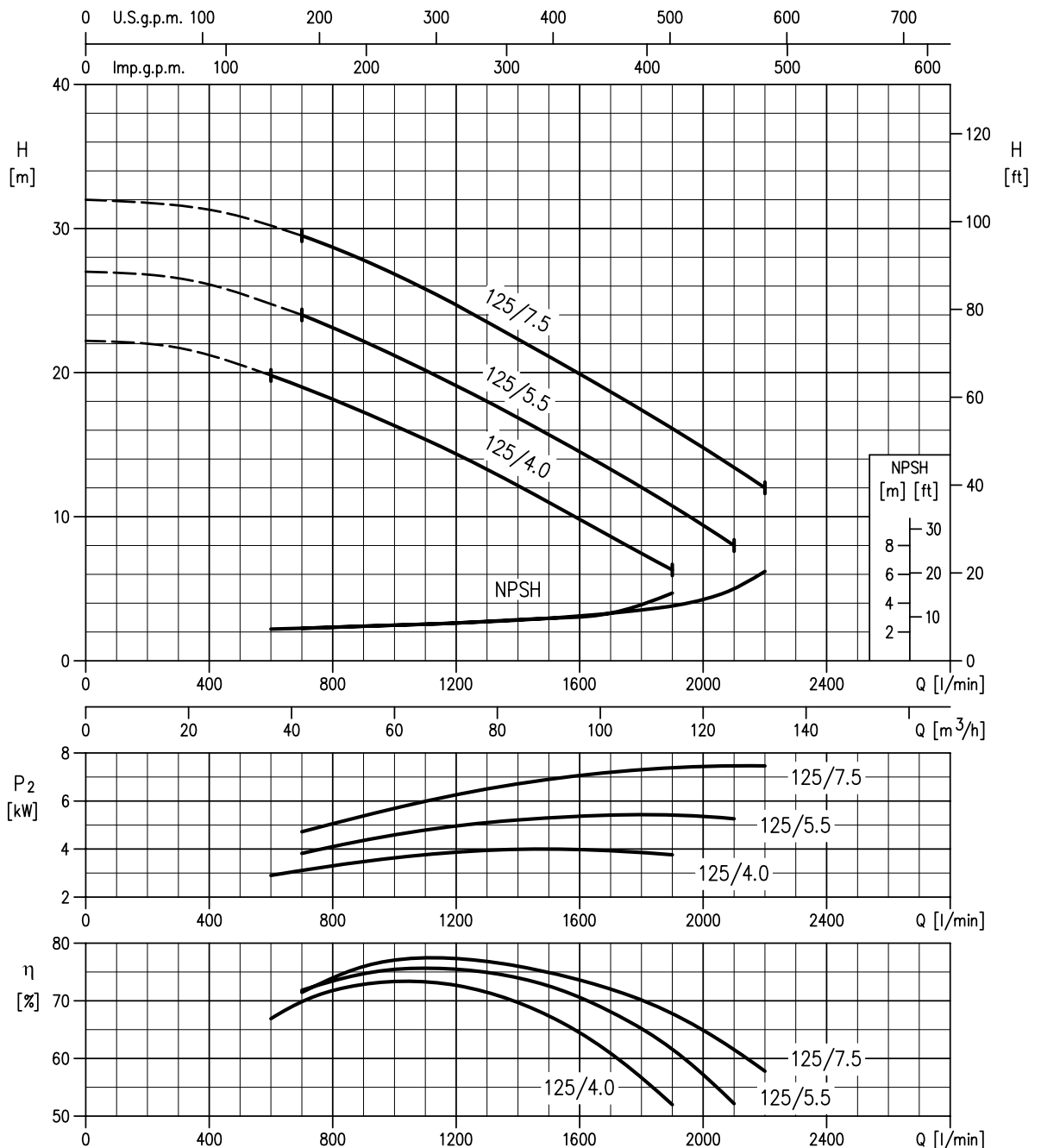

Rotation speed ≈ 2900 min<sup>-1</sup>  
 Test standard : ISO 9906 Annex A

PERFORMANCE CURVE

50 Hz

Rev. G

3(.)SF 65-160/7.5 and 3(.)PF 65-160/S (7.5kW) – impeller diameter = 153 mm  
 3(.)SF 65-160/9.2 and 3(.)PF 65-160/R (9.2kW) – impeller diameter = 161 mm  
 3(.)SF 65-160/11 and 3(.)PF 65-160 (11kW) – impeller diameter = 168 mm  
 3(.)SF 65-160/15 and 3(.)PF 65-160/L (15kW) – impeller diameter = 178 mm

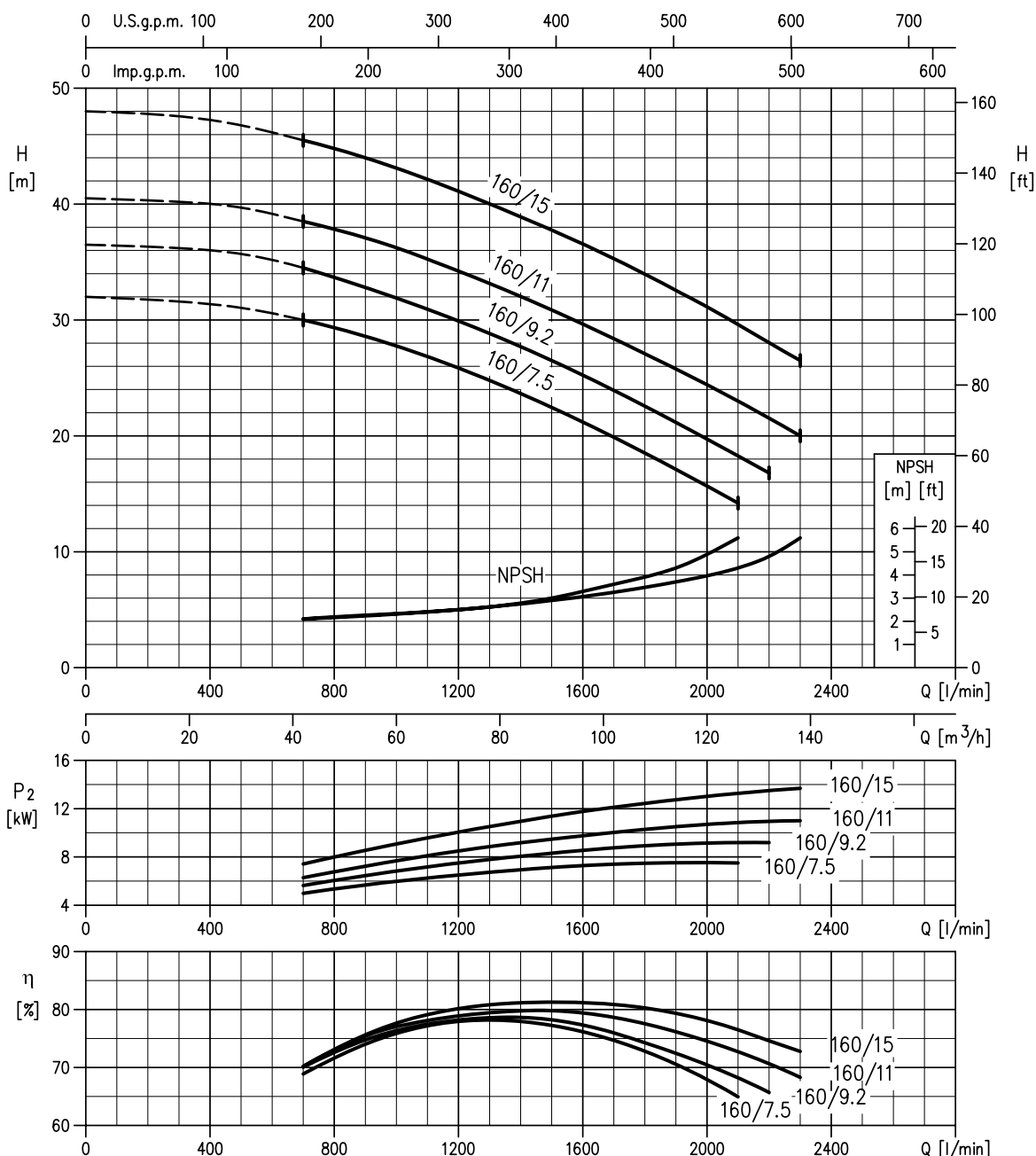

Rotation speed ≈2900 min<sup>-1</sup>  
 Test standard : ISO 9906 Annex A

PERFORMANCE CURVE

50 Hz

Rev. G

3(.)SF 65-200/15 and 3(.)PF 65-200/R (15kW) – impeller diameter = 190 mm  
 3(.)SF 65-200/18.5 and 3(.)PF 65-200 (18.5kW) – impeller diameter = 201 mm  
 3(.)SF 65-200/22 and 3(.)PF 65-200/L (22kW) – impeller diameter = 212 mm

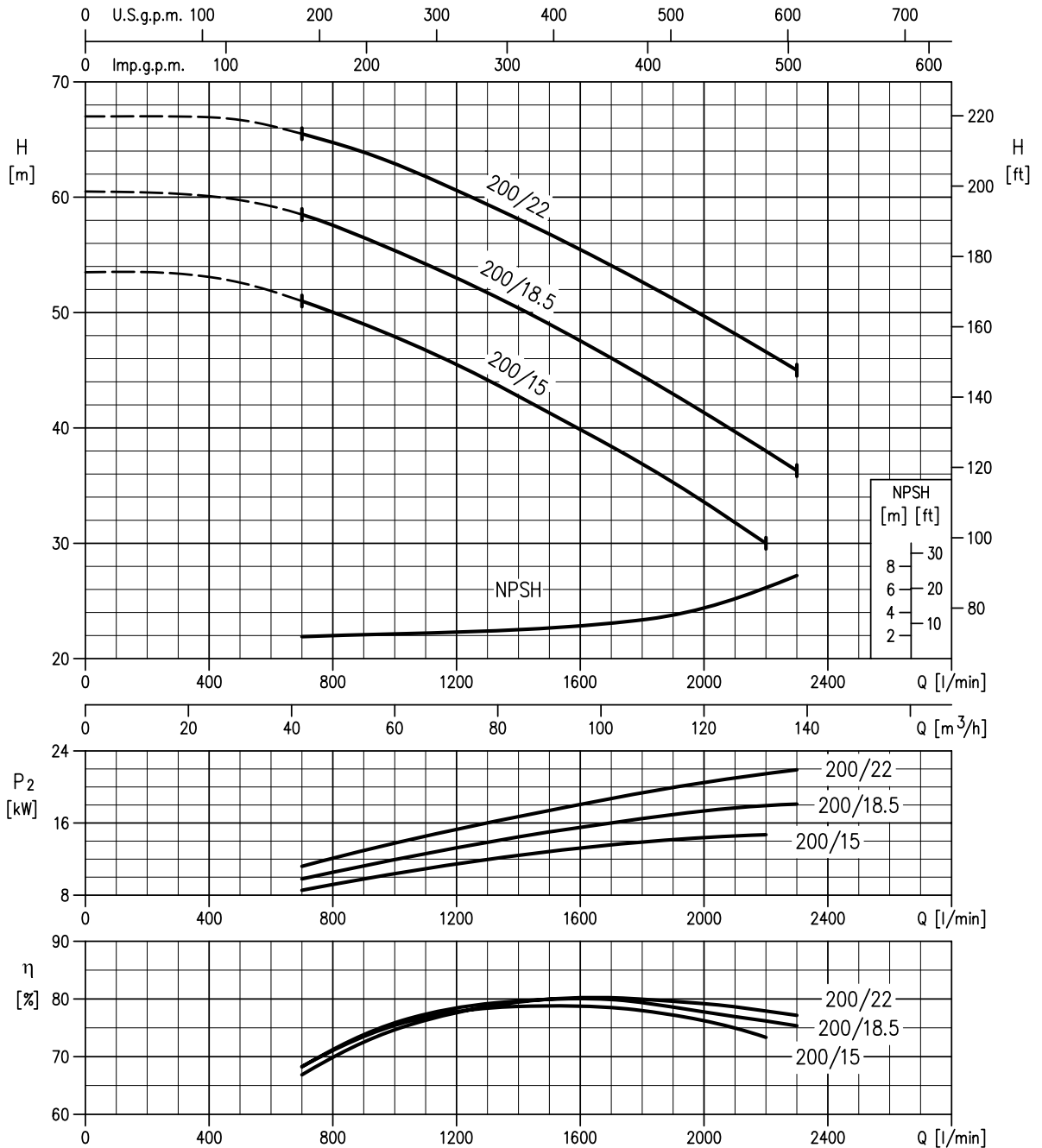

Rotation speed ≈ 2900 min<sup>-1</sup>  
 Test standard : ISO 9906 Annex A

PERFORMANCE CURVE

50 Hz

Rev. G

3LSF 65-250/30 and 3LPF 65-250 (30kW) – impeller diameter = 235 mm  
 3LSF 65-250/37 and 3LPF 65-250/L (37kW) – impeller diameter = 250 mm

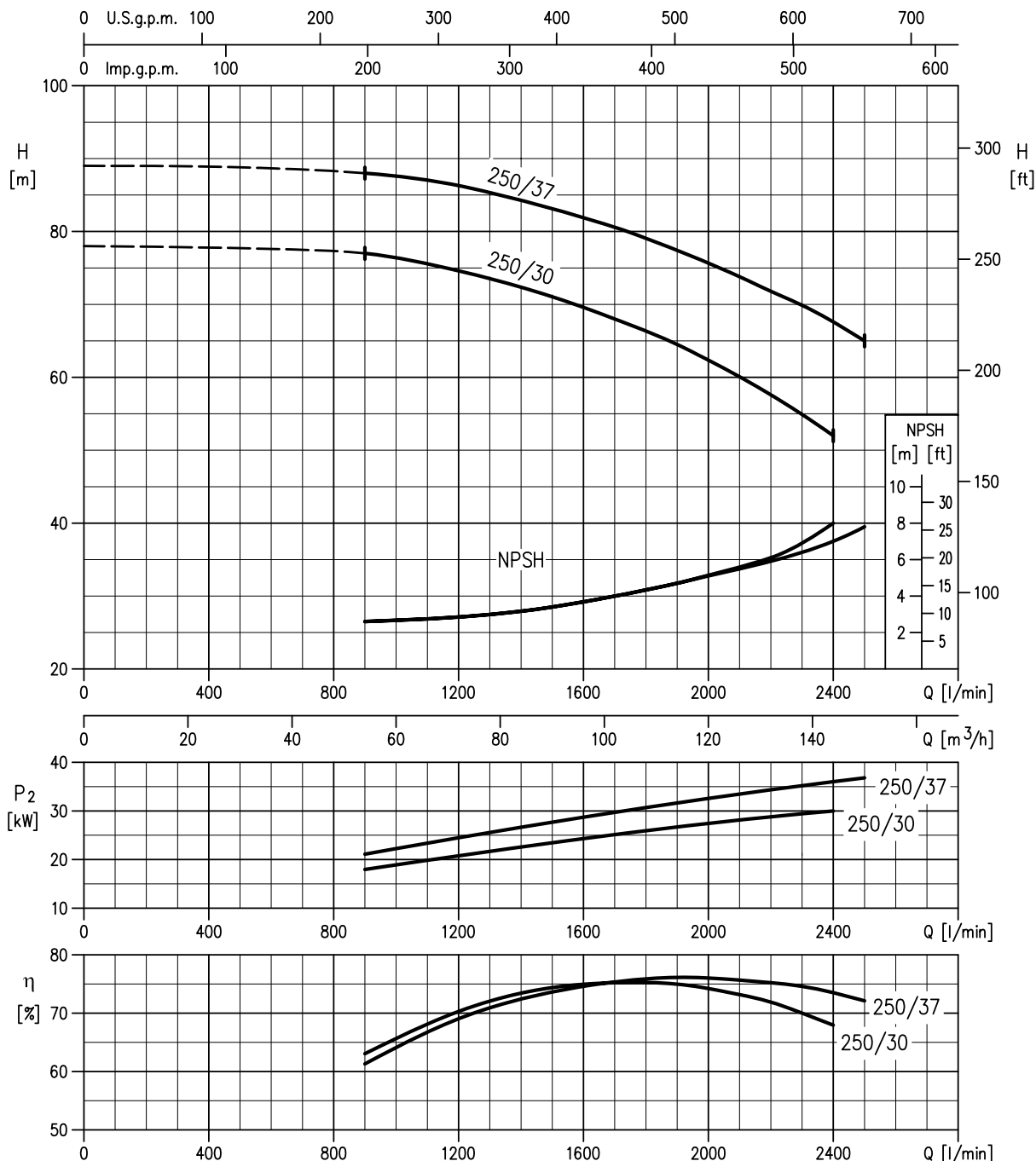

Rotation speed ≈2900 min<sup>-1</sup>  
 Test standard : ISO 9906 Annex A

PERFORMANCE CURVE

50 Hz

Rev. G

**3LSF 80-160/11** and **3LPF 80-160/S** (11kW) – impeller diameter = 154 mm  
**3LSF 80-160/15R** and **3LPF 80-160/R** (15kW) – impeller diameter = 160 mm  
**3LSF 80-160/15** and **3LPF 80-160** (15kW) – impeller diameter = 165 mm  
**3LSF 80-160/18.5** and **3LPF 80-160/L** (18.5kW) – impeller diameter = 174 mm

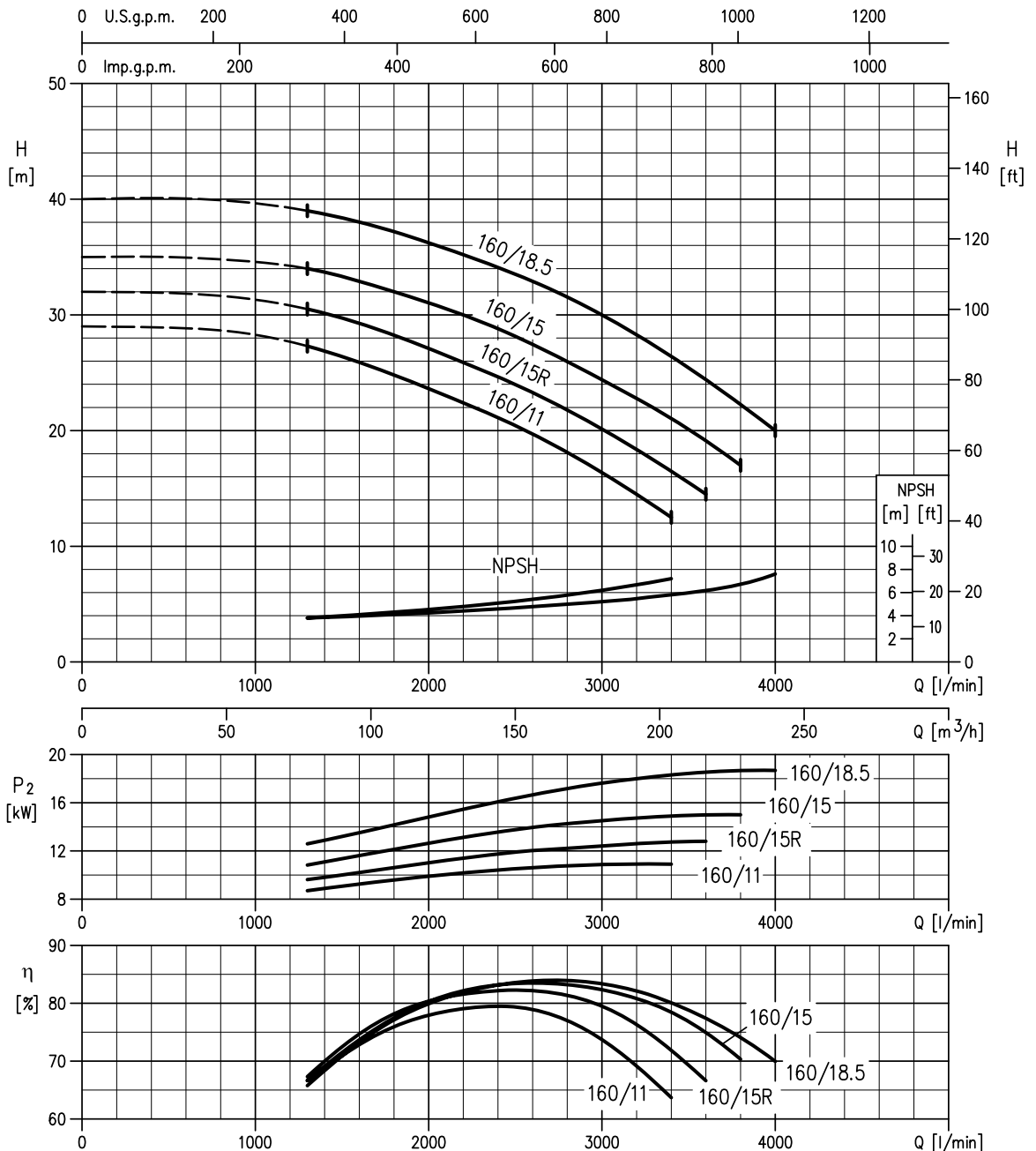

Rotation speed ≈ 2900 min<sup>-1</sup>  
 Test standard : ISO 9906 Annex A

PERFORMANCE CURVE

50 Hz

Rev. G

3LSF 80-200/22 and 3LPF 80-200/R (22kW) – impeller diameter = 196 mm  
 3LSF 80-200/30 and 3LPF 80-200 (30kW) – impeller diameter = 211 mm  
 3LSF 80-200/37 and 3LPF 80-200/L (37kW) – impeller diameter = 219 mm

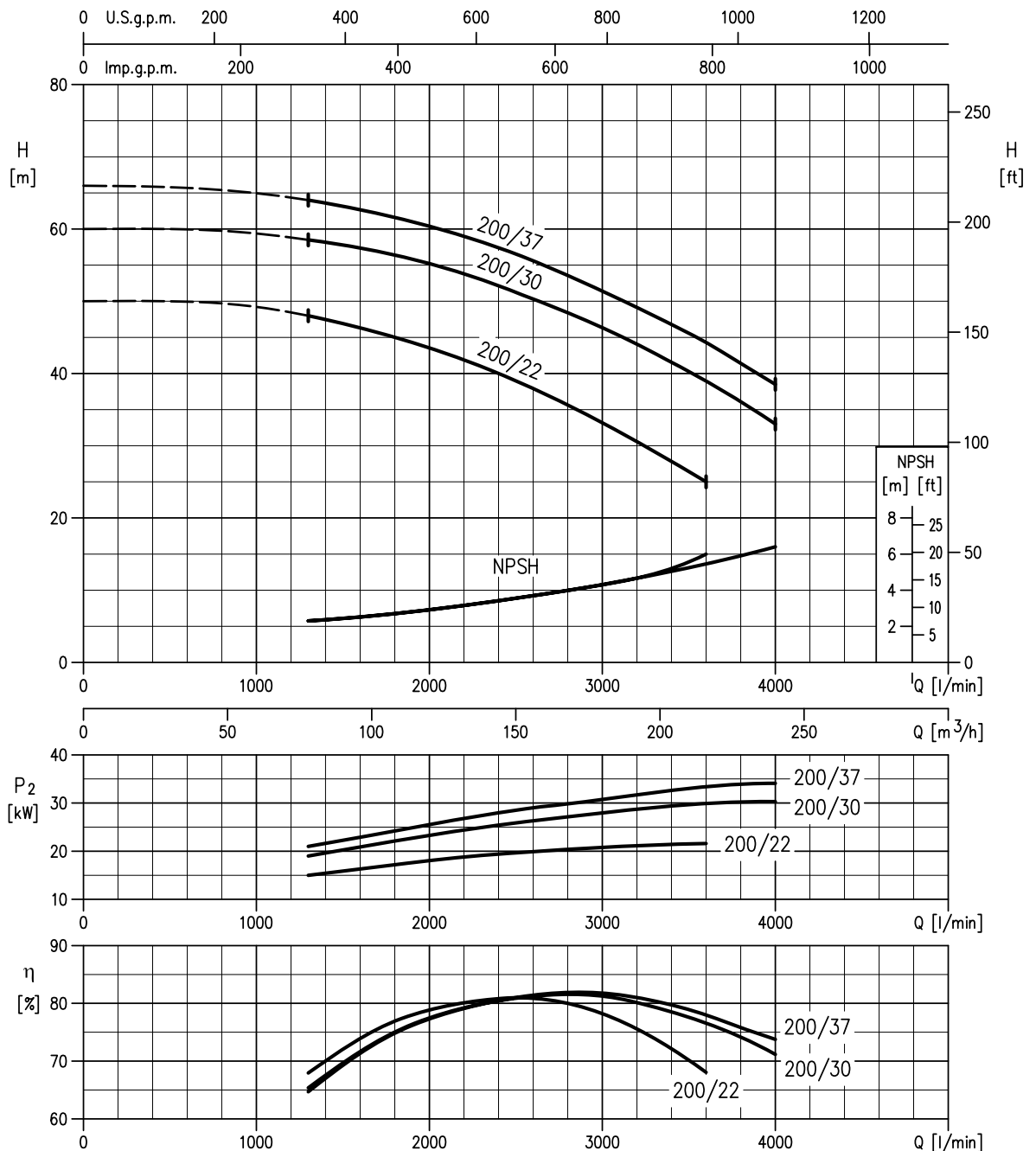

Rotation speed ≈ 2900 min<sup>-1</sup>  
 Test standard : ISO 9906 Annex A

PERFORMANCE CURVE

50 Hz

Rev. G

3LSF 80-250/37 and 3LPF 80-250/R (37kW) – impeller diameter = 230 mm  
 3LSF 80-250/45 and 3LPF 80-250 (45kW) – impeller diameter = 245 mm  
 3LSF 80-250/55 and 3LPF 80-250/L (55kW) – impeller diameter = 259 mm

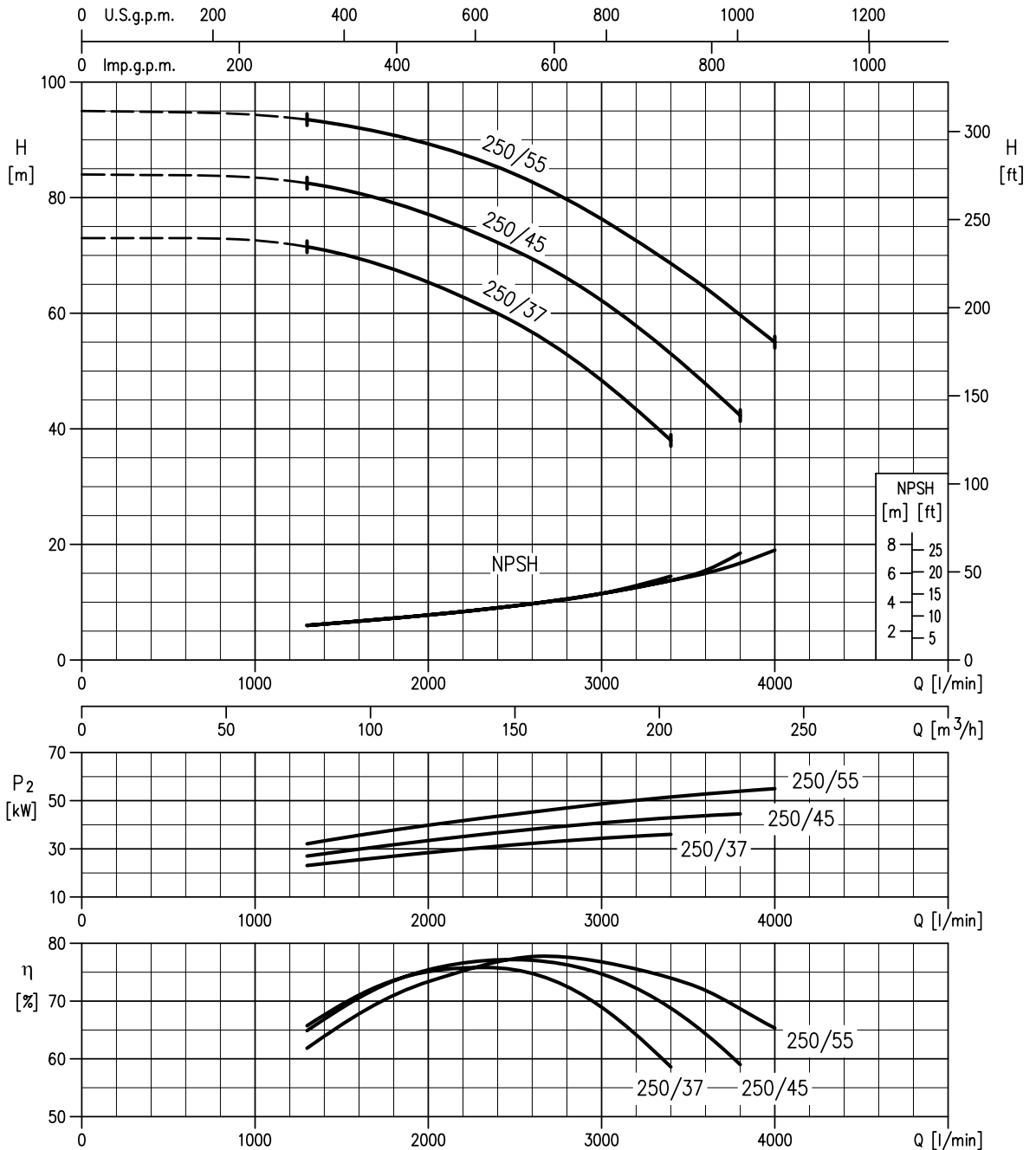

Rotation speed ≈2900 min<sup>-1</sup>  
 Test standard : ISO 9906 Annex A



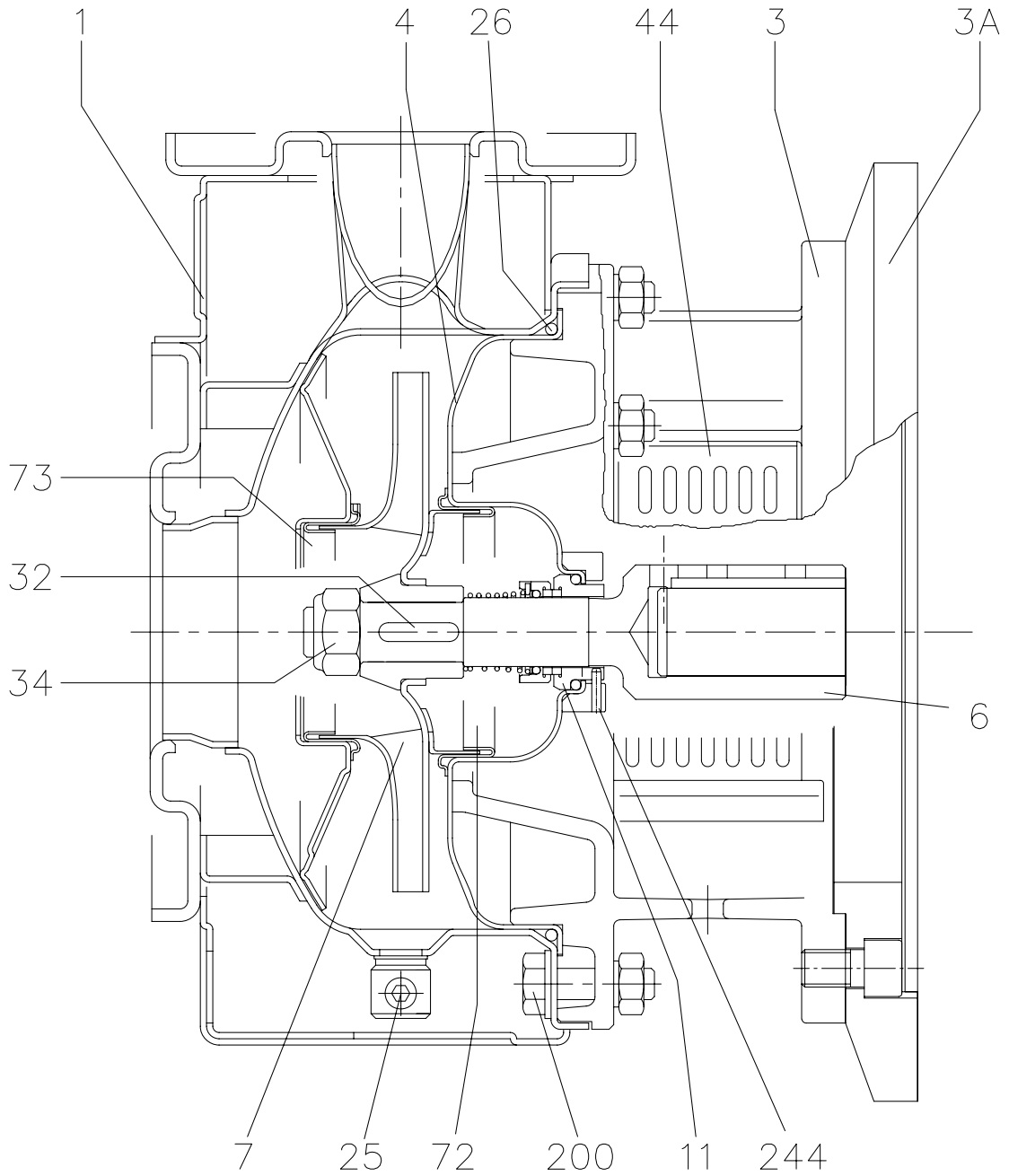

N°	PART NAME	MATERIAL		DIMENSIONS	STANDARD	N. FOR 1 UNIT	
		3SF	3LSF				
001	Casing	EN 1.4301 (AISI 304)	EN 1.4404 (AISI 316L)			1	
003	Motor bracket	Cast iron EN-GJL-200-EN 1561				1	
003A	Adapter ring [1]	Cast iron EN-GJL-200-EN 1561				1	
004	Casing cover	EN 1.4301 (AISI 304)	EN 1.4404 (AISI 316L)			1	
006	Coupling - Part in contact with liquid	EN 1.4301 (AISI 304)	EN 1.4404 (AISI 316L)	See table p. 318		1	
007	Impeller	32,40,50 65-125/160/200	EN 1.4301 (AISI 304) EN 1.4404 (AISI 316L)			1	
011	Mechanical seal	Carbon/Ceramic/NBR Carbon/Ceramic/FPM (H option) SiC/SiC/FPM (HS option)	EN 1.4401 (AISI 316) SiC/SiC/FPM	See p. 313-317		1	
025	Draining plug	EN 1.4401 (AISI 316) / PTFE		R 1/8" L=8	DIN 906	1	
026	"O" ring	32-125, 40-125 32-160, 40-160, 50-125, 65-125 32-200, 40-200, 50-160, 50-200, 65-160, 65-200	NBR FPM (version H and HS)	FPM	158.11x5.34	OR 6625	1
					183.52x5.34	OR 6720	
					227.96x5.34	OR 6895	
032	Key	Up to 11 kW 15 kW and above	EN 1.4301 (AISI 304)	EN 1.4401 (AISI 316)	6x6x25 8x7x30	UNI 6604	1
034	Impeller nut	Up to 11kW 50-200/15 15 kW and above	EN 1.4301 (AISI 304)	EN 1.4404 (AISI 316L)	M16x1.5	UNI 7474	1
					M18x1.5 M20x1.5		
044	Protection	EN 1.4301 (AISI 304)			EBARA DRAWING	1	
072	Casing ring [2]	EN 1.4301 (AISI 304)	EN 1.4404 (AISI 316L)			1	
073	Casing ring (not for 65 version)	EN 1.4301 (AISI 304)	EN 1.4404 (AISI 316L)			1	
200	Screw	32-125, 40-125 40-160, 40-200, 50-125, 50-160, 50-200, 65-125, 65-160, 65-200	Stainless steel A2 70 class ISO 3506/1		M 8x30	UNI 5739	8
					M 10x35	UNI 5739	[3]
244	Pin [4]	/	EN 1.4301 (AISI 304)	4x15		1	

Counterflange kit on request, see table p.319-320

[1] Only for 65-125/5.5 and 65-125/7.5

[2] For version 32-200, 40-200, 50-160, 50-200

[3] N° for 1 unit=10 for 32-160, 40-160, 50-125, 65-125

N° for 1 unit=12 for 32-200, 40-200, 50-160, 50-200, 65-160, 65-200

[4] Only for 65-160/15 and 65-200

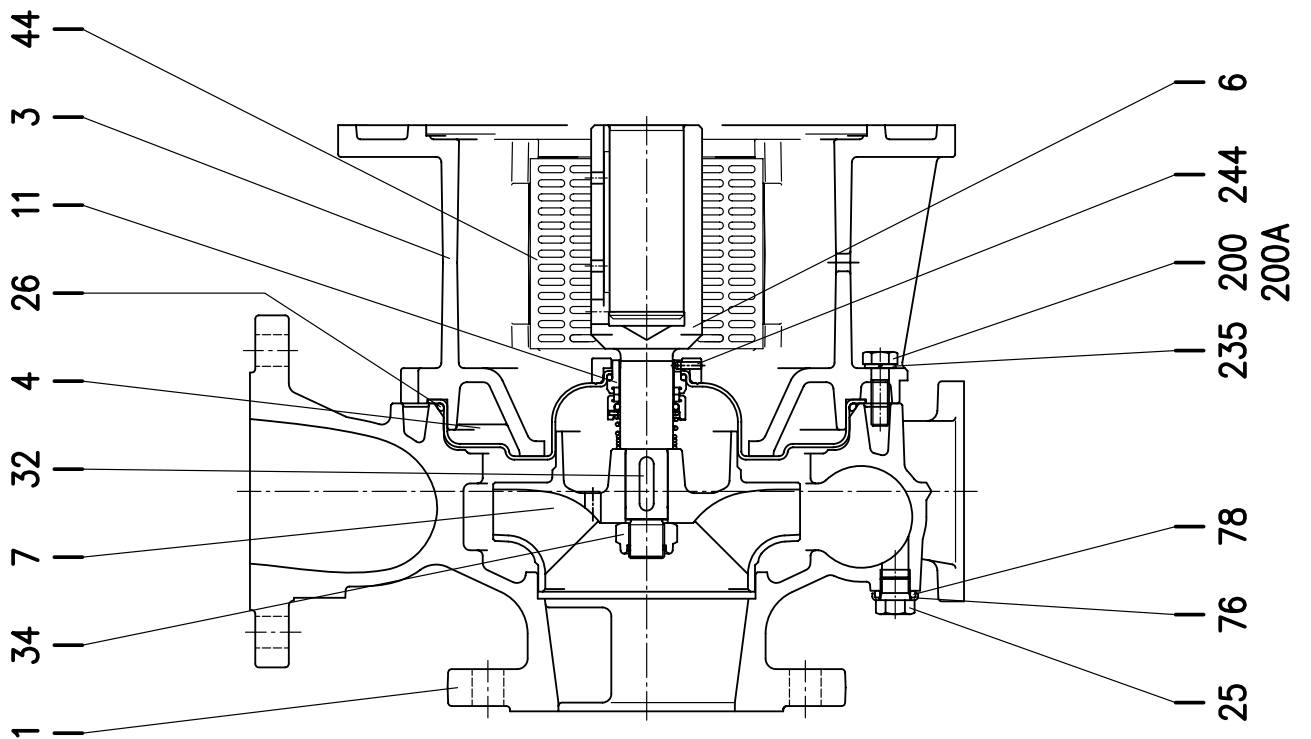
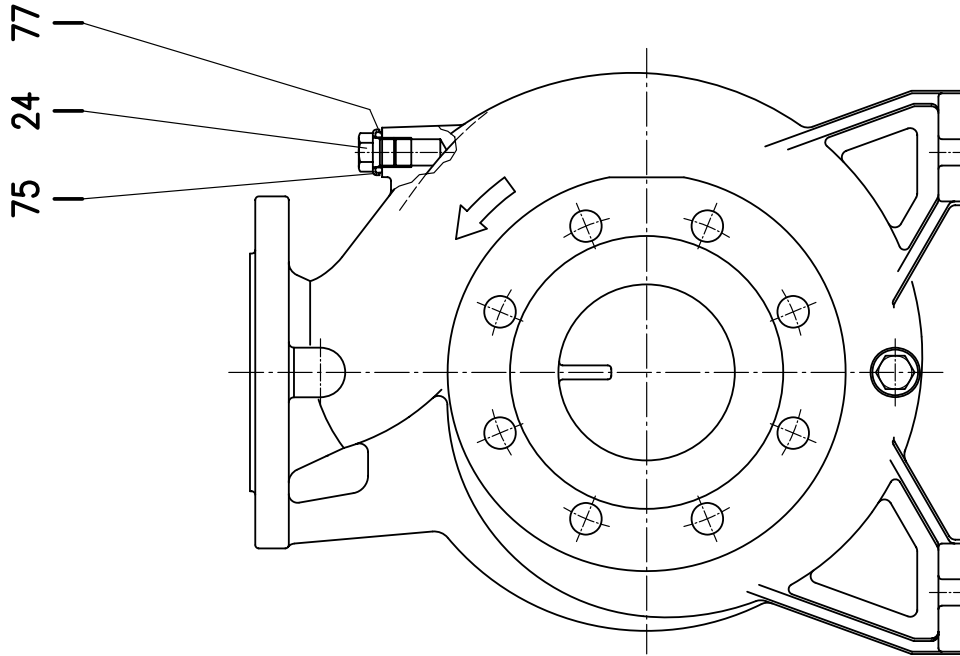

N°	PART NAME	MATERIAL	DIMENSIONS	STANDARD	N. FOR 1 UNIT
001	Casing	EN 1.4401 (AISI 316)			1
003	Motor bracket	Cast iron EN-GJL-200-EN 1561			1
004	Casing cover	EN 1.4404 (AISI 316L)			1
006	Coupling	EN 1.4404 (AISI 316L)	See table p. 318		1
007	Impeller	EN 1.4401 (AISI 316)			1
011	Mechanical seal	SiC/SiC/FPM Ceramic/Carbon/FPM (H option) SiC/Carbon/EPDM (E option)	See p. 313-317		1
024	Plug	EN 1.4404 (AISI 316L)	G3/8	EPE DRAWING	1
025	Plug	EN 1.4404 (AISI 316L)	G3/8	EPE DRAWING	1
026	"O" ring	FPM EPDM (E option)	227.96x5.34	OR 6895	1
032	Key	EN 1.4401 (AISI 316)	8x7x30	UNI 6604	1
034	Impeller nut	EN 1.4404 (AISI 316L)	M20x1.5	UNI 7474	1
044	Protection	EN 1.4301 (AISI 304)		EPE DRAWING	2
075	Washer (plug)	EN 1.4404 (AISI 316L)			1
076	Washer (plug)				1
077	O-ring (plug)	FPM EPDM (E option)			1
078	O-ring (plug)				1
200	Screw	Stainless steel A2-70 class ISO 3506/1	M 10x35	UNI 5739	10
200A	Screw		M 10x30		2
235	Washer	EN 1.4301(AISI 304)	10.5	UNI 8842	12
244	Pin [1]	EN 1.4301(AISI 304)	4x15		1

Counterflange kit on request see p. 319-320

[1] Not for H and E option

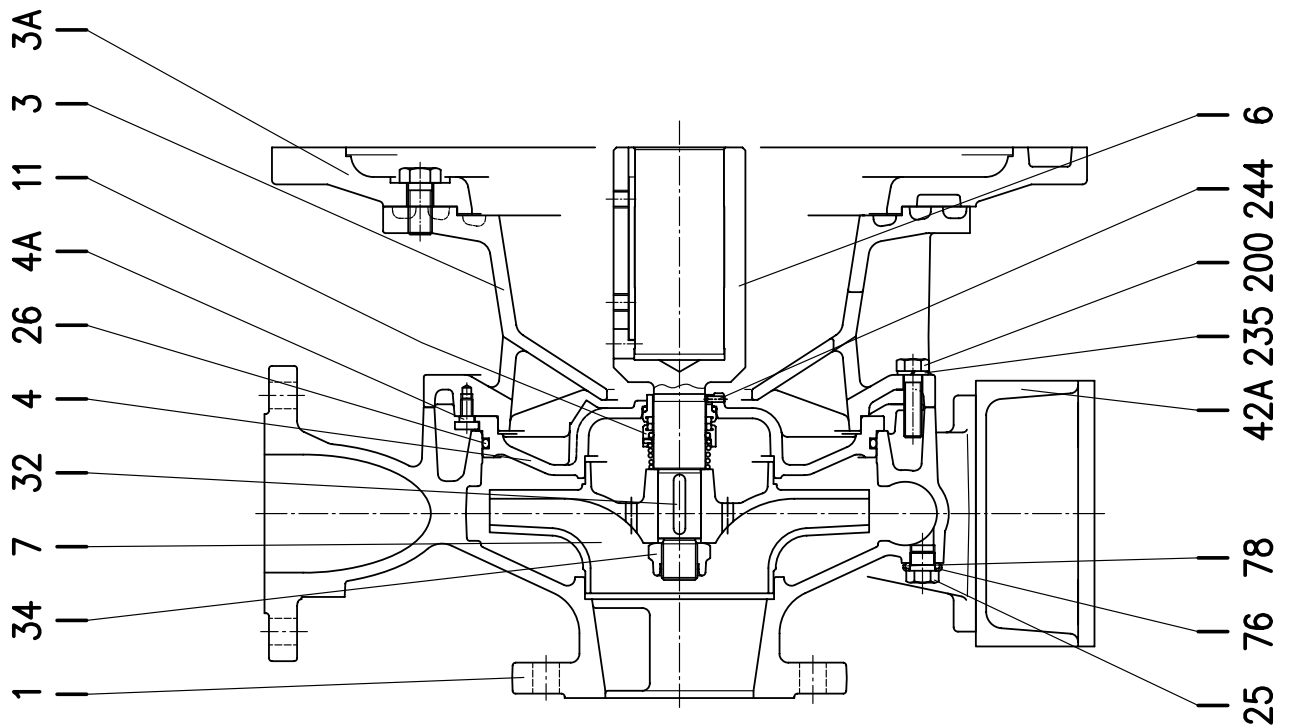
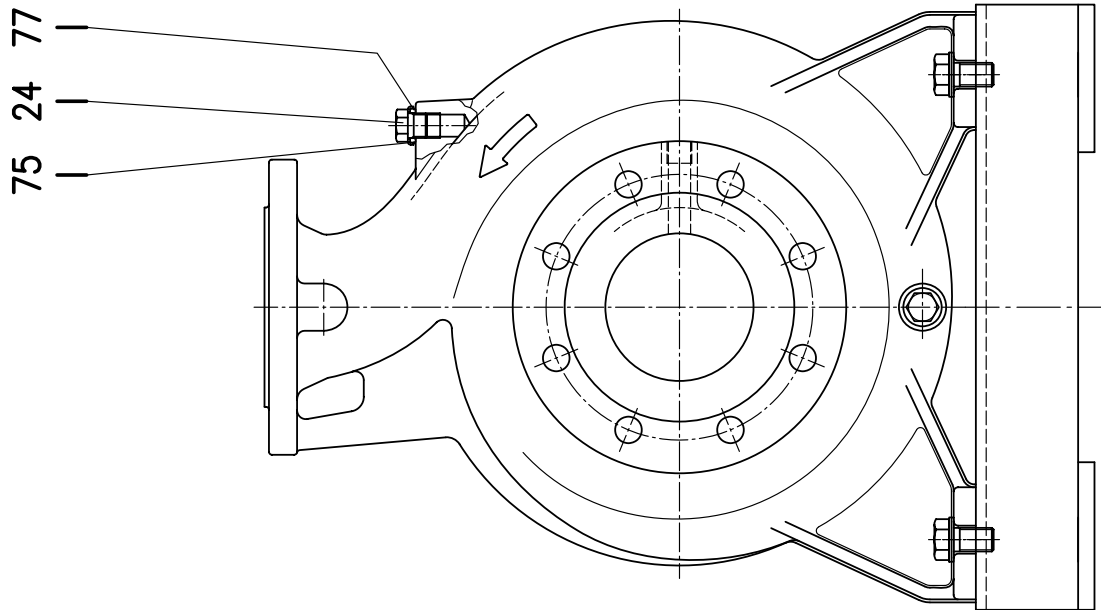

N°	PART NAME		MATERIAL	DIMENSIONS	STANDARD	N. FOR 1 UNIT
001	Casing		EN 1.4401 (AISI 316)			1
003	Motor bracket		Cast iron EN-GJL-200-EN 1561			1
003A	Adapter ring		Cast iron EN-GJL-200-EN 1561			[1]
004	Casing cover		EN 1.4401 (AISI 316)			1
004A	Screw for casing cover		EN 1.4301(AISI 304)			2
006	Coupling	65-250	d=24 mm	EN 1.4462 (Duplex stainless steel)		1
		80-200	d=24 mm	EN 1.4404 (AISI 316L) for 22 kW		
		80-250	d=29 mm	EN 1.4462 (Duplex stainless steel) for 30-37 kW		
007	Impeller		EN 1.4401 (AISI 316)			1
011	Mechanical seal		SiC/SiC/FPM Ceramic/Carbon/FPM (H option) SiC/Carbon/EPDM (E option)	See p. 313-317		1
024	Plug		EN 1.4404 (AISI 316L)	G3/8	EPE DRAWING	1
025	Plug		EN 1.4404 (AISI 316L)	G3/8	EPE DRAWING	1
026	"O" ring		FPM EPDM (E version)	253.36x5.34	OR 6995	1
032	Key	65-250	d=24 mm	EN 1.4401 (AISI 316)	8x7x30	UNI 6604
		80-200	d=24 mm			
		80-250	d=29 mm			
034	impeller nut	65-250	d=24 mm	EN 1.4404 (AISI 316L)	M20x1.5	UNI 7474
		80-200	d=24 mm			
		80-250	d=29 mm			
042A	Foot for pump		Aluminium/zincked steel (only for 80-250/55)			[2]
075	Washer (plug)		EN 1.4404 (AISI 316L)			1
076	Washer (plug)					1
077	O-ring (plug)		FPM			1
078	O-ring (plug)		EPDM (E version)			1
200	Screw		Stainless steel A2-70 class ISO 3506/1	M 12x45	UNI 5739	10
235	Washer		EN 1.4301(AISI 304)	13	UNI 8842	10
244	Pin [3]		EN 1.4301(AISI 304)	4x12		1

Counterflange kit on request, see table p. 319-320

[1] Only for 65-250/37 , 80-200/37 , 80-250/37 – 80-250/45 and 80-250/55

[2] N° for 1 unit=2 for 80-200/30 , 80-200/37 , 80-250/45

for 1 unit=1 for 80-250/55

[3] Not for H and E version.

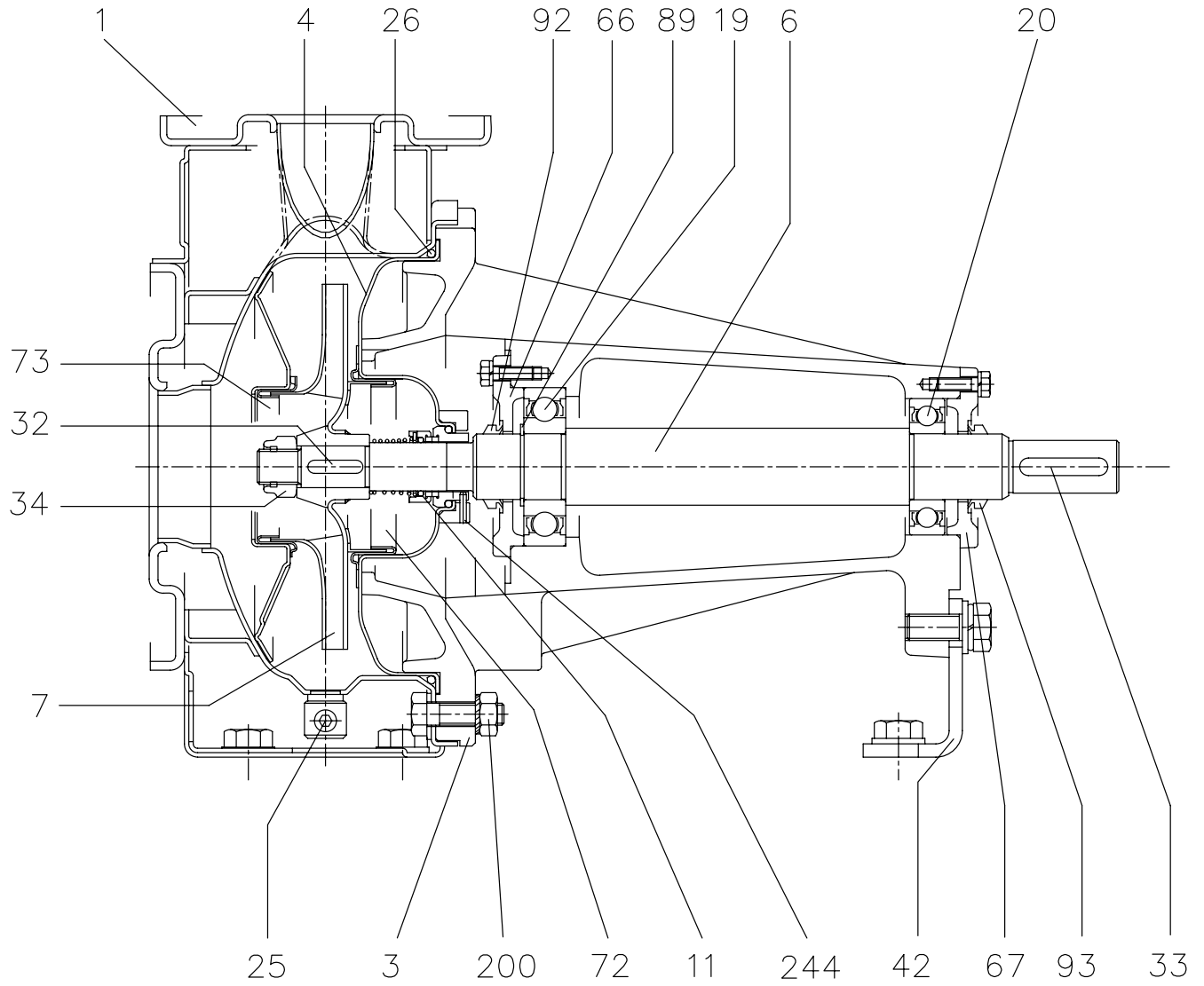

N°	PART NAME	MATERIAL		DIMENSIONS	STANDARD	N. FOR 1 UNIT	
		3P	3LP				
001	Casing	EN 1.4301 (AISI 304)	EN 1.4404 (AISI 316L)			1	
003	Support	Cast iron EN-GJL-200-EN 1561				1	
004	Casing cover	EN 1.4301 (AISI 304)	EN 1.4404 (AISI 316L)			1	
006	Shaft - Part in contact with liquid	EN 1.4301 (AISI 304)	EN 1.4404 (AISI 316L)			1	
007	Impeller	EN 1.4301 (AISI 304)	EN 1.4404 (AISI 316L)			1	
		EN 1.4401 (AISI 316)					
011	Mechanical seal	Carbon/Ceramic/NBR Carbon/Ceramic/FPM (H option) SiC/SiC/FPM (HS option)	SiC/SiC/FPM	See p. 313-317		1	
019	Bearing	-		See table p. 312		1	
020	Bearing	-		See table p. 312		1	
025	Draing plug	EN 1.4401 (AISI 316) / PTFE		R 1/8" L=8	DIN 906	1	
026	"O" ring	NBR FPM (H - HS option)	FPM	32-125, 40-125 32-160, 40-160, 50-125, 65-125	158.11x5.34	OR 6625	1
				32-200, 40-200, 50-160, 50-200, 65-160, 65-200	183.52x5.34	OR 6720	
					227.96x5.34	OR 6895	
032	Key	EN 1.4301 (AISI 304)	EN 1.4401 (AISI 316)	6x6x25 8x7x30	UNI 6604	1	
033	Key	C 40		8x7x40	UNI 6604	1	
034	Impeller nut	EN 1.4301 (AISI 304)	EN 1.4404 (AISI 316L)	Up to 11kW 50-200/15	M16x1.5	UNI 7474	1
				15 kW and above	M18x1.5		
					M20x1.5		
042	Pump support	Fe 37 Zinc-coated			EBARA DRAWING	1	
066	Impeller side bearing cover	Cast iron EN-GJL-200-EN 1561				1	
067	Motor side bearing cover	Cast iron EN-GJL-200-EN 1561				1	
072	Casing ring [1]	EN 1.4301 (AISI 304)	EN 1.4404 (AISI 316L)			1	
073	Casing ring (not for 65 version)	EN 1.4301 (AISI 304)	EN 1.4404 (AISI 316L)			1	
089	Snap ring	Carbon tool steels TC 80		Ø 40	UNI 7435	1	
092	"V" ring	-		VS - 0030		1	
093	"V" ring	-		VS - 0030		1	
200	Screw	Stainless steel A2 70 class ISO 3506/1		32-125, 40-125 40-160, 40-200, 50-125, 50-160, 50-200, 65-125, 65-160, 65-200	M 8x30	UNI 5739	8
					M 10x35	UNI 5739	[2]
244	Pin [3]	-	EN 1.4301 (AISI 304)	4x15		1	

Counterflange kit on request see p. 319-320

[1] For version 32-200, 40-200, 50-160, 50-200

[2] N° for 1 unit=10 for 32-160, 40-160, 50-125, 65-125

N° for 1 unit=12 for 32-200, 40-200, 50-160, 50-200, 65-160, 65-200

[3] Only for 65-160/15 and 65-200



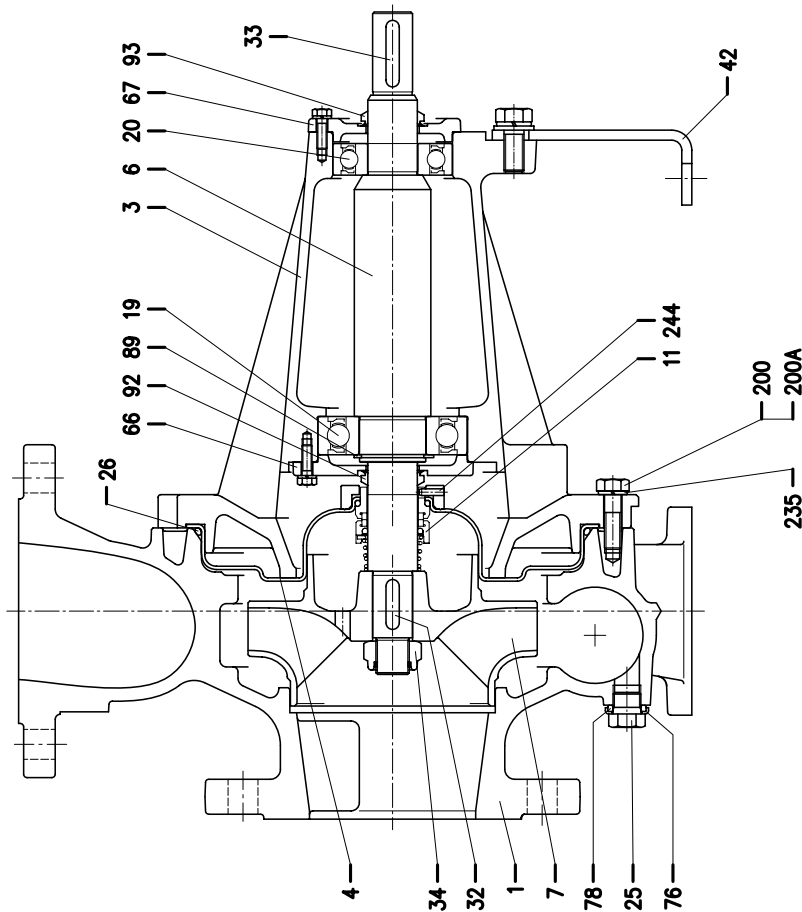
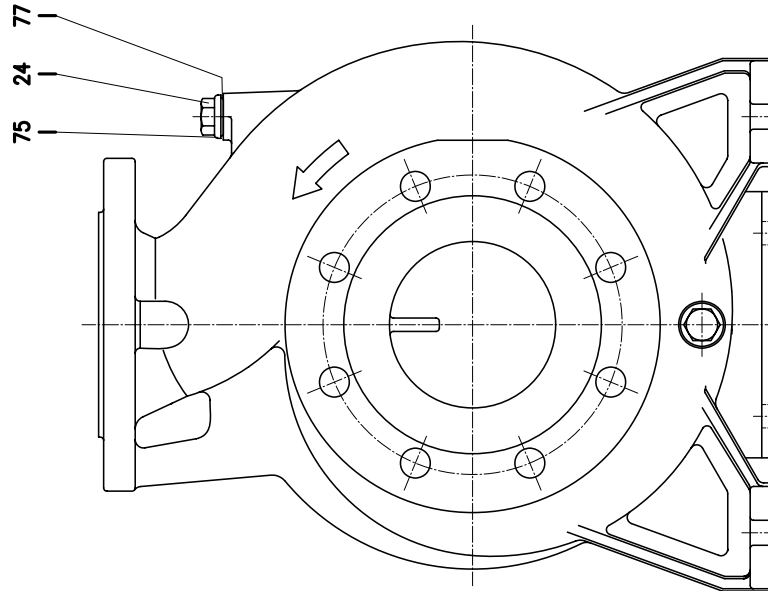

N°	PART NAME	MATERIAL	DIMENSIONS	STANDARD	N. FOR 1 UNIT
001	Casing	EN 1.4401 (AISI316)			1
003	Support	Cast iron EN-GJL-200-EN 1561			1
004	Casing cover	EN 1.4404 (AISI316L)			1
006	Shaft	EN 1.4404 (AISI316L)-Part in contact with liquid			1
007	Impeller	EN 1.4401 (AISI316)			1
011	Mechanical seal	SiC/SiC/FPM Ceramic/Carbon/FPM (H option) SiC/Carbon/EPDM (E option)	See p. 313-317		1
019	Bearing	-	See table p. 312		1
020	Bearing	-	See table p. 312		1
024	Plug	EN 1.4404 (AISI316L)	G3/8	EPE DRAWING	1
025	Plug	EN 1.4404 (AISI316L)	G3/8	EPE DRAWING	1
026	"O" ring	FPM EPDM (E option)	227.96x5.34	OR 6895	1
032	Key	EN 1.4401 (AISI 316)	8x7x30	UNI 6604	1
033	Key	C 40	8x7x40		1
034	Impeller nut	EN 1.4404 (AISI 316L)	M20x1.5	UNI 7474	1
042	Pump support	Zincked steel		EPE DRAWING	1
066	Impeller side bearing cover	Cast iron EN-GJL-200-EN 1561			1
067	Motor side bearing cover	Cast iron EN-GJL-200-EN 1561			1
075	Washer (plug)	EN 1.4404 (AISI 316L)			1
076	Washer (plug)				1
077	O-ring (plug)	FPM			1
078	O-ring (plug)	EPDM (E option)			1
089	Snap ring	Carbon tool steels TC 80	Ø 40	UNI 7435	1
092	"V" ring		VS-0030		1
093	"V" ring				1
200	Screw	Stainless steel A2 70 class ISO 3506/1	M 10x35	UNI 5739	10
200A	Screw		M 10x30		2
235	Washer	EN 1.4301(AISI 304)	10.5	UNI 8842	12
244	Pin [1]	EN 1.4301(AISI 304)	4x15		1

Counterflange kit on request, see table p. 319-320

[1] Not for H and E option.

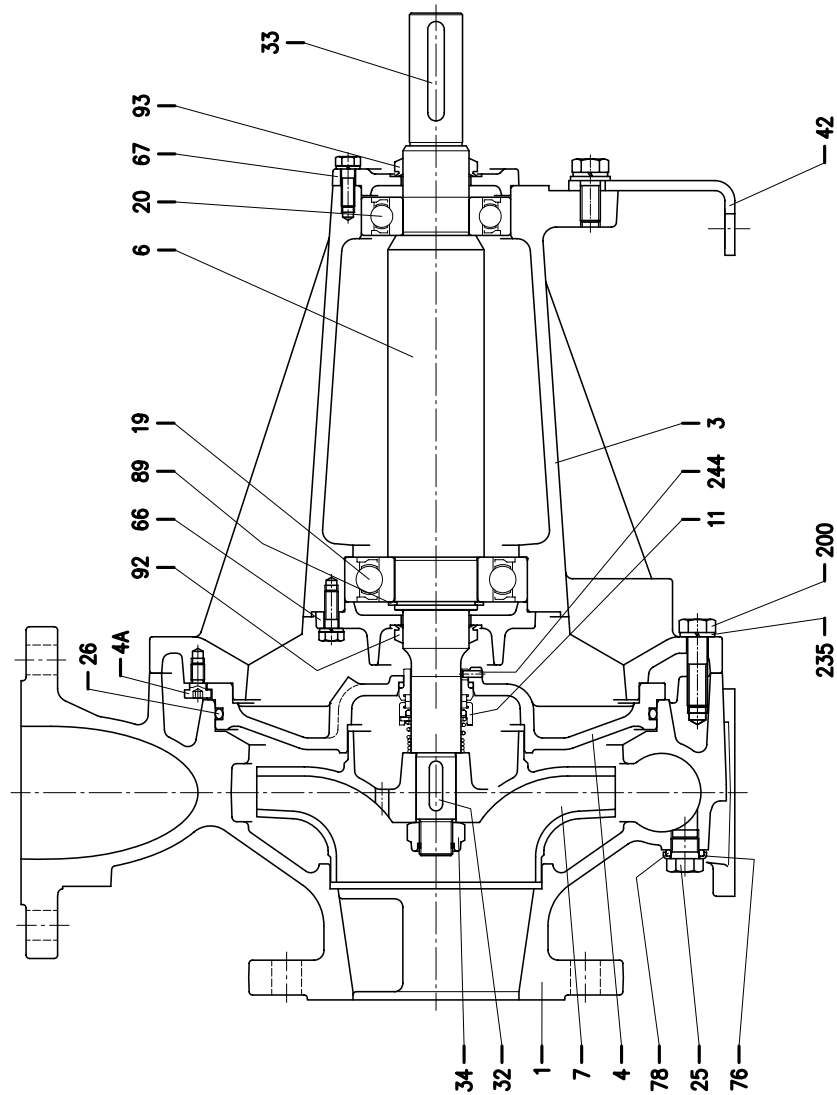
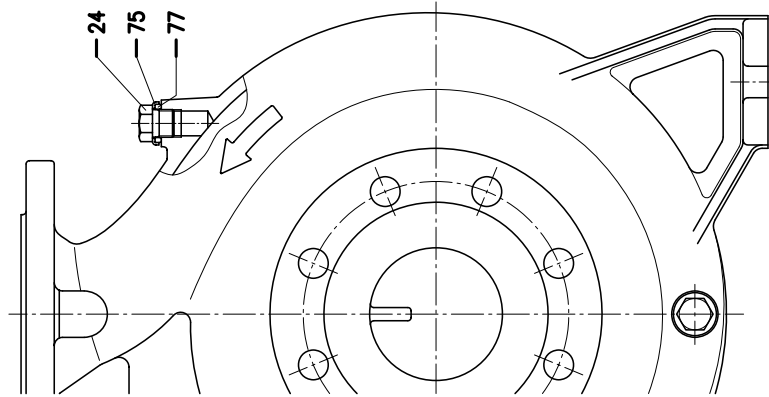

N°	PART NAME		MATERIAL	DIMENSIONS	STANDARD	N. FOR 1 UNIT	
001	Casing		EN 1.4401 (AISI316)			1	
003	Support		Cast iron EN-GJL-200-EN 1561			1	
004	Casing cover		EN 1.4401 (AISI316)			1	
004A	Screw for casing cover		EN 1.4301 (AISI 304)			2	
006	Shaft		EN 1.4462 (Duplex stainless steel)-Part in contact with liquid			1	
007	Impeller		EN 1.4401 (AISI316)			1	
011	Mechanical seal		Sic/Sic/FPM Ceramic/Carbon/FPM (H option) Sic/Carbon/EPDM (E option)	See p. 313-317		1	
019	Bearing		-	See table p. 312		1	
020	Bearing		-	See table p. 312		1	
024	Plug		EN 1.4404 (AISI316L)	G3/8		1	
025	Plug		EN 1.4404 (AISI316L)	G3/8		1	
026	"O" ring		FPM EPDM (E version)	253.36x5.34	OR 6995	1	
032	Key	65-250	EN 1.4401 (AISI 316)	8x7x30	UNI 6604	d=24 mm	1
		80-200				d=29 mm	1
		80-250					1
033	Key		C 40	10x8x60	UNI 6604	1	
034	impeller nut	65-250	EN 1.4404 (AISI 316L)	M20x1.5	UNI 7474	d=24 mm	1
		80-200				d=29 mm	1
		80-250					1
042	Pump support		Zincked steel			1	
066	Impeller side bearing cover		Cast iron EN-GJL-200-EN 1561			1	
067	Motor side bearing cover		Cast iron EN-GJL-200-EN 1561			1	
075	Washer (plug)		EN 1.4404 (AISI 316L)			1	
076	Washer (plug)					1	
077	O-ring (plug)			FPM			1
078	O-ring (plug)		EPDM (E version)			1	
089	Snap ring		Carbon tool steels TC 80	Ø 50	UNI 7435	1	
092	"V" ring		-	VS-0040		1	
093	"V" ring		-	VS-0040		1	
200	Screw		Stainless steel A2 70 class ISO 3506/1	M 12x45	UNI 5739	10	
235	Washer		EN 1.4301 (AISI 304)	13	UNI 8842	10	
244	Pin [1]		EN 1.4301 (AISI 304)	4x12	UNI 6873	1	

Counterflange kit on request, see table p. 319-320

[1] Not for H and E option.

**BALL BEARING**

Type pumps 50 Hz	Ball bearing	
	Pump side	Motor side
32-125		
32-160/R	6306-2RS1 C3	6206-2RS1 C3
32-160		
32-200/R		
32-200	6308-2RS1 C3	6306-2RS1 C3
32-200/L		
40-125/R		
40-125	6306-2RS1 C3	6206-2RS1 C3
40-160/R		
40-160		
40-200/R		
40-200	6308-2RS1 C3	6306-2RS1 C3
40-200/L		
50-125/S		
50-125/R	6306-2RS1 C3	6206-2RS1 C3
50-125		
50-160/R		
50-160		
50-200/R	6308-2RS1 C3	6306-2RS1 C3
50-200		
50-200/L		
65-125/R		
65-125	6306-2RS1 C3	6206-2RS1 C3
65-125/L		
65-160/S		
65-160/R		
65-160		
65-160/L	6308-2RS1 C3	6306-2RS1 C3
65-200/R		
65-200		
65-200/L		
65-250	6310-2RS1 C3	6308-2RS1 C3
65-250/L		
80-160/S		
80-160/R	6308-2RS1 C3	6306-2RS1 C3
80-160		
80-160/L		
80-200/R		
80-200		
80-200/L	6310-2RS1 C3	6308-2RS1 C3
80-250/R		
80-250		
80-250/L		

MECHANICAL SEAL STANDARD AND H VERSION

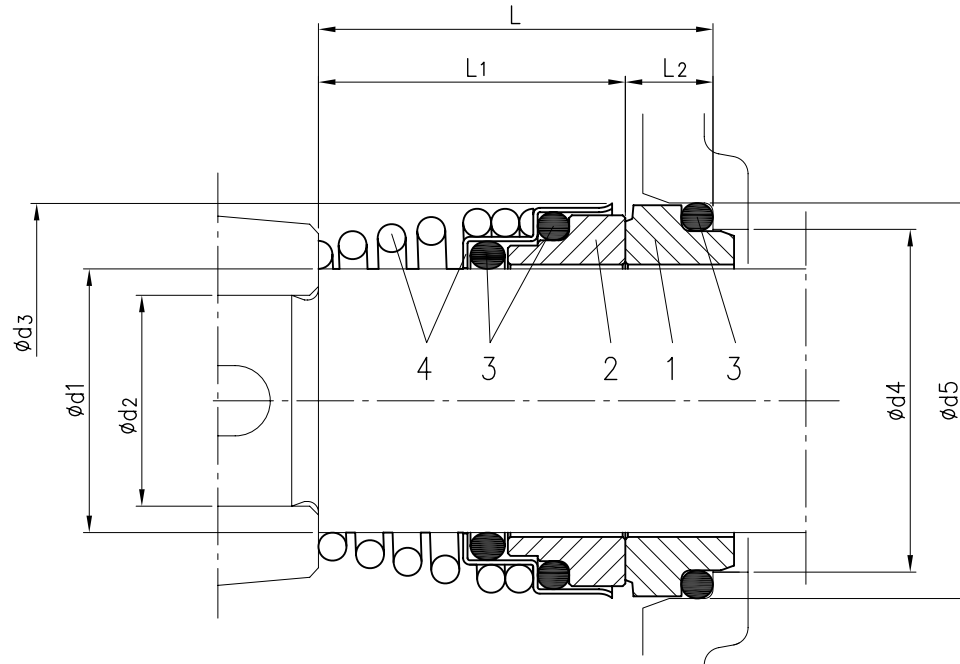

Version	Manufacturer Reference			Pump type	Dimensions							Material				
	Manuf.	Description	Material Description		d1	d2	d3	d4	d5	L	L1	L2	1 Stationary seal ring	2 Rotary seal ring	3 rubber	4 Frame + spring
Standard	Roten	UNITEN 3K	X6X62V6	32-125/160/200	22	19	38	31	37	37.5	27.5	10	Carbon	Ceramic	NBR	EN 1.4401 (AISI 316)
				40-125/160/200												
H	Roten	UNITEN 3K	XYXY2VY	50-125/160/200	22	19	38	31	37	37.5	27.5	10	Carbon	Ceramic	FPM	EN 1.4401 (AISI 316)
				65-125												
H	Roten	UNITEN 3K	XYXY2VY	65-160/7.5	22	19	38	31	37	37.5	27.5	10	Carbon	Ceramic	FPM	EN 1.4401 (AISI 316)
				65-160/9.2												
H	Roten	UNITEN 3K	XYXY2VY	65-160/11	22	19	38	31	37	37.5	27.5	10	Carbon	Ceramic	FPM	EN 1.4401 (AISI 316)
				65-160/15												
H	Roten	UNITEN 3K	XYXY2VY	65-200	30	24	46	39	45	42.5	32.5	10	Carbon	Ceramic	FPM	EN 1.4401 (AISI 316)
				65-250												
H	Roten	UNITEN 3K	XYXY2VY	80-160/200	35	29	50	44	50	42.5	32.5	10	Carbon	Ceramic	FPM	EN 1.4401 (AISI 316)
				80-250												

MECHANICAL SEAL L VERSION Ø22

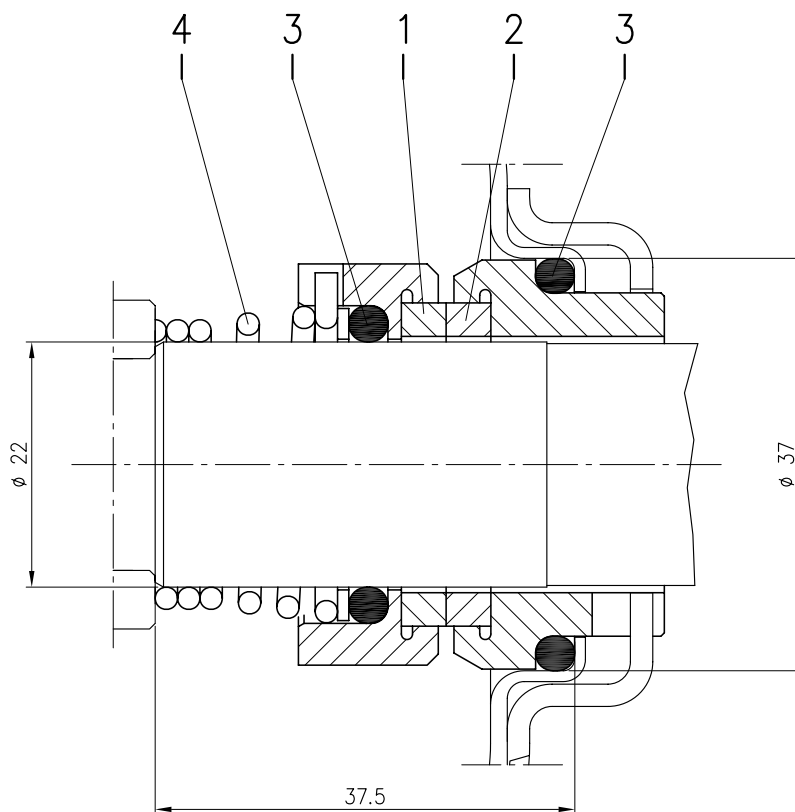

Manufacturer Reference			Pump type	Material			
Manuf.	Description	Material Description		1 Stationary seal ring	2 Rotary seal ring	3 rubber	4 Frame + spring
Burgmann	M377GN85/22-00-R	Q1Q1VGG	32-125/160/200 40-125/160/200 50-125/160/200 65-125 65-160/7.5 65-160/9.2 65-160/11	SiC	SiC	FPM	EN 1.4571 (AISI 316Ti)

MECHANICAL SEAL L VERSION

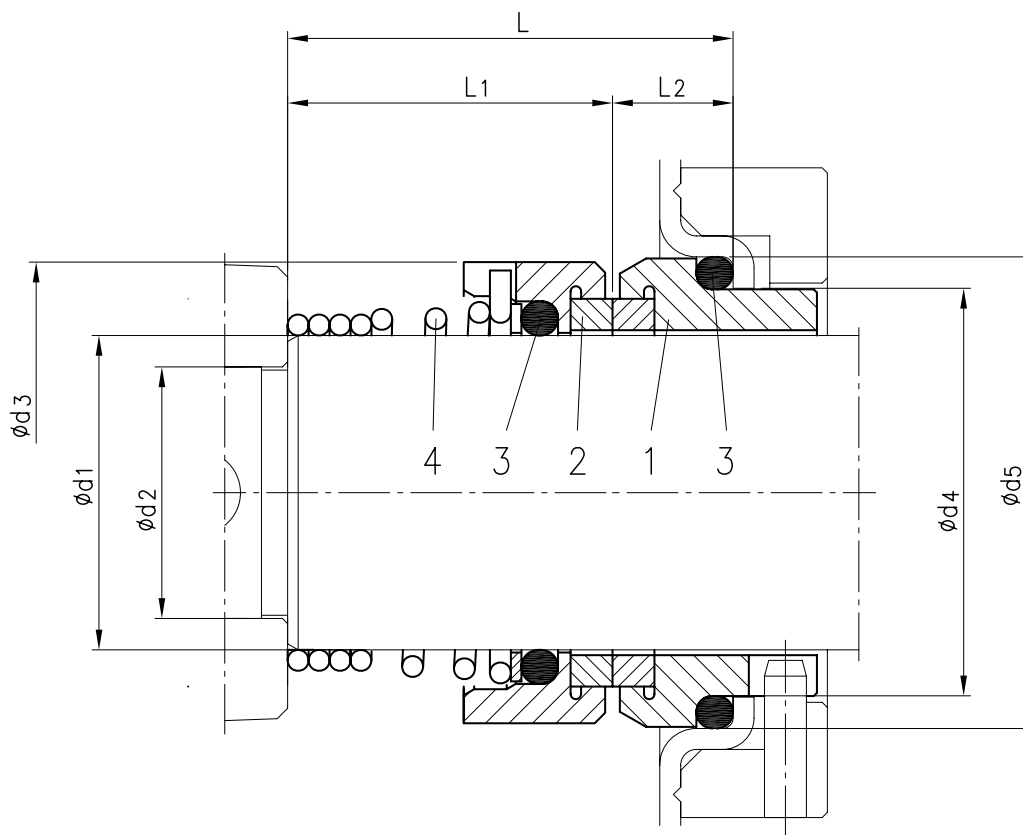

Manufacturer Reference			Pump type	Dimensions							Material				
Manuf.	Description	Material Description		d1	d2	d3	d4	d5	L	L1	L2	1 Stationary seal ring	2 Rotary seal ring	3 rubber	4 Frame + spring
Burgmann	M377GN85-R	Q1Q1VGG	65-160/15	30	24	44	39	45	42.5	31	11.5	SiC	SiC	FPM	EN 1.4571 (AISI 316Ti)
			65-200												
			65-250												
			80-160/200												
			80-250	35	29	49	44	50	42.5	31	11.5				



**MECHANICAL SEAL HS VERSION Ø22**

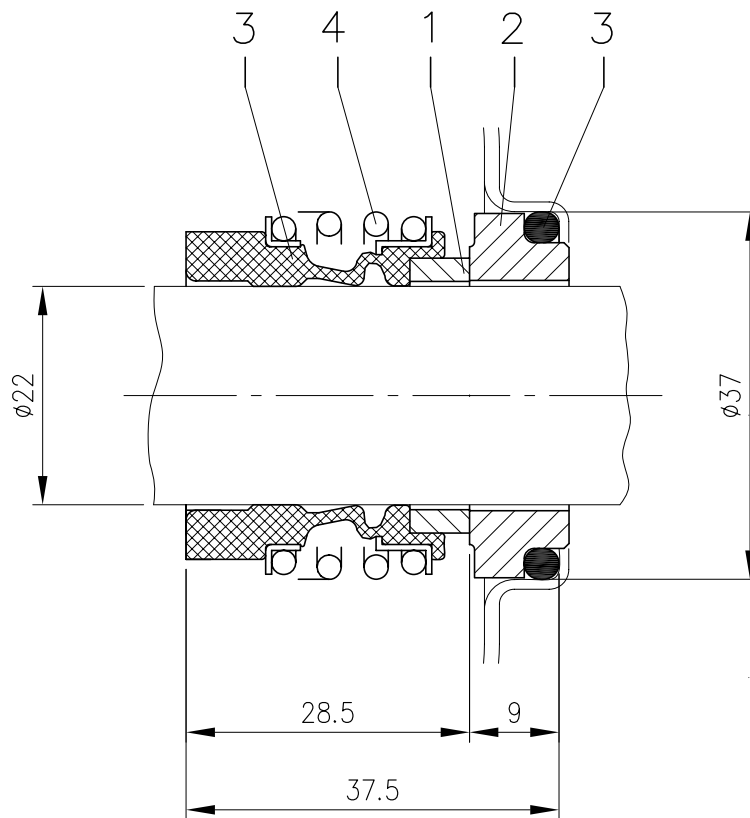

Manufacturer Reference			Pump type	Material			
Manuf.	Description	Material Description		1 Stationary seal ring	2 Rotary seal ring	3 rubber	4 Frame + spring
Burgmann	MG1S6/22-G3	Q1Q1VGG	32-125/160/200 40-125/160/200 50-125/160/200 65-125 65-160/7.5 65-160/9.2 65-160/11	SiC	SiC	FPM	EN 1.4571 (AISI 316Ti)

MECHANICAL SEAL HS AND E VERSION

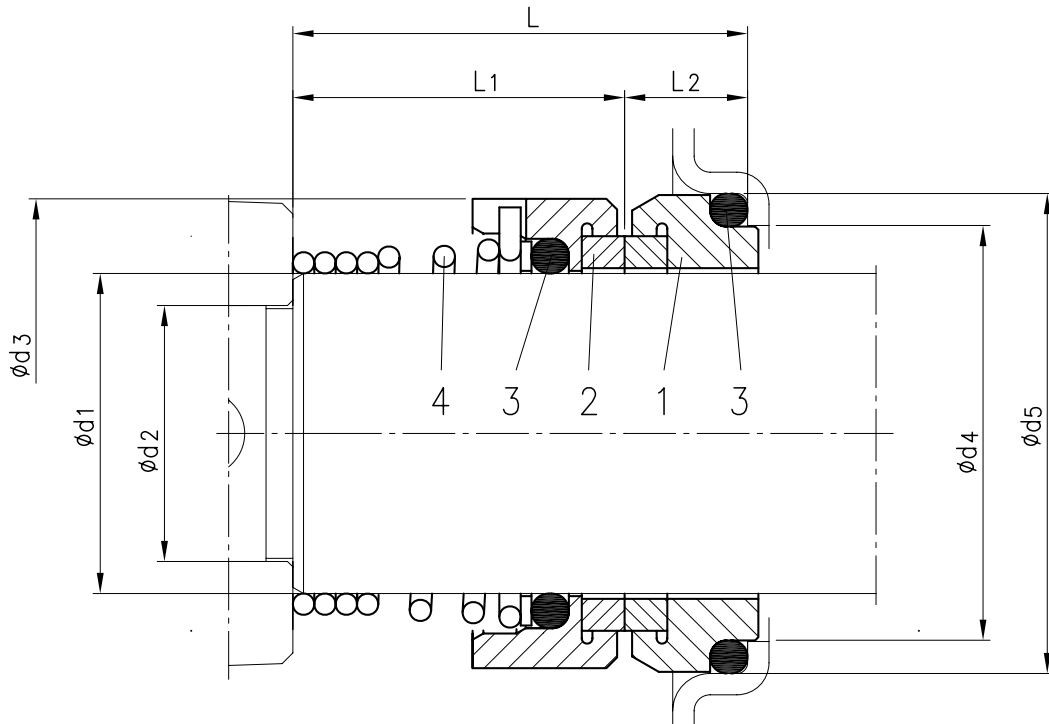

Version	Manufacturer Reference			Pump type	Dimensions							Material				
	Manuf.	Description	Material Description		d1	d2	d3	d4	d5	L	L1	L2	1 Stationary seal ring	2 Rotary seal ring	3 rubber	4 Frame + spring
HS	Burgmann	M377GNX/30-00-R	Q1Q1VGG	65-160/15	30	24	44	39	45	42.5	31	11.5	SiC	SiC	FPM	EN 1.4571 (AISI 316Ti)
			65-200													
E		M377GNX/35-00-R	Q1BEGG	65-250	30	24	44	39	45	42.5	31	11.5	Carbon	SiC	EPDM	EN 1.4571 (AISI 316Ti)
				80-160/200												
				80-250	35	29	49	44	50	42.5	31	11.5				

COUPLING

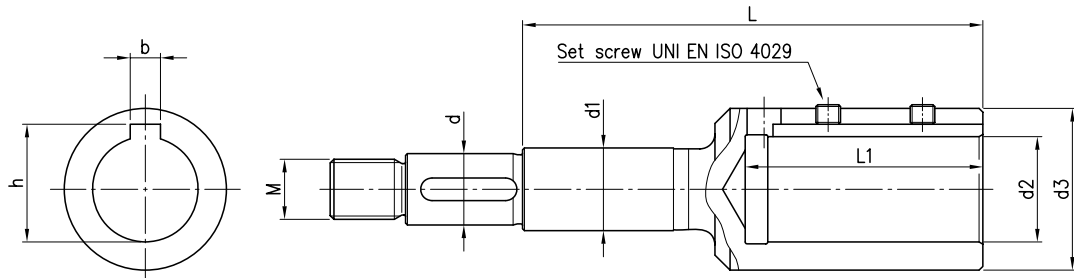

Type pumps	kW	HP	Motor Size	Dimensions mm										
				d	d1	d2	d3	M	L	L1	b	h	Set screw	
32-125/1.1	1.1	1.5	80	19	22	19	33	M16x1.5	98	43	6	21.8	M6x6	
32-160/1.5	1.5	2	90	19	22	24	39	M16x1.5	110	53	8	27.3	M8x8	
32-160/2.2	2.2	3	90	19	22	24	39	M16x1.5	110	53	8	27.3	M8x8	
32-200/3.0	3	4	100	19	22	28	43	M16x1.5	122	63	8	31.3	M8x8	
32-200/4.0	4	5.5	112	19	22	28	43	M16x1.5	122	63	8	31.3	M8x8	
32-200/5.5	5.5	7.5	132	19	22	38	58	M16x1.5	145	84	10	41.3	M8x8	
32-200/7.5	7.5	10	132	19	22	38	58	M16x1.5	145	84	10	41.3	M8x8	
40-125/1.5	1.5	2	90	19	22	24	39	M16x1.5	110	53	8	27.3	M8x8	
40-125/2.2	2.2	3	90	19	22	24	39	M16x1.5	110	53	8	27.3	M8x8	
40-160/3.0	3	4	100	19	22	28	43	M16x1.5	122	63	8	31.3	M8x8	
40-160/4.0	4	5.5	112	19	22	28	43	M16x1.5	122	63	8	31.3	M8x8	
40-200/5.5	5.5	7.5	132	19	22	38	58	M16x1.5	145	84	10	41.3	M8x8	
40-200/7.5	7.5	10	132	19	22	38	58	M16x1.5	145	84	10	41.3	M8x8	
40-200/11	11	15	160	19	22	42	63	M16x1.5	178	114	12	45.3	M8x8	
50-125/2.2	2.2	3	90	19	22	24	39	M16x1.5	110	53	8	27.3	M8x8	
50-125/3.0	3	4	100	19	22	28	43	M16x1.5	122	63	8	31.3	M8x8	
50-125/4.0	4	5.5	112	19	22	28	43	M16x1.5	122	63	8	31.3	M8x8	
50-160/5.5	5.5	7.5	132	19	22	38	58	M16x1.5	145	84	10	41.3	M8x8	
50-160/7.5	7.5	10	132	19	22	38	58	M16x1.5	145	84	10	41.3	M8x8	
50-200/9.2	9.2	12.5	132	19	22	38	58	M16x1.5	145	84	10	41.3	M8x8	
50-200/11	11	15	160	19	22	42	63	M16x1.5	178	114	12	45.3	M8x8	
50-200/15	15	20	160	22	22	42	63	M18x1.5	209	114	12	45.3	M8x8	
65-125/4.0	4	5.5	112	19	22	28	43	M16x1.5	122	63	8	31.3	M8x8	
65-125/5.5	5.5	7.5	132	19	22	38	58	M16x1.5	145	84	10	41.3	M8x8	
65-125/7.5	7.5	10	132	19	22	38	58	M16x1.5	145	84	10	41.3	M8x8	
65-160/7.5	7.5	10	132	19	22	38	58	M16x1.5	145	84	10	41.3	M8x8	
65-160/9.2	9.2	12.5	132	19	22	38	58	M16x1.5	145	84	10	41.3	M8x8	
65-160/11	11	15	160	19	22	42	63	M16x1.5	178	114	12	45.3	M8x8	
65-160/15	15	20	160	24	30	42	63	M20x1.5	184	114	12	45.3	M8x8	
65-200/15	15	20	160	24	30	42	63	M20x1.5	184	114	12	45.3	M8x8	
65-200/18.5	18.5	25	160	24	30	42	63	M20x1.5	184	114	12	45.3	M8x8	
65-200/22	22	30	180	24	30	48	72	M20x1.5	184	114	14	51.8	M10x10	
65-250/30	30	40	200	24	30	55	85	M20x1.5	184	114	16	59.3	M12x12	
65-250/37	37	50	200	24	30	55	85	M20x1.5	184	114	16	59.3	M12x12	
80-160/11	11	15	160	24	30	42	63	M20x1.5	184	114	12	45.3	M8x8	
80-160/15R	15	20	160	24	30	42	63	M20x1.5	184	114	12	45.3	M8x8	
80-160/15	15	20	160	24	30	42	63	M20x1.5	184	114	12	45.3	M8x8	
80-160/18.5	18.5	25	160	24	30	42	63	M20x1.5	184	114	12	45.3	M8x8	
80-200/22	22	30	180	24	30	48	72	M20x1.5	184	114	14	51.8	M10x10	
80-200/30	30	40	200	24	30	55	85	M20x1.5	184	114	16	59.3	M12x12	
80-200/37	37	50	200	24	30	55	85	M20x1.5	184	114	16	59.3	M12x12	
80-250/37	37	50	200	29	35	55	85	M24x2	206	114	16	59.3	M12x12	
80-250/45	45	60	225	29	35	55	85	M24x2	206	114	16	59.3	M12x12	
80-250/55	55	75	250	29	35	60	89	M24x2	218	144	18	64.4	M12x12	

COUNTERFLANGE ZINCKED STEEL

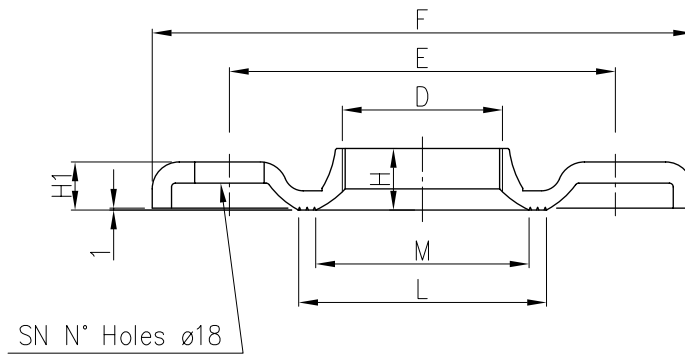

DN	D	Counterflange							Screw	
		E	F	H	H1	L	M	SN	DIMENSIONS	MATERIAL
32	G 1 1/4	100	100	15	11.5	67	50	4	M16x55	Zn. Steel 8.8 strenght class ISO 898-1
40	G 1 1/2	110	110	17.5	11.5	72	58	4		
50	G2	125	125	19	15	89	70	4		
65	G 2 1/2	145	185	23	14	104	88	4		
80	G3	160	200	24	16	117.5	100	8	M16x60	
100	G4	180	220	29	16	144	125	8		

COUNTERFLANGE EN 1.4404 (AISI 316L)

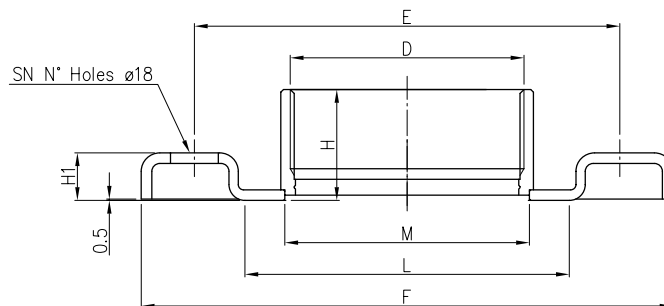

DN	D	Counterflange							Screw	
		E	F	H	H1	L	M	SN	DIMENSIONS	MATERIAL
32	G 1 1/4	100	140	29.5	14	66	44	4	M16x55	A2-70 class ISO 3506-1
40	G 1 1/2	110	150	29.5	14	71	50.5			
50	G 2	125	165	34	16	83	63			
65	G 2 1/2	145	185	40	16	103	80			
80	G3	160	200	42	18	122	92	8	M16x60	

COUNTERFLANGE EN 1.4404 (AISI 316L) DN100

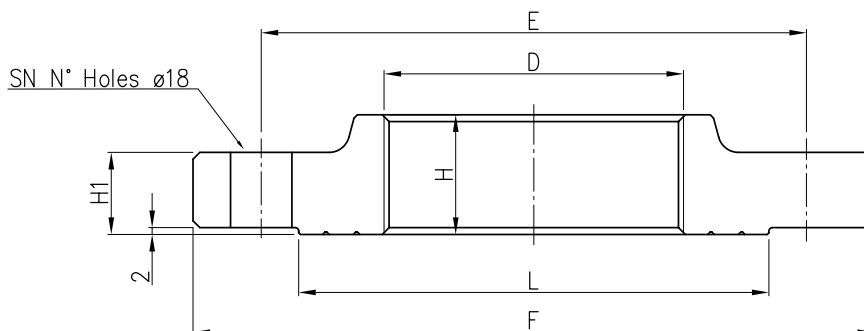

DN	D	Counterflange						Screw	
		E	F	H	H1	L	SN	DIMENSIONS	MATERIAL
100	G4	180	220	35	20	150	8	M16x70	A2-70 class ISO 3506-1

GASKET

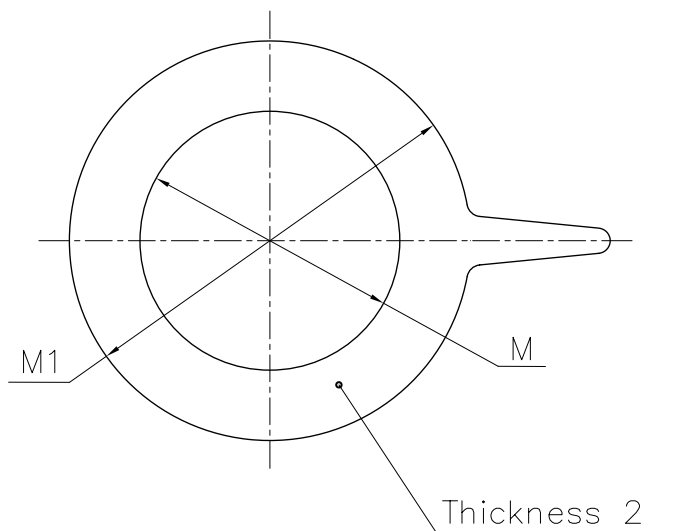

DN	M	M1
32	38	82
40	50	93
50	60	107
65	80	125
80	90	140
100	115	160

Material : EPDM for standard version  
FPM for L version

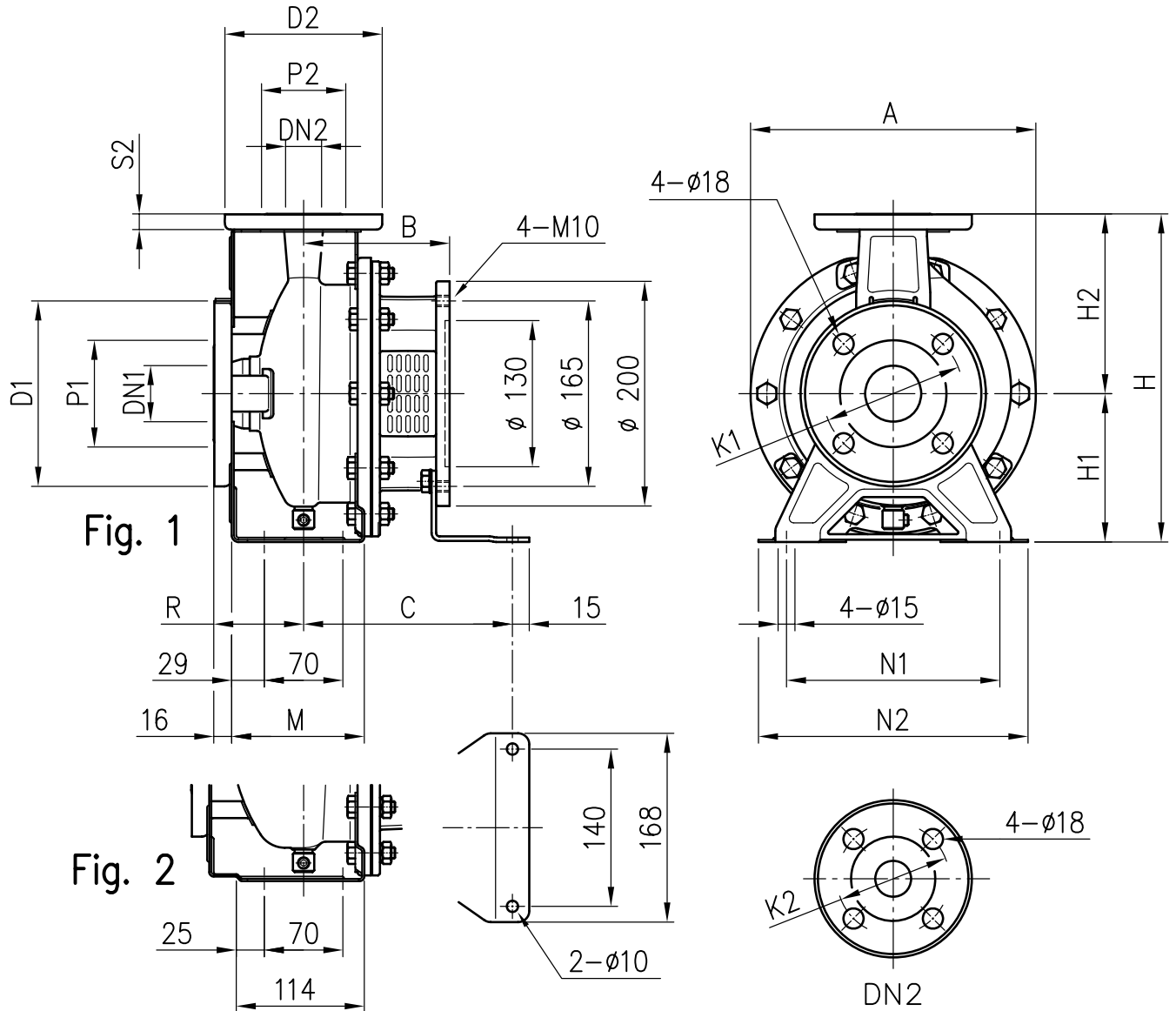

Pump type	Fig.	Dimensions [mm]																		Weight [kgf]	
		DN1	P1	K1	D1	DN2	P2	K2	D2	S2	H	H1	H2	M	N1	N2	R	A	B		C
32-125/1.1	1	50	95	125	165	32	75	100	140	14	252	112	140	114	140	190	80	213	118	174	13.1
32-160/1.5	1	50	95	125	165	32	75	100	140	14	292	132	160	118	190	240	80	254	130	186	17
32-160/2.2	1	50	95	125	165	32	75	100	140	14	292	132	160	118	190	240	80	254	130	186	17
40-125/1.5	1	65	115	145	185	40	80	110	150	14	252	112	140	114	160	210	80	213	130	186	14.4
40-125/2.2	1	65	115	145	185	40	80	110	150	14	252	112	140	114	160	210	80	213	130	186	14.5
50-125/2.2	2	65	115	145	185	50	95	125	165	16	292	132	160	-	190	240	100	254	130	186	20

DIMENSIONS 3(.)SF 32,40,50,65

50 Hz

Rev. G

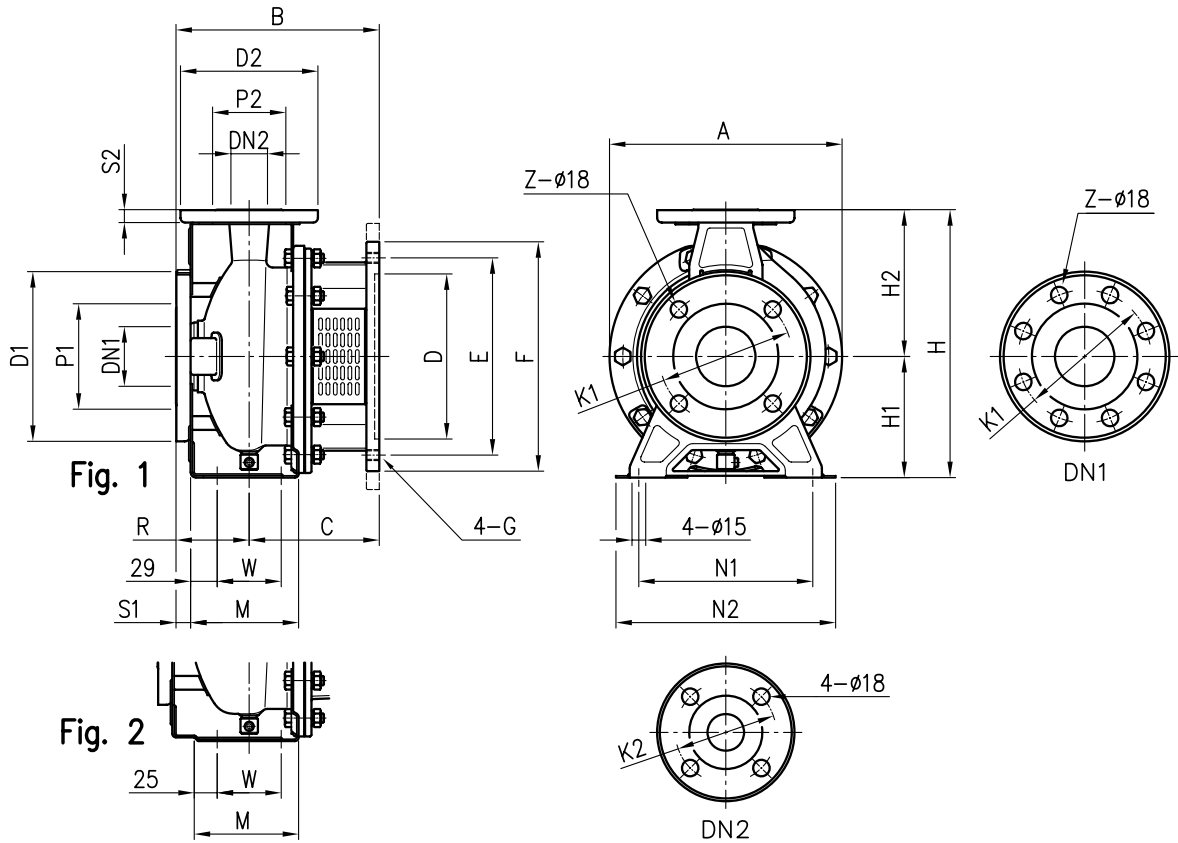

Pump type	Fig.	Dimensions [mm]																							Weight [kgf]				
		DN1	P1	K1	D1	S1	Z [1] [2]	DN2	P2	K2	D2	S2	H	H1	H2	M	N1	N2	R	W	A	B	C	D		E	F	G	
32-200/3	1	50	95	125	165	16	4	-	32	75	100	140	14	340	160	180	119	190	240	80	70	296	222	142	180	215	250	M12	24
32-200/4	1	50	95	125	165	16	4	-	32	75	100	140	14	340	160	180	119	190	240	80	70	296	222	142	180	215	250	M12	24
32-200/5.5	1	50	95	125	165	16	4	-	32	75	100	140	14	340	160	180	119	190	240	80	70	296	245	165	230	265	300	M12	28
32-200/7.5	1	50	95	125	165	16	4	-	32	75	100	140	14	340	160	180	119	190	240	80	70	296	245	165	230	265	300	M12	28
40-160/3	1	65	115	145	185	16	4	-	40	80	110	150	14	292	132	160	118	190	240	80	70	254	222	142	180	215	250	M12	19.5
40-160/4	1	65	115	145	185	16	4	-	40	80	110	150	14	292	132	160	118	190	240	80	70	254	222	142	180	215	250	M12	20
40-200/5.5	2	65	115	145	185	16	4	-	40	80	110	150	14	340	160	180	115	212	265	100	70	296	265	165	230	265	300	M12	28
40-200/7.5	2	65	115	145	185	16	4	-	40	80	110	150	14	340	160	180	115	212	265	100	70	296	265	165	230	265	300	M12	28
40-200/11	2	65	115	145	185	16	4	-	40	80	110	150	14	340	160	180	115	212	265	100	70	296	298	198	250	300	350	M16	41.5
50-125/3	2	65	115	145	185	16	4	-	50	95	125	165	16	292	132	160	114	190	240	100	70	254	242	142	180	215	250	M12	20
50-125/4	2	65	115	145	185	16	4	-	50	95	125	165	16	292	132	160	114	190	240	100	70	254	242	142	180	215	250	M12	20
50-160/5.5	2	65	115	145	185	16	4	-	50	95	125	165	16	340	160	180	115	212	265	100	70	296	265	165	230	265	300	M12	28.5
50-160/7.5	2	65	115	145	185	16	4	-	50	95	125	165	16	340	160	180	115	212	265	100	70	296	265	165	230	265	300	M12	28.5
50-200/9.2	2	65	115	145	185	16	4	-	50	95	125	165	16	360	160	200	115	212	265	100	70	296	265	165	230	265	300	M12	29
50-200/11	2	65	115	145	185	16	4	-	50	95	125	165	16	360	160	200	115	212	265	100	70	296	298	198	250	300	350	M16	41.5
50-200/15	2	65	115	145	185	16	4	-	50	95	125	165	16	360	160	200	115	212	265	100	70	296	298	198	250	300	350	M16	42.5
65-125/4	2	80	134	160	200	18	8	4	65	115	145	185	16	340	160	180	140	212	280	100	95	254	242	142	180	215	250	M12	26
65-125/5.5	2	80	134	160	200	18	8	4	65	115	145	185	16	340	160	180	140	212	280	100	95	254	265	165	230	265	300	M12	27.5
65-125/7.5	2	80	134	160	200	18	8	4	65	115	145	185	16	340	160	180	140	212	280	100	95	254	265	165	230	265	300	M12	28.5
65-160/7.5	2	80	134	160	200	18	8	4	65	115	145	185	16	360	160	200	140	212	280	100	95	296	265	165	230	265	300	M12	27
65-160/9.2	2	80	134	160	200	18	8	4	65	115	145	185	16	360	160	200	140	212	280	100	95	296	265	165	230	265	300	M12	30
65-160/11	2	80	134	160	200	18	8	4	65	115	145	185	16	360	160	200	140	212	280	100	95	296	298	198	250	300	350	M16	40
65-160/15	2	80	134	160	200	18	8	4	65	115	145	185	16	360	160	200	140	212	280	100	95	296	308	208	250	300	350	M16	42
65-200/15	2	80	134	160	200	18	8	4	65	115	145	185	16	405	180	225	140	250	320	100	95	296	308	208	250	300	350	M16	29.5
65-200/18.5	2	80	134	160	200	18	8	4	65	115	145	185	16	405	180	225	140	250	320	100	95	296	308	208	250	300	350	M16	29.5
65-200/22	2	80	134	160	200	18	8	4	65	115	145	185	16	405	180	225	140	250	320	100	95	296	308	208	250	300	350	M16	30

[1] Standards

[2] On request

DIMENSIONS **3(.)SF 65-250,80**

50 Hz

Rev. G

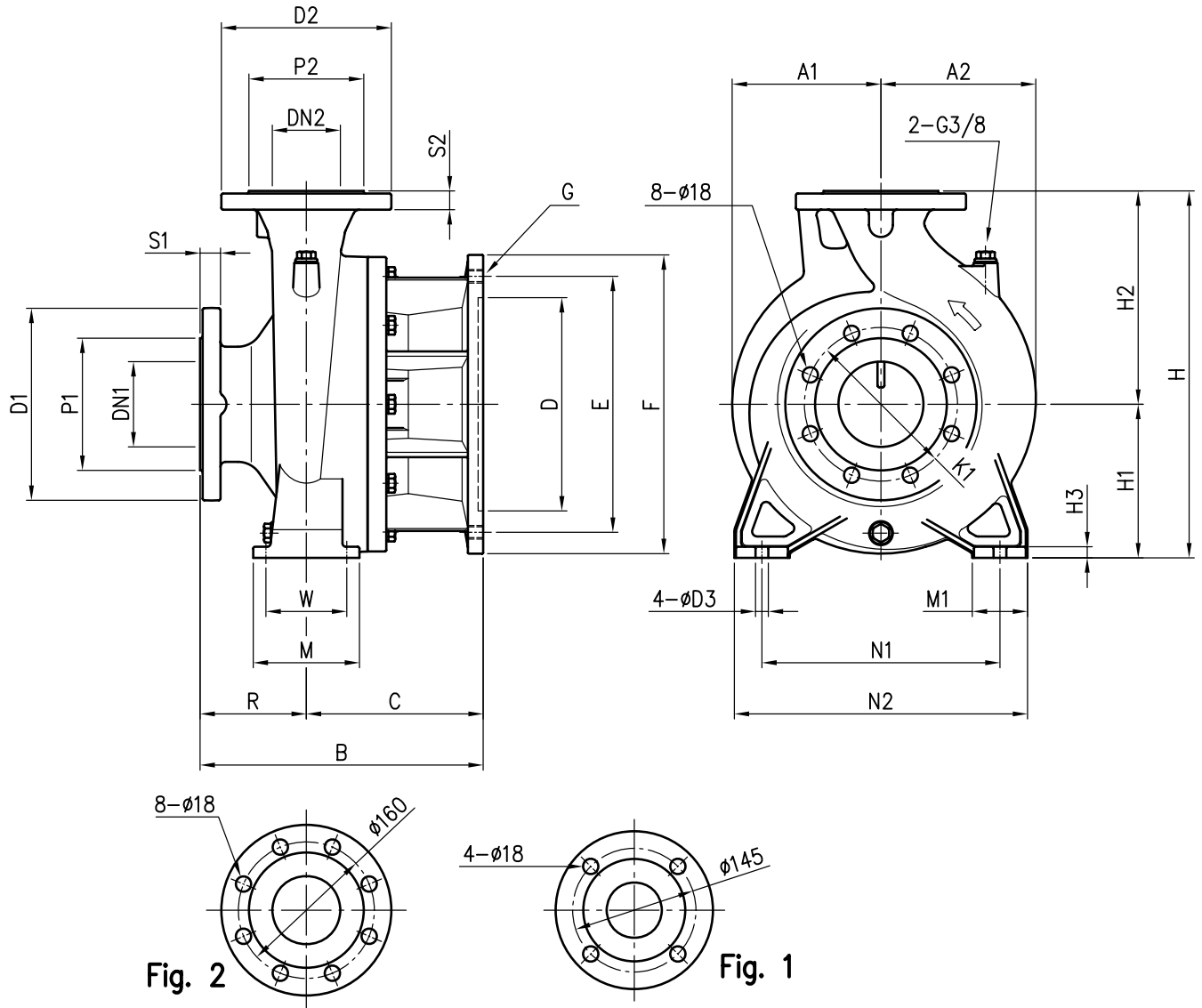

Pump type	Dimensions [mm]																				Weight [kg]								
	DN1	P1	K1	D1	S1	DN2	P2	D2	S2	H	H1	H2	H3	R	W	N1	N2	M	M1	D3		B	C	D	E	F	G	A1	A2
65-250/30	80	135	160	200	22	65 Fig. 1	120	185	20	450	200	250	15	100	120	280	360	160	80	19	308	208	300	350	400	4 - M16	200	200	70
65-250/37	80	135	160	200	22	65 Fig. 1	120	185	20	450	200	250	15	100	120	280	360	160	80	19	308	208	300	350	400	4 - M16	200	200	71
80-160/11	100	155	180	225	24	80 Fig. 2	135	200	22	405	180	225	13	125	95	250	320	125	65	15	333	208	250	300	350	4 - M16	175	175	52
80-160/15R	100	155	180	225	24	80 Fig. 2	135	200	22	405	180	225	13	125	95	250	320	125	65	15	333	208	250	300	350	4 - M16	175	175	52
80-160/15	100	155	180	225	24	80 Fig. 2	135	200	22	405	180	225	13	125	95	250	320	125	65	15	333	208	250	300	350	4 - M16	175	175	52
80-160/18.5	100	155	180	225	24	80 Fig. 2	135	200	22	405	180	225	13	125	95	250	320	125	65	15	333	208	250	300	350	4 - M16	175	175	53
80-200/22	100	155	180	225	24	80 Fig. 2	135	200	22	430	180	250	13	125	95	280	345	125	65	15	333	208	250	300	350	4 - M16	175	182	68
80-200/30	100	155	180	225	24	80 Fig. 2	135	200	22	430	180	250	13	125	95	280	345	125	65	15	333	208	300	350	400	4 - M16	200	200	72
80-200/37	100	155	180	225	24	80 Fig. 2	135	200	22	430	180	250	13	125	95	280	345	125	65	15	333	208	300	350	400	4 - M16	200	200	73
80-250/37	100	155	180	225	24	80 Fig. 2	135	200	22	480	200	280	15	125	120	315	400	160	80	19	361	236	300	350	400	4 - M16	200	200	83
80-250/45	100	155	180	225	24	80 Fig. 2	135	200	22	480	200	280	15	125	120	315	400	160	80	19	361	236	350	400	450	8 - M16	225	225	88
80-250/55	100	155	180	225	24	80 Fig. 2	135	200	22	480	200	280	15	125	120	315	400	160	80	19	373	248	450	550	500	8 - M16	275	275	100



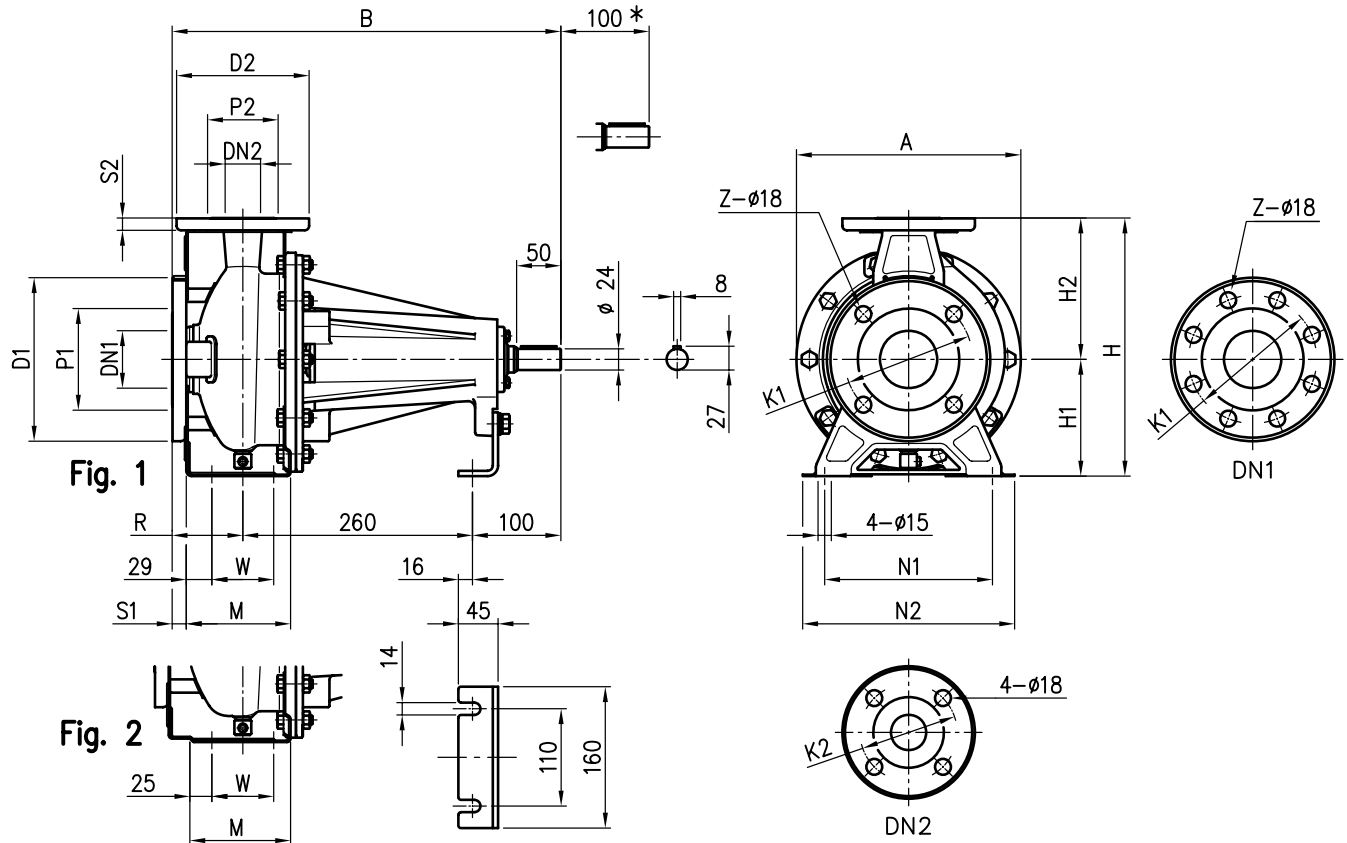

Pump type	Fig.	Dimensions [mm]																				Weight [kgf]		
		DN1	P1	K1	D1	S1	Z		DN2	P2	K2	D2	S2	H	H1	H2	M	N1	N2	R	W		A	B
32-125	1	50	95	125	165	16	4	-	32	75	100	140	14	252	112	140	114	140	190	80	70	213	440	17
32-160	1	50	95	125	165	16	4	-	32	75	100	140	14	292	132	160	118	190	240	80	70	254	440	19
32-200	1	50	95	125	165	16	4	-	32	75	100	140	14	340	160	180	119	190	240	80	70	296	440	27
40-125	1	65	115	145	185	16	4	-	40	80	110	150	14	252	112	140	114	160	210	80	70	213	440	17
40-160	1	65	115	145	185	16	4	-	40	80	110	150	14	292	132	160	118	190	240	80	70	254	440	19
40-200	2	65	115	145	185	16	4	-	40	80	110	150	14	340	160	180	115	212	265	100	70	296	460	27
50-125	2	65	115	145	185	16	4	-	50	95	125	165	16	292	132	160	114	190	240	100	70	254	460	19
50-160	2	65	115	145	185	16	4	-	50	95	125	165	16	340	160	180	115	212	265	100	70	296	460	28
50-200	2	65	115	145	185	16	4	-	50	95	125	165	16	360	160	200	115	212	265	100	70	296	460	27
65-125	2	80	134	160	200	18	8	4	65	115	145	185	16	340	160	180	140	212	280	100	95	254	460	28
65-160	2	80	134	160	200	18	8	4	65	115	145	185	16	360	160	200	140	212	280	100	95	296	460	29
65-200	2	80	134	160	200	18	8	4	65	115	145	185	16	405	180	225	140	250	320	100	95	296	460	30

[1] Standars [2] On request

\* Space for disassembly.

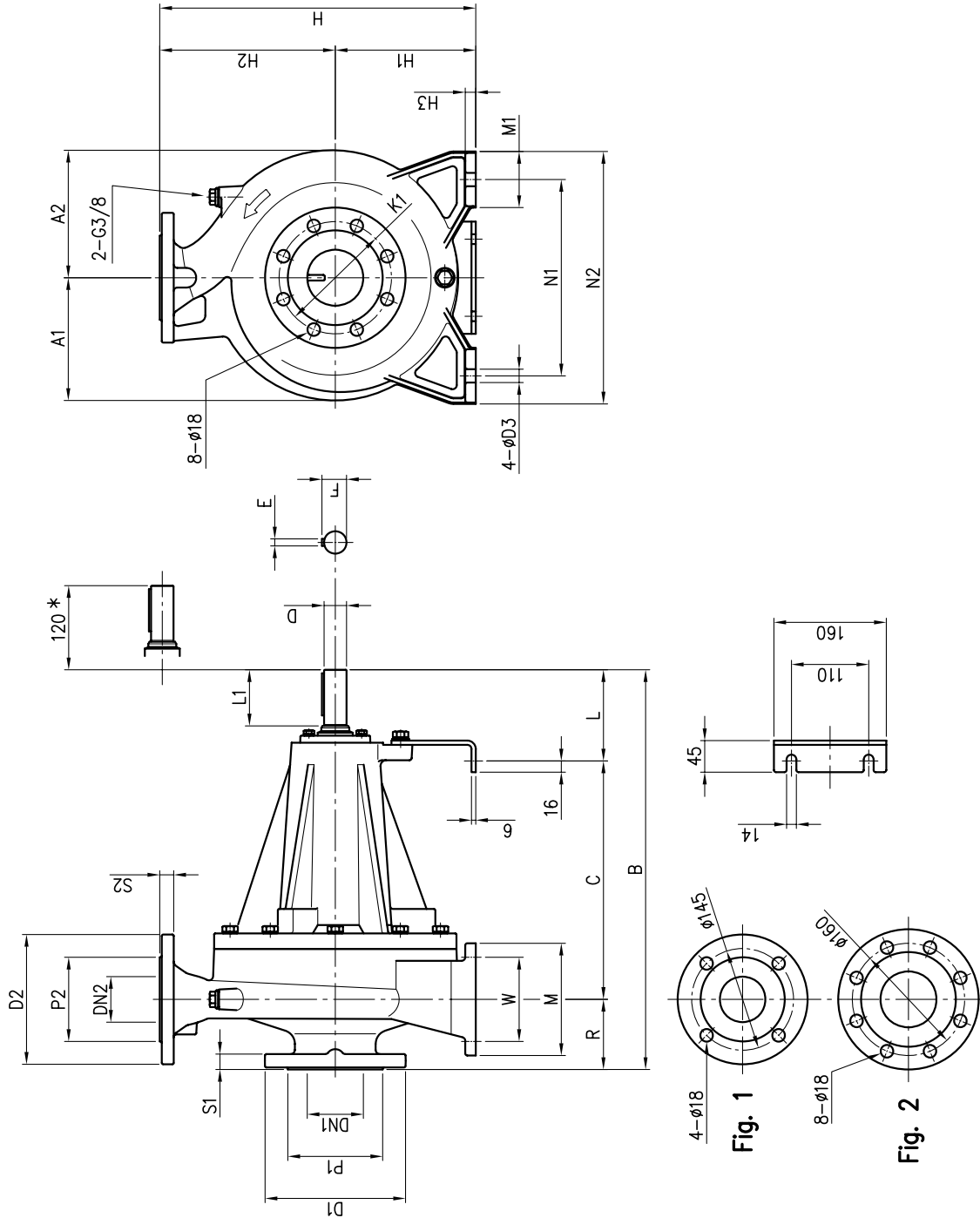

\* Space for disassembly

Pump type	Dimensions [mm]																				Weight [kgf]									
	DN1	P1	K1	D1	S1	DN2	P2	D2	S2	H	H1	H2	R	W	N1	N2	M	M1	L	L1		D	D3	E	F	A1	A2	B	C	
65-250	80	135	160	200	22	65 Fig. 1	120	185	20	450	200	250	15	100	120	280	360	160	80	130	80	32	19	10	35	175	182	570	340	82
80-160	100	155	180	225	24	80 Fig. 2	135	200	22	405	180	225	13	125	95	250	320	125	65	100	50	24	15	8	27	147	173	485	260	60
80-200	100	155	180	225	24	80 Fig. 2	135	200	22	430	180	250	13	125	95	280	345	125	65	130	80	32	15	10	35	175	182	595	340	83
80-250	100	155	180	225	24	80 Fig. 2	135	200	22	480	200	280	15	125	120	315	400	160	80	130	80	32	19	10	35	175	192	595	340	88

PACKING AND WEIGHT **3(.)SF**

50 Hz

Rev. G

Type pumps	PACKING [mm]			WEIGHT [Kg]	PACK TYPE			
	X	Y	Z					
32-125/1.1	374	424	405	16	1			
32-160/1.5				19				
32-160/2.2				27				
32-200/3				30				
32-200/4				17				
32-200/5.5				23				
32-200/7.5				30.5				
40-125/1.5				860		375	440	44.5
40-125/2.2								22.5
40-160/3								31.5
40-160/4								32
40-200/5.5								45
40-200/7.5								46
40-200/11								29
50-125/2.2	30.5							
50-125/3	31.5							
50-125/4	30							
50-160/5.5	33							
50-160/7.5	37							
50-200/9.2	33.5							
50-200/11	34							
50-200/15	75	608	2					
65-125/4	76							
65-125/5.5	58							
65-125/7.5	58							
65-160/7.5	58							
65-160/9.2	58							
65-160/11	75							
65-160/15	76							
65-200/15	58							
65-200/18.5	58							
65-200/22	75							
65-250/30	780	475	610					
65-250/37	80							
80-160/11	81							
80-160/15R	90							
80-160/15	95							
80-160/18.5	95							
80-200/22	108							
80-200/30	80							
80-200/37	81							
80-250/37	90							
80-250/45	95							
80-250/55	108							

TYPE 1

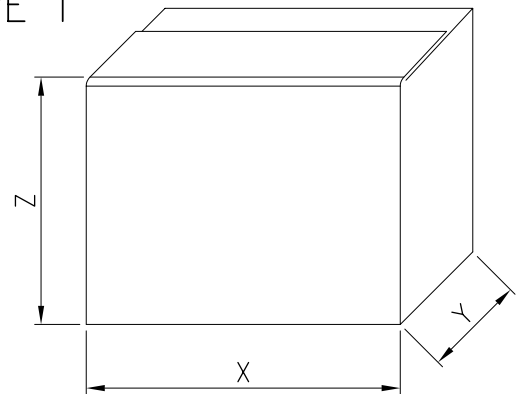

TYPE 2

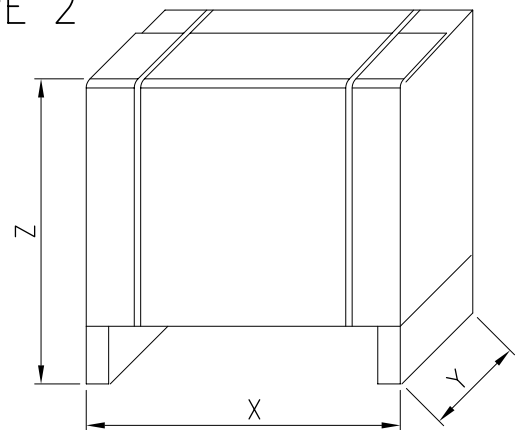

PACKING AND WEIGHT 3(.)PF

50 Hz

Rev. G

Type pumps	PACKING [mm]			WEIGHT [Kg]	PACK TYPE
	X	Y	Z		
32-125	490	280	340	18	1
32-160/R				20	
32-160				20	
32-200/R	500	330	390	28.5	
32-200				28.5	
32-200/L				28.5	
40-125/R	490	280	340	18	
40-125				18	
40-160/R				20	
40-160	500	330	390	20	
40-200/R				28.5	
40-200				28.5	
40-200/L	28.5				
50-125/S	490	280	340	20	
50-125/R				20	
50-125				20	
50-160/R	500	330	390	29	
50-160				29	
50-200/R				29.5	
50-200	500	330	390	29.5	
50-200/L				29.5	
65-125/R				29	
65-125	500	330	390	29	
65-125/L				29	
65-160/S				29	
65-160/R	580	390	533	30.5	
65-160				30.5	
65-160/L				30.5	
65-200/R	580	390	533	32	
65-200				32	
65-200/L				32	
65-250	780	475	608	86	
65-250/L				86	
80-160/S				86	
80-160/R	580	390	533	64	
80-160				64	
80-160/L				64	
80-200/R	780	475	610	87	
80-200				87	
80-200/L				87	
80-250/R	780	475	610	93	
80-250				93	
80-250/L				93	

TYPE 1

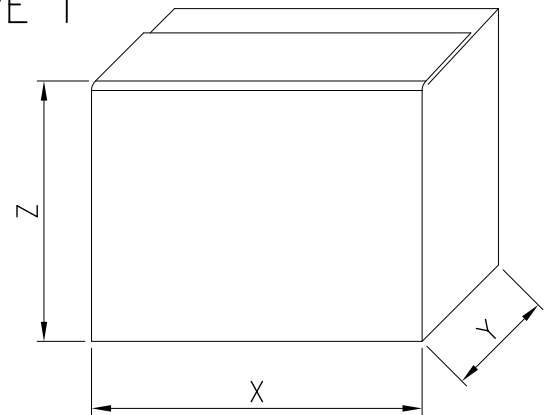

TYPE 2

