



EBARA

CS1571EB

EBARA PENTAM Plastic Pumps

Model FPS

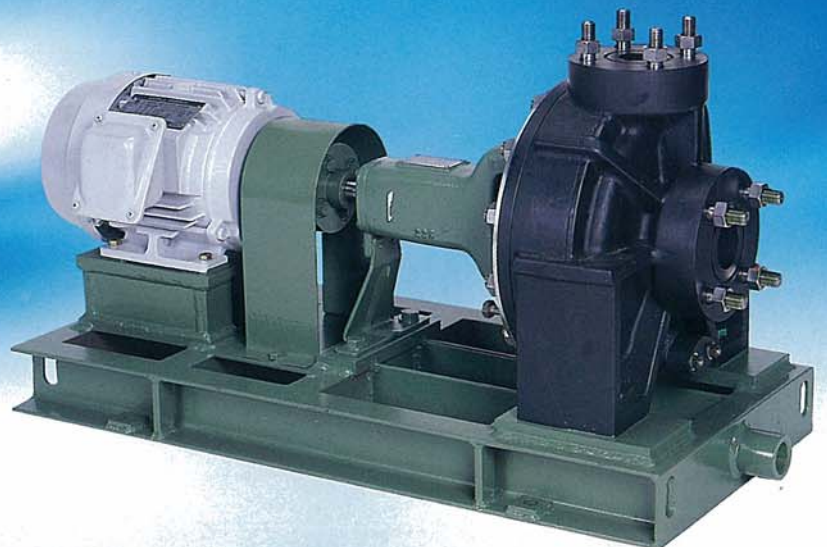

Newly developed plastic pumps: the shape of things to come

Unlike metal, plastic is highly resistant to corrosion by acid, seawater and other liquids. However, it also has drawbacks such as its low strength and low resistance to heat, as well as technical difficulties associated with its formation. But by utilizing the Nippon Zeon Co.Ltd.'s PENTAM plastic, Ebara has overcome these drawbacks and succeeded in developing a high performance plastic pump with excellent durability.

Applications

Intake, supply and circulation of seawater;
transfer and circulation of corrosive chemical liquids;
transfer and circulation of hot spring water.

Features

● High efficiency

The pump consumes 20-30% less energy than our earlier plastic pumps, thanks to high efficiency (comparable to cast metal pumps) and the ability to be built to particular user requirements.

● Low NPSH

The low NPSH design stresses suction performance; the pump can cope with large variation in suction height.

● Easily disposable

Absence of fiberglass reinforcement in the plastic material means the pump can be disposed of by incineration. - An environment-protecting feature.

● Excellent resistance to corrosion

Highly resistant to acids, seawater and other liquids that corrode stainless steel.

● Ample strength and durability

Thanks to thickness 3 times thicker than cast iron thickness, plus foot support structure, the pump can bear heavy piping loads and is highly durable in terms of deterioration and abrasion.

● Excellent resistance to abrasion

The plastic's highly elastic properties, together with the absence of fiberglass reinforcement, mean high resistance to abrasion by sand or slurry. Resistance to cavitation-corrosion is also excellent.

● Heat hardening plastic

Since the plastic has the property of hardening in response to heat, the pump will not seize as a result of friction heat generated by rotor contact or by foreign matter.

● Easy maintenance

Easy maintenance thanks to lightweight, back-pull-out construction that permits disassembly of major components without removing the piping.

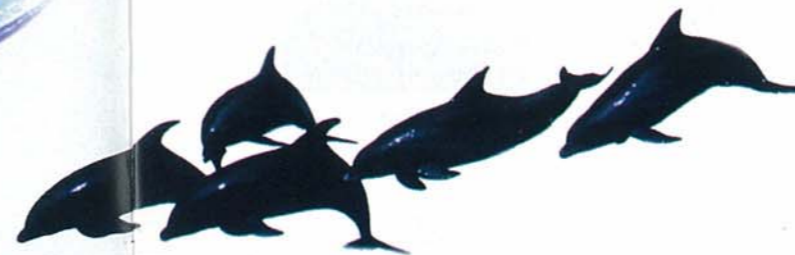
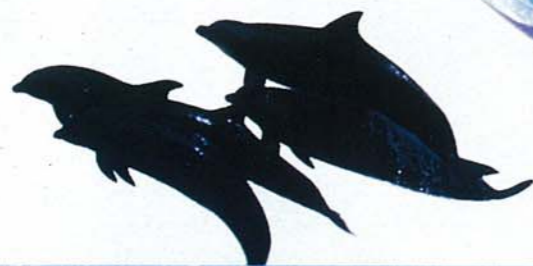
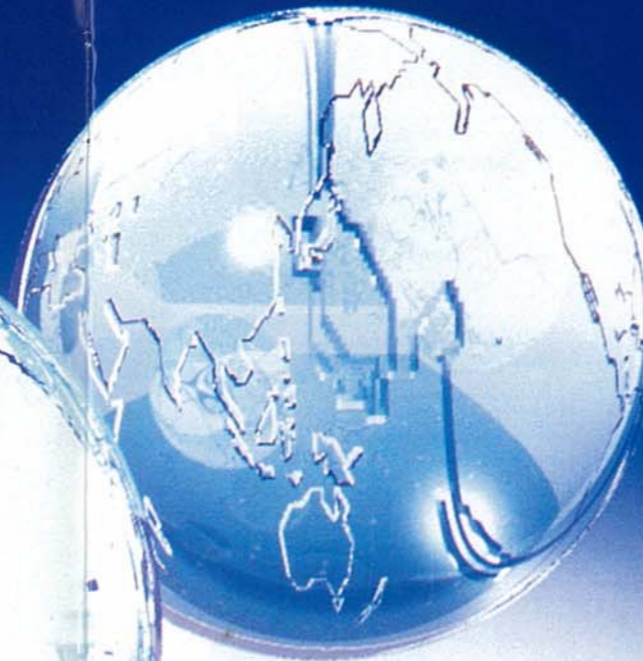

Specifications

Standard specifications

		Seawater spec.	Hot spring water spec.	Chemical liquid spec.
Liquid	Name Temperature	Seawater, circulating seawater -5 ~ 80°C	Hot spring water -5 ~ 80°C	Acids and chlorides -5 ~ 80°C
Allowable suction pressure		** Gauge pressure 0.2MPa (2.0kgf/cm ²)		
Max. working pressure		See dimensions drawing		
Req.NPSH		See selection chart		
Construction	Impeller	Semi-open type	Semi-open type	Semi-open type
	Gland cover	Gland packing	Gland packing	Outside mechanical seal
	Flashing	Self-flashing	Self-flashing	Quenching
	Bearing	Ball bearings	Ball bearings	Ball bearing
	Bearing lubrication	Grease packed	Grease packed	Grease packed
Flange		JIS10K or equivalent	JIS10K or equivalent	JIS10K or equivalent
Materials	Casing	PDCPD*1	PDCPD*1	PDCPD*1
	Gland cover	PDCPD/SUS304	PDCPD/SUS304	PDCPD/SUS304
	Impeller	PDCPD/SUS316	PDCPD/SUS316	PDCPD/SUS316
	Shaft	SUS403	SUS403	SUS403
	Shaft sleeve	SUS316	SUS316	PDCPD
	Gland packing	P#4506L*2	P#4506L*2	—
	Mechanical seal	—	—	SiC/ carbon -SUS316
	O-ring	NBR*3	NBR*3	FPM*4
	Common base	SS400	SS400	SS400
Anchor bolts	SUS304	SUS304	SUS304	
Painting	Bearing, base, etc. PENTAM parts	Chlorinated rubber paint Unpainted	Chlorinated rubber paint Unpainted	Chlorinated rubber paint Unpainted
	Installation location	Indoors/outdoors	Indoors/outdoors	Indoors/outdoors

Optional specifications

		Seawater spec.	Hot spring water spec.	Chemical liquid spec.
Construction	Flashing	External flashing	External flashing	—
	Bearing lubrication	Oil bath	Oil bath	Oil bath
Materials	Shaft	SUS316	SUS316	SUS316
	Shaft sleeve	Titanium	Titanium	—
	Gland packing	P#4507L*5	P#4507L*5	—
	Mechanical seal	—	—	SiC/SiC-SUS316
Common base	SUS304	SUS304	SUS304	
Painting	Bearing, base, etc. PENTAM parts	Acrylic urethane resin paint	Epoxy resin paint Acrylic urethane resin paint	Epoxy resin paint Acrylic urethane resin paint

Material symbols:

*1: PDCPD: Dicyclopentadiene (formal name of PENTAM)

*2: P#4506L: PTFE resin-impregnated alamide packing

(symbol for Nippon Pillar product, for use with seawater, oil, weak acids/alkalis)

*3: NBR: Nitrile rubber (oil-resistant synthetic rubber)

*4: FPM: Fluororubber (acid-resistant synthetic rubber)

*5: P#4507L: Graphite-filled PTFE fiber packing (acid- and alkali- resistant)

Accessories

Standard accessories

Common base	1
Anchor bolt	1 set
Coupling	1 set
Coupling guard	1

Optional accessories

- Special flange for gauge (AV gauge flange made of PVC)
- Gauges

Sectional Drawings

For seawater spec. or hot spring water spec.

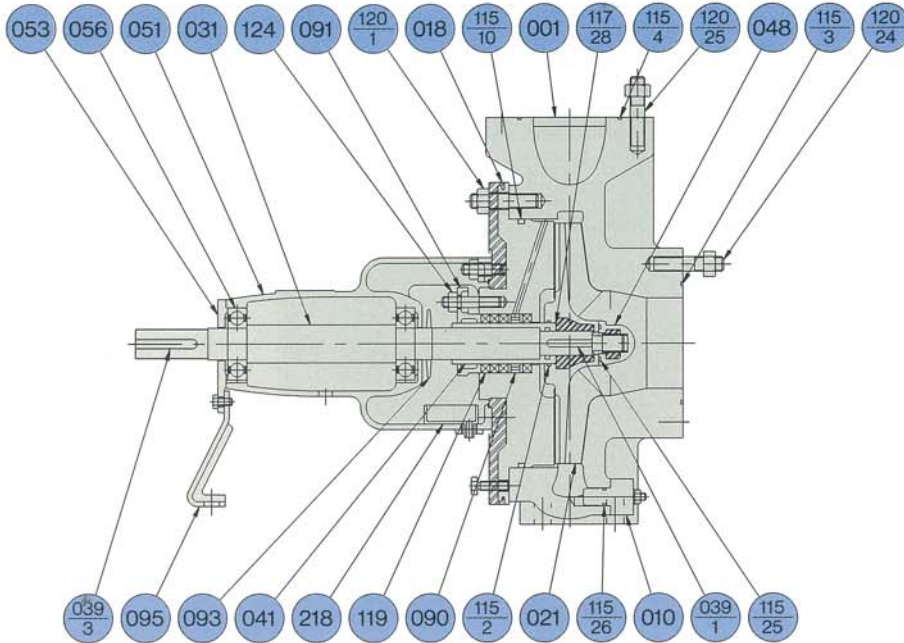

218	Drain pan	PVC	1
124	Gland bolt	SUS316	2
120-25	Bolt	SUS403	1set
120-24	Bolt	SUS403	1set
120-1	Bolt	SUS403	1set
119	Gland packing	P#4506L	4
117-28	Adjusting seat	V#7010-2	1
115-26	O-ring	NBR	1
115-25	O-ring	NBR	1
115-10	O-ring	NBR	1
115-4	O-ring	NBR	1
115-3	O-ring	NBR	1
115-2	O-ring	NBR	1
095	Stay	SS/ plated	1
093	Deflector	Rubber/EPDM	1
091	Gland	SCS14	1
090	Seal ring	SUS316	1
056	Ball bearing		2
053	Bearing cover	FC150	1
051	Bearing housing	FC150	1
048	Impeller nut	PDCPD/SUS316	1
041	Packing sleeve	SUS316	1
039-3	Key	S50C	1
039-1	Key	SUS316	1
031	Shaft	SUS403	1
021	Impeller	PDCPD/SUS316	1
018	Gland cover	PDCPD/SUS304	1
010	Drain cover	PDCPD	1
001	Casing	PDCPD	1
Part No.	Part name	Material	Quantity

For chemical liquid spec.

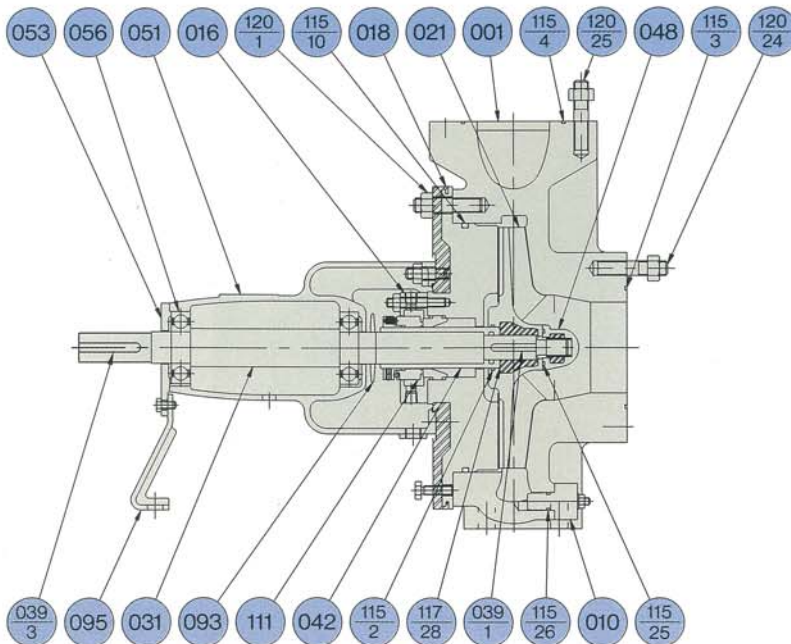

120-25	Bolt	SUS403	1set
120-24	Bolt	SUS403	1set
120-1	Bolt	SUS403	1set
117-28	Adjusting seat	V#7010-2	1
115-26	O-ring	FPM	1
115-25	O-ring	FPM	1
115-10	O-ring	FPM	1
115-4	O-ring	FPM	1
115-3	O-ring	FPM	1
115-2	O-ring	FPM	1
111	Mechanical seal		1set
095	Stay	SS/ plated	1
093	Deflector	Rubber/EPDM	1
056	Ball bearing		2
053	Bearing cover	FC150	1
051	Bearing housing	FC150	1
048	Impeller nut	PDCPD/SUS316	1
042	Mechanical seal sleeve	PDCPD	1
039-3	Key	S50C	1
039-1	Key	SUS316	1
031	Shaft	SUS403	1
021	Impeller	PDCPD/SUS316	1
018	Gland cover	PDCPD/SUS304	1
016	Mechanical seal cover	SUS316	1
010	Drain cover	PDCPD	1
001	Casing	PDCPD	1
Part No.	Part name	Material	Quantity

Selection Charts

50 Hz 4 pole (synchronous speed: 1500 min⁻¹)

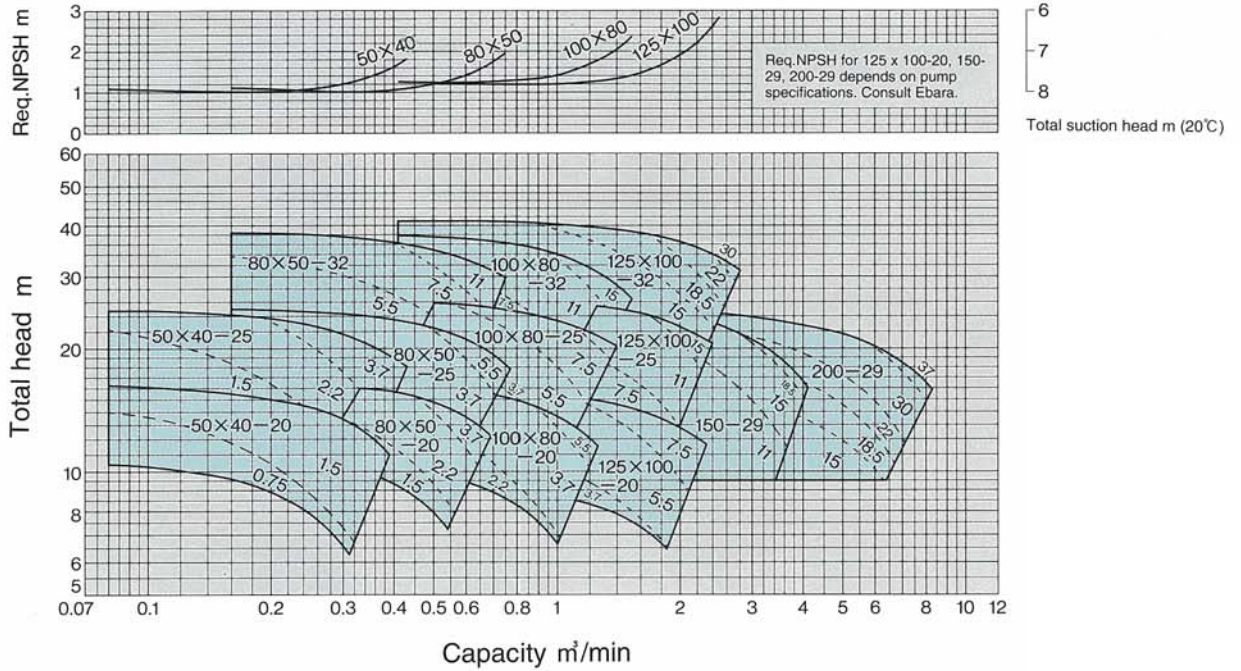

50 Hz 6 pole (synchronous speed: 1000 min⁻¹)

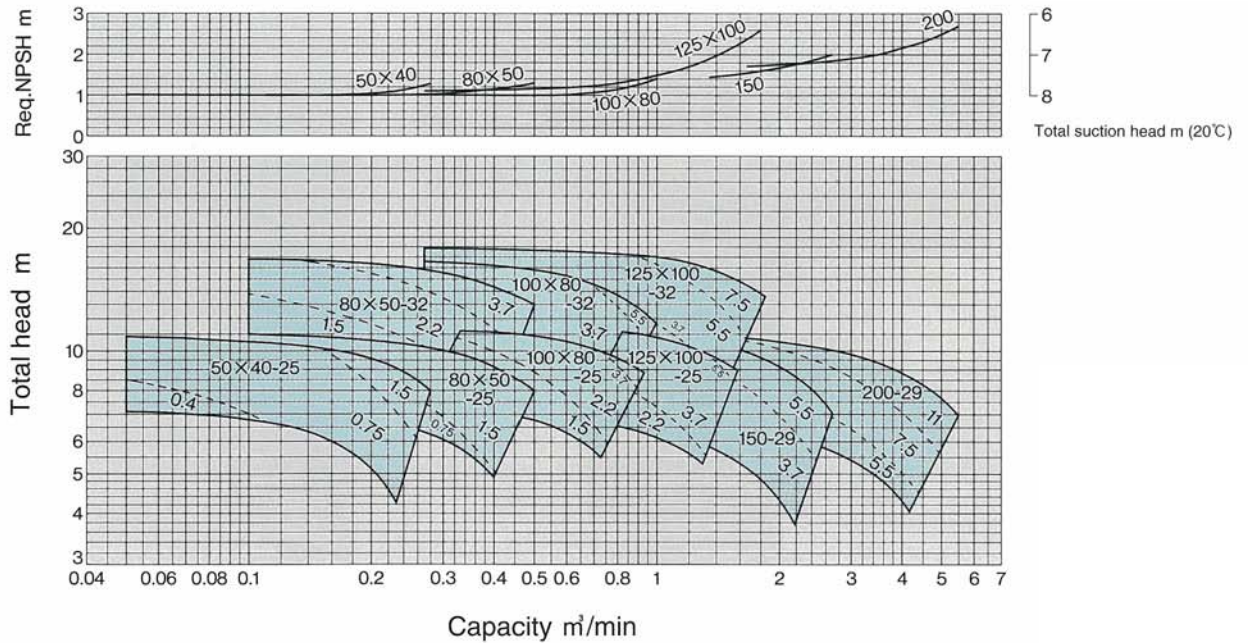

Note: 1. NPSH varies with pump model. Consult applicable performance curves to determine NPSH.
 2. Figures inside the broken lines are motor output with liquid density of 1.03 kg/l (seawater).

60 Hz 4 pole (synchronous speed: 1800 min⁻¹)

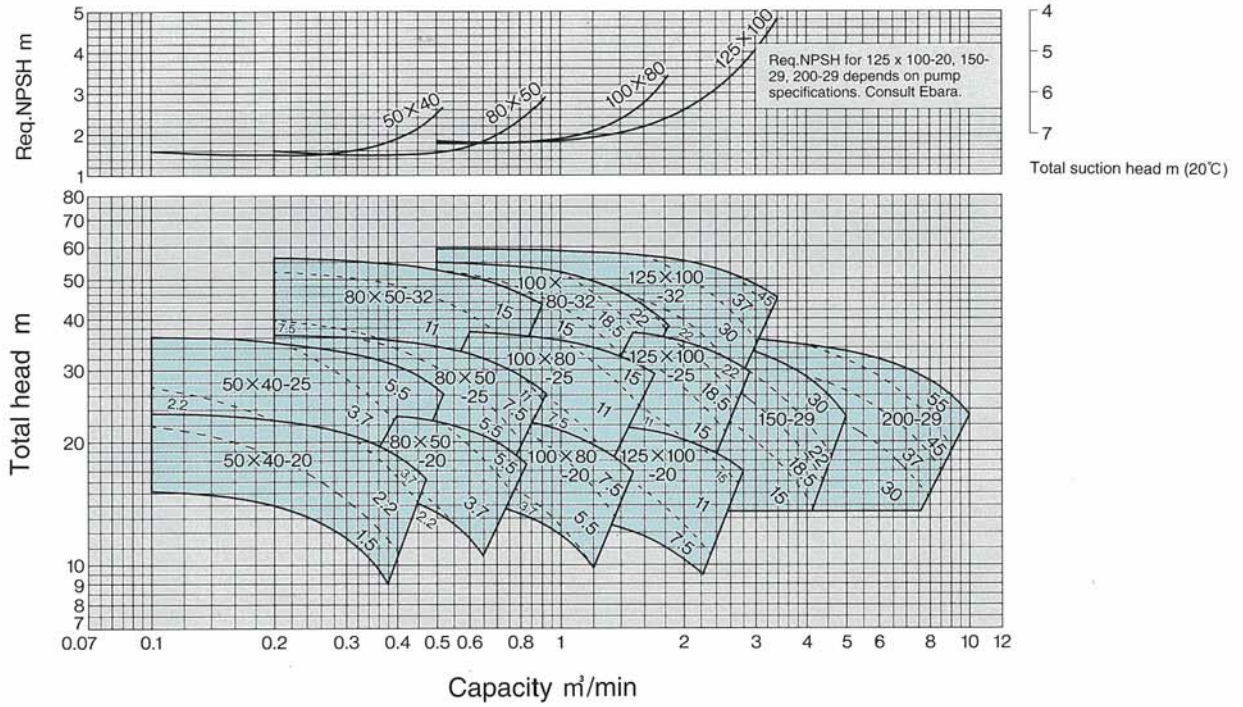

60 Hz 6 pole (synchronous speed: 1200 min⁻¹)

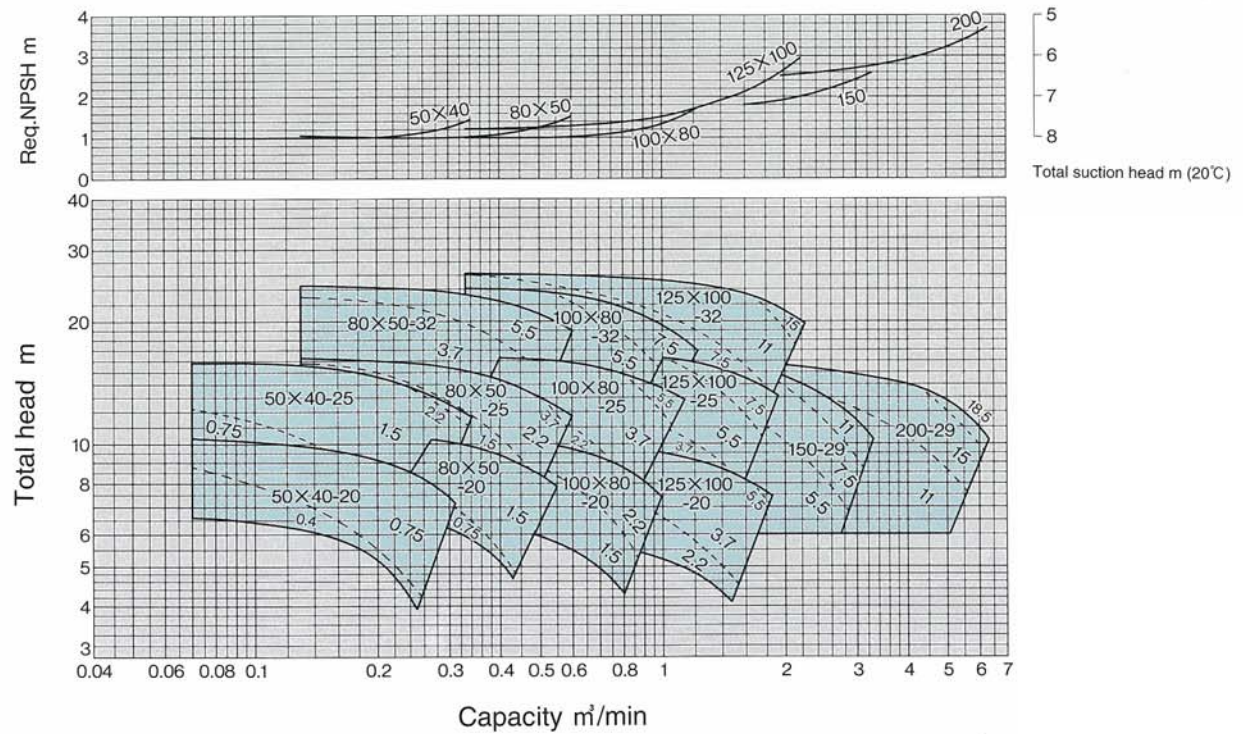

Note: 1. NPSH varies with pump model. Consult applicable performance curves to determine NPSH.
 2. Figures inside the broken lines are motor output with liquid density of 1.03 kg/l (seawater).

Dimensions

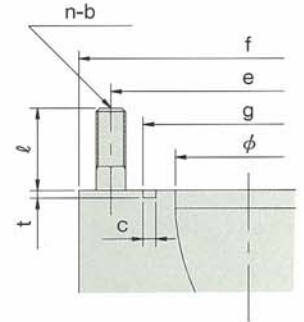
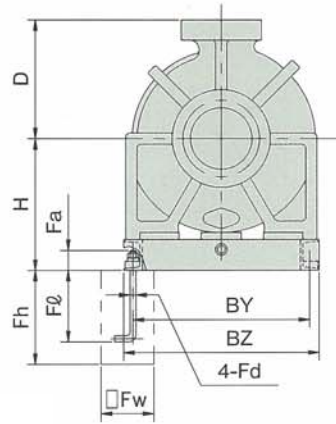
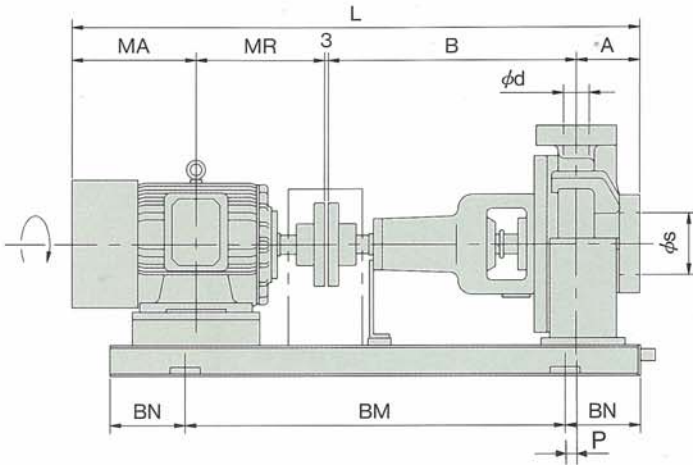

Flange (JIS10K or equivalent) Units: mm

φ	f	e	g	c	t	n	b	ℓ
40	140	105	70	4.1	2.4	4	M16	40
50	155	120	80	4.1	2.4	4	M16	40
80	185	150	115	4.1	2.4	8	M16	45
100	210	175	135	4.1	2.4	8	M16	45
125	250	210	160	7.5	4.6	8	M20	50
150	280	240	190	7.5	4.6	8	M20	50
200	330	290	240	7.5	4.6	12	M20	50

*Flange bolt length ℓ can be altered to your specification.

Units: mm

Model	Motor				Pump										Common base				Anchor bolts					Total weight (mass) kg	Max. working pressure (at 80°C) gauge pressure kgf/cm ² (MPa)		
	Output kW 4 pole 5 pole	Frame No.	MA	MR	Weight (mass) kg	φs	φd	A	B	D	H	L	P	Weight (mass) kg	BM	BN	BY	BZ	Weight (mass) kg	Fd	Fa	Fℓ	Fh			Fw	
50 × 40FPSM20	0.75	0.4	80M	133	140	17	50	40	100	385	180	255	761	30	33	520	150	360	400	45	M12	34	216	250	110	95	5.0 (0.490)
	1.5	0.75	90L	158.5	168.5	29	50	40	100	385	180	255	815	30	33	520	150	360	400	45	M12	34	216	250	110	107	
	2.2	—	100L	173	193	35	50	40	100	385	180	255	854	30	33	520	150	360	400	45	M12	34	216	250	110	113	
	3.7	—	112M	183	200	48	50	40	100	385	180	255	871	30	33	520	150	360	400	45	M12	34	216	250	110	126	
50 × 40FPSM25	—	0.4	80M	133	140	17	50	40	100	385	225	275	761	30	43	520	150	360	400	55	M12	34	216	250	110	115	6.0 (0.588)
	1.5	0.75	90L	158.5	168.5	29	50	40	100	385	225	275	815	30	43	520	150	360	400	50	M12	34	216	250	110	122	
	2.2	1.5	100L	173	193	35	50	40	100	385	225	275	854	30	43	520	150	360	400	50	M12	34	216	250	110	128	
	3.7	2.2	112M	183	200	48	50	40	100	385	225	275	871	30	43	520	150	360	400	45	M12	34	216	250	110	136	
	5.5	—	132S	210	239	74	50	40	100	385	225	275	937	30	43	620	150	360	400	50	M12	34	216	250	110	167	
80 × 50FPSM20	1.5	0.75	90L	158.5	168.5	29	80	50	100	385	200	255	815	30	34	520	150	360	400	45	M12	34	216	250	110	108	5.0 (0.490)
	2.2	1.5	100L	173	193	35	80	50	100	385	200	255	854	30	34	520	150	360	400	45	M12	34	216	250	110	114	
	3.7	—	112M	183	200	48	80	50	100	385	200	255	871	30	34	520	150	360	400	45	M12	34	216	250	110	127	
	5.5	—	132S	210	239	74	80	50	100	385	200	255	937	30	34	620	150	360	400	45	M12	34	216	250	110	153	
80 × 50FPSM25	—	0.75	90L	158.5	168.5	29	80	50	125	480	225	275	935	55	51	620	150	360	400	50	M12	34	216	250	110	130	6.0 (0.588)
	—	1.5	100L	173	193	35	80	50	125	480	225	275	974	55	51	620	200	360	400	55	M12	34	216	250	110	141	
	3.7	2.2	112M	183	200	48	80	50	125	480	225	275	991	55	51	620	200	360	400	50	M12	34	216	250	110	149	
	5.5	3.7	132S	210	239	74	80	50	125	480	225	275	1057	55	51	620	200	360	400	55	M12	34	216	250	110	180	
	7.5	—	132M	229	258	94	80	50	125	480	225	275	1095	55	51	620	200	360	400	55	M12	34	216	250	110	200	
	11	—	160M	280	323	126	80	50	125	480	225	275	1211	55	51	720	200	360	400	55	M12	34	216	250	110	232	
80 × 50FPSM32	—	1.5	100L	173	193	35	80	50	125	480	280	320	974	55	63	620	200	460	500	70	M12	34	216	250	110	168	9.0 (0.882)
	—	2.2	112M	183	200	48	80	50	125	480	280	320	991	55	63	620	200	460	500	65	M12	34	216	250	110	176	
	5.5	3.7	132S	210	239	74	80	50	125	480	280	320	1057	55	63	620	200	460	500	60	M12	34	216	250	110	197	
	7.5	5.5	132M	229	258	94	80	50	125	480	280	320	1095	55	63	620	200	460	500	60	M12	34	216	250	110	217	
	11	—	160M	280	323	126	80	50	125	480	280	320	1211	55	63	720	200	460	500	65	M12	34	216	250	110	254	
	15	—	160L	302	345	152	80	50	125	480	280	320	1255	55	63	820	200	460	500	65	M12	34	216	250	110	280	

Units: mm

Model	Motor						Pump								Common base					Anchor bolts					Total weight (mass) kg	Max. working pressure (at 80°C) gauge pressure kgf/cm² (MPa)	
	Output kW		Frame No.	MA	MR	Weight (mass) kg	ϕ s	ϕ d	A	B	D	H	L	P	Weight (mass) kg	BM	BN	BY	BZ	Weight (mass) kg	Fd	Fa	F ℓ	Fh			Fw
	4 pole	6 pole																									
100 × 80FPSM20	2.2	1.5	100L	173	193	35	100	80	100	480	225	275	949	30	45	620	150	360	400	50	M12	34	216	250	110	130	5.0 (0.490)
	3.7	2.2	112M	183	200	48	100	80	100	480	225	275	966	30	45	620	150	360	400	50	M12	34	216	250	110	143	
	5.5	—	132S	210	239	74	100	80	100	480	225	275	1032	80	45	620	200	360	400	55	M12	34	216	250	110	174	
	7.5	—	132M	229	258	94	100	80	100	480	225	275	1070	80	45	620	200	360	400	55	M12	34	216	250	110	194	
100 × 80FPSM25	—	1.5	100L	173	193	35	100	80	125	480	250	295	974	55	54	620	200	460	500	55	M12	34	216	250	110	144	6.0 (0.588)
	3.7	2.2	112M	183	200	48	100	80	125	480	250	295	991	55	54	620	200	460	500	55	M12	34	216	250	110	157	
	5.5	3.7	132S	210	239	74	100	80	125	480	250	295	1057	55	54	620	200	460	500	55	M12	34	216	250	110	183	
	7.5	5.5	132M	229	258	94	100	80	125	480	250	295	1095	55	54	620	200	460	500	55	M12	34	216	250	110	203	
	11	—	160M	280	323	126	100	80	125	480	250	295	1211	55	54	720	200	460	500	60	M12	34	216	250	110	240	
	15	—	160L	302	345	152	100	80	125	480	250	295	1255	55	54	820	200	460	500	60	M12	34	216	250	110	266	
100 × 80FPSM32	—	3.7	132S	210	239	74	100	80	125	535	280	320	1112	55	81	720	200	460	500	60	M12	34	216	250	110	215	9.0 (0.882)
	7.5	5.5	132M	229	258	94	100	80	125	535	280	320	1150	55	81	720	200	460	500	60	M12	34	216	250	110	235	
	11	7.5	160M	280	323	126	100	80	125	535	280	320	1266	55	81	820	200	460	500	70	M12	34	216	250	110	277	
	15	—	160L	302	345	152	100	80	125	535	280	320	1310	55	81	820	200	460	500	70	M12	34	216	250	110	303	
	18.5/22	—	180M	325	351.5	195	100	80	125	535	280	320	1339.5	55	81	820	200	460	500	70	M12	34	216	250	110	346	
	30	—	180L	344	370.5	210	100	80	125	535	280	320	1377.5	80	81	890	225	460	500	75	M12	34	216	250	110	366	
125 × 100FPSM20	3.7	2.2	112M	183	200	48	125	100	125	480	280	295	991	55	55	620	200	460	500	55	M12	34	216	250	110	158	5.0 (0.490)
	5.5	3.7	132S	210	239	74	125	100	125	480	280	295	1057	55	55	620	200	460	500	55	M12	34	216	250	110	184	
	7.5	5.5	132M	229	258	94	125	100	125	480	280	295	1095	55	55	620	200	460	500	55	M12	34	216	250	110	204	
	11	—	160M	280	323	126	125	100	125	480	280	295	1211	55	55	720	200	460	500	60	M12	34	216	250	110	241	
	15	—	160L	302	345	152	125	100	125	480	280	295	1255	55	55	820	200	460	500	60	M12	34	216	250	110	267	
	—	2.2	112M	183	200	48	125	100	140	535	280	320	1061	40	76	620	200	460	500	55	M12	34	216	250	110	179	
125 × 100FPSM25	—	3.7	132S	210	239	74	125	100	140	535	280	320	1127	40	76	720	200	460	500	60	M12	34	216	250	110	210	6.0 (0.588)
	7.5	5.5	132M	229	258	94	125	100	140	535	280	320	1165	40	76	720	200	460	500	60	M12	34	216	250	110	230	
	11	7.5	160M	280	323	126	125	100	140	535	280	320	1281	40	76	820	200	460	500	65	M12	34	216	250	110	267	
	15	—	160L	302	345	152	125	100	140	535	280	320	1325	40	76	820	200	460	500	65	M12	34	216	250	110	293	
	18.5/22	—	180M	325	351.5	195	125	100	140	535	280	320	1354.5	40	76	820	200	460	500	65	M12	34	216	250	110	336	
	—	3.7	132S	210	239	74	125	100	140	535	315	345	1127	40	88	720	200	500	540	75	M12	34	216	250	110	237	
125 × 100FPSM32	—	5.5	132M	229	258	94	125	100	140	535	315	345	1165	40	88	720	200	500	540	75	M12	34	216	250	110	257	9.0 (0.882)
	—	7.5	160M	280	323	126	125	100	140	535	315	345	1281	40	88	820	200	500	540	70	M12	34	216	250	110	284	
	15	11	160L	302	345	152	125	100	140	535	315	345	1325	40	88	820	200	500	540	70	M12	34	216	250	110	310	
	18.5/22	15	180M	325	351.5	195	125	100	140	535	315	345	1354.5	40	88	820	200	500	540	65	M12	34	216	250	110	348	
	30	—	180L	344	370.5	210	125	100	140	535	315	345	1392.5	65	88	890	225	500	540	70	M12	34	216	250	110	368	
	37/45	—	200L	377	425.5	350	125	100	140	535	315	345	1480.5	65	88	890	225	500	540	85	M12	34	216	250	110	523	
150FPSM29	—	3.7	132S	210	239	74	150	150	140	555	355	400	1147	40	75	720	200	590	640	100	M16	40	275	315	130	249	7.0 (0.686)
	—	5.5	132M	229	258	94	150	150	140	555	355	400	1185	40	75	720	200	590	640	100	M16	40	275	315	130	269	
	11	7.5	160M	280	323	126	150	150	140	555	355	400	1301	65	75	830	225	590	640	95	M16	40	275	315	130	296	
	15	11	160L	302	345	152	150	150	140	555	355	400	1345	65	75	830	225	590	640	95	M16	40	275	315	130	322	
	18.5/22	—	180M	325	351.5	195	150	150	140	555	355	400	1374.5	65	75	830	225	590	640	95	M16	40	275	315	130	365	
	30	—	180L	344	370.5	210	150	150	140	555	355	400	1412.5	65	75	830	225	590	640	95	M16	40	275	315	130	380	
200FPSM29	—	5.5	132M	229	258	94	200	200	160	669	450	475	1319	45	135	830	225	700	750	70	M16	40	275	315	130	299	6.0 (0.588)
	—	7.5	160M	280	323	126	200	200	160	669	450	475	1435	70	135	920	250	700	750	80	M16	40	275	315	130	341	
	15	11	160L	302	345	152	200	200	160	669	450	475	1479	70	135	920	250	700	750	80	M16	40	275	315	130	367	
	18.5/22	15	180M	325	351.5	195	200	200	160	669	450	475	1508.5	70	135	920	250	700	750	80	M16	40	275	315	130	410	
	30	18.5	180L	344	370.5	210	200	200	160	669	450	475	1546.5	70	135	920	250	700	750	80	M16	40	275	315	130	425	
	37/45	—	200L	377	425.5	350	200	200	160	669	450	475	1634.5	70	135	1000	250	700	750	85	M16	40	275	315	130	570	
	55	—	225S	388	432	400	200	200	160	669	450	475	1652	70	135	1000	250	700	750	85	M16	40	275	315	130	620	

What is "PENTAM"?

"PENTAM" is the name given to plastic formed using a forming technique called ZEON-RIM that was developed by Nippon Zeon Co.,Ltd.

RIM (Reaction Injection Molding) involves injecting 2 (or sometimes more) low-molecular weight, low-viscosity liquids into a mold, while mixing them at the same time; the chemical reactions of the liquids inside the mold result in a high polymer molded product.

ZEON-RIM, which uses dicyclopentadiene (a C5 distillate of petroleum) and its derivatives as main materials, permits molding at much lower temperature and viscosity than conventional RIM, and can be used to create molded products with physical properties similar to standardized engineering plastics.

Among PENTAM's many features are:

- 1) It can be molded into as many different shapes as cast metals.
- 2) It can easily be molded into large-size, thick-walled products.
- 3) It is robust, with excellent resistance to impact.
- 4) It has low water absorption, giving it excellent dimensional stability.
- 5) It has excellent resistance to chemicals, suiting it to anti-corrosion applications.

PENTAM chemical resistance data

Liquid		Concentration by wt. (%)	Temperature °C	Criterion
Inorganic	Sulfuric acid	70	80	◎
	Hydrochloric acid	36	80	○
	Nitric acid	40	25	○
	Phosphoric acid	80	80	◎
Organic	Hydrofluoric acid	10	25	◎
	Formic acid	10	80	◎
	Acetic acid	75	80	◎
Alkali	Aqueous ammonia	10	80	◎
	Sodium hydroxide	40	80	◎
	sodium carbonate	20	80	◎
Chlorides	Sodium chloride	26	80	◎
	Ferrous chloride	28	80	◎
	Ferric chloride	48	80	◎
	Potassium chloride	21	80	◎
	Aluminum chloride	100	80	◎
	Cupric sulfate	16	80	◎
Decolorants	Aluminum sulfate	10	30	◎
	Aqueous hydrogen peroxide	30	25	◎
	Chlorine water	Saturated	80	○
	Calcium hypochlorite	5	25	◎
	Hypochlorite soda	12	40	◎
Alcohols	Methyl alcohol	100	80	◎
	Ethyl alcohol	100	80	◎
Solvents	Acetone	100	25	×
	Carbon tetrachloride	100	25	×
	Benzene	100	25	×
	Toluene	100	25	×
	Tetrahydrofuran	100	25	×
	Aniline	100	25	×
Oils	Gasoline	100	25	×
	Kerosene	100	25	×
	Insulating oil	100	25	×
	Lubricant oil	100	80	◎
	Castor oil	100	80	◎
	Linseed oil	100	80	◎
	Silicone oil	100	80	◎

Criterion: ◎Can be pumped if concentration does not exceed 2%; ○Can be pumped (with certain difficulty) if concentration is 2-5%;
 × Cannot be pumped if concentration exceeds 5%Weight change rate over 7 days at 80°C, sample size: thickness 3-4mm, 40mm square

PENTAM abrasion resistance

PENTAM materials have excellent abrasion resistance compared to regular FRP and cast iron. The graph below shows the results of abrasive tests of various materials.

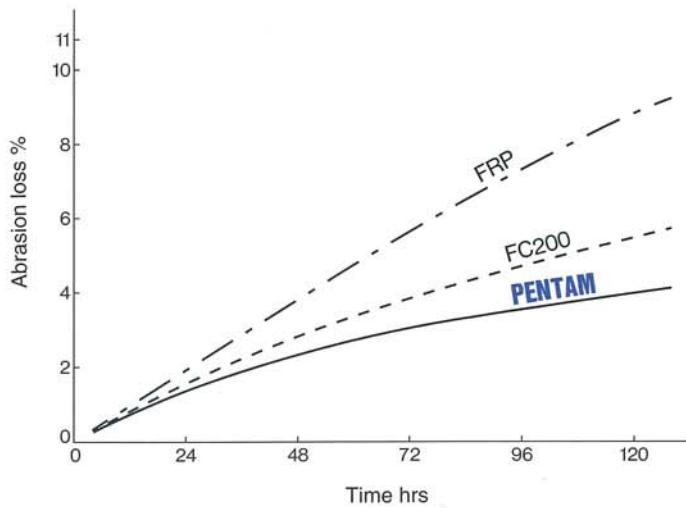

1. Test method: Test piece measuring 55mm long by 18mm wide by 5mm thick were rotated inside the test liquid using a stirrer, and the abrasion loss was measured repeatedly at a given time interval.
2. Stirrer rotation speed: 265 min⁻¹
3. Test liquid: 5 l fresh water + 6 kg grade 4 quartz sand
4. Materials tested: PENTAM
FRP (unsaturated polyester)
FC200 (cast iron)

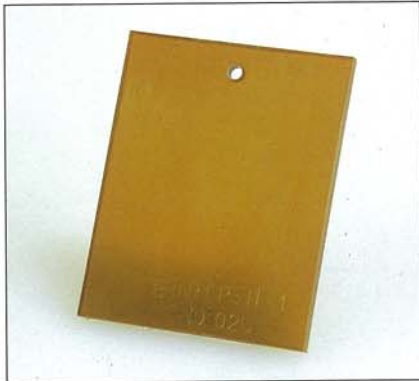

Test piece

The chemical resistance data on the previous page are intended as guidelines for material selection. For precise material evaluation that reflects his use environment, the user is recommended to carry out a soak test on a test piece.



Equipment delivered to the Miyazaki Prefecture Fish Farming Association



EBARA CORPORATION

**International Division
OVERSEAS OFFICE
Scotland Branch Office
Singapore Branch Office
Seoul Branch Office
Beijing Office**

**Bangkok Office
Jakarta Office
Manila Office
Taipei Office
Hanoi Office**

OVERSEAS COMPANIES

**Ebara International Corporation
Ebara Industrias Mecanicas e Comercio Ltda.
Ebara UK Limited
Ebara Italia S.p.A.
Ebara Espana Bombas S.A.
Ebara Engineering Singapore Pte. Ltd.
Ebara (Thailand) Limited**

Asahi Bldg., 6-7, Ginza 6-chome, Chuo-ku, Tokyo, 104 Japan

3 Adam Square, Brucefield Industrial Estate, Livingston, West Lothian EH 54 9DE, UK
No.67 Tuas Avenue 1, Jurong, Singapore 2263
11th Floor, Dongwon Bldg., 946-14, Daichi-dong, Kangnam-ku, Seoul, Republic of Korea
521 Beijing Fortune Bldg., Dong Sanhuan Bei-Lu, Chaoyang District, Beijing 100004,
People's Republic of China

3rd Floor, ACME Bldg., 125 Phetchburi Rd., Rajthevee, Bangkok 10400, Thailand
c/o Indobara Bahana, Jl. Gunung Sahari, Raya 57G, Jakarta Pusat, Indonesia
10th Floor, Sage House, 110 Herrera Street, Legaspi Village, Metro Manila, Philippines
Room 1406-A, Chia Hsin Bldg., No. 96, Sec. 2, Chung Shang N. Rd., Taipei, 10449, Taiwan
38 Phu Dong Thien Vuong St., Hanoi, Vietnam

350 Salomon Circle, Sparks, NV 89434 U.S.A.
Rua Joaquim Marques de Figueiredo 2-3, Bauru S.P., Brazil
2 Ariel Way, Heathrow Causeway, Great South West Road, Hounslow, Middlesex, TW4 6JS, UK
Via Campo Sportivo 30, 38023, Cles (Trento), Italy
Poligonó Las Arenas, C/Alameda 1, 28320, Pinto (Madrid), Spain
NO.1 Tuas Link 2, Singapore 638550
3 Flr. ACME Bldg., 125 Petchburi Road, Rajthevee, Bangkok, 10400 Thailand

Phone
03-3289-6111

44-1506-460-232
65-862-3536
82-2-538-7031
86-10-501-7541

66-2-216-4935/4936
62-21-571-0213
63-2-816-7524
886-2-567-1310
84-4-8263601

1-702-356-2796
55-142-30-2444
44-181-577-1331
39-463-660411
34-1-692-3630
65-862-3536
66-2-216-4935