



Units with two horizontal dual impeller pumps with cast iron hydraulic parts.

PUMP FEATURES

FIELD OF USE

- Maximum working pressure:
 - 6 bar for CDA 0.75 - 1.00
 - 10 bar for the rest of the range
- Maximum temperature of the liquid:
 - 40°C for CDA 0.75 - 1.00
 - 90°C for the rest of the range

MATERIALS

- Cast iron pump body
- Mechanical seal in Carbon/Ceramic/NBR
- Impeller:
 - in technopolymer for CDA 0.75 - 1.00
 - in brass for the rest of the range
- Shaft:
 - in AISI 303 for CDA 1.50 - 2.00 - 3.00
 - in AISI 304 for CDA 4.00 - 5.50
 - in AISI 416 for the rest of the range
- Support:
 - in aluminium for CDA 0.75 - 1.00
 - in cast iron for the rest of the range
- Seal housing disc:
 - in AISI 304 for CDA 0.75 - 1.00
 - in cast iron for the rest of the range

TECHNICAL DATA

- Self-ventilated 2 pole asynchronous motor
- Class of insulation F
- Protection rating IP44
- 230V \pm 10% 50Hz, single phase voltage
230/400V \pm 10% 50Hz three phase voltage
- Permanent capacitor inserted and thermo-amperometric protection with automatic reset incorporated for the single phase motor
- Protection under user's responsibility for the three phase version

TYPICAL APPLICATIONS

The base of the group is in galvanised steel as are the manifolds. The discharge manifold is set-up to gather any two vertical type membrane reservoirs; two pressure switches, the electric control panel and a pressure gauge are mounted on it.

On inlet, each electric pump has an isolating valve and a non-return valve, with the possibility of connection to an air supply unit and has another isolating valve in discharge mode.

Protection and control panel with CE mark

- IMQ and VDE marked components
- Very low voltage auxiliary circuit
- Motor switch-on and switch-off are controlled by two pressure switches
- The connection to a float of minimum pressure pressure switch is possible in order to prevent functioning in conditions when there is no suction water
- A device is present that inverts the insertion order of the pumps at every start-up
- Power supply:
 - 230V, 50Hz single phase
 - 400V, 50 Hz three phase
- Direct start-up
- Power circuit protection fuses
- Auxiliary circuit protection fuses
- Protection rating IP 55
- Line main isolating device with door lock
- Aut - 0 - man. switches for each pump
- Reset circuit breaker protection
- Indicator LED:
 - network presence
 - motor running
 - level alarm
 - motor in protection mode (for three phase version only)
- Alarm output set-up
- On request, special version control panels can be used

FUNCTIONING PRINCIPLES

The withdrawal or however the escape of water from the system with the pumps at a standstill, causes the pressure to drop and the consequent closure of the pressure switch contact with highest calibration, which determines start-up of the first electric pump. If the outlet discharge exceeds the flow rate of a pump, the pressure continues to drop until it causes the closure of the contact of the second pressure switch and the start-up of the second pump. The end of the distribution of the reduction of the outlet discharge leads to the pressure in the system rising, with opening of the pressure switch contacts and staggered pumps stops. The inversion of the ignition order of the two motors reduces the number of hourly start-ups of the individual pumps and consequently allows a homogenous use of the same. By connecting a float or minimum pressure pressure switch to the control panel (whether for withdrawal from the primary collection reservoir or from the hydraulic circuit), the most frequent cause of electric pump breakdown is prevented: the lack of water at suction.

2GP CDA range PERFORMANCE CURVES

(according to ISO 9906 Attachment A)

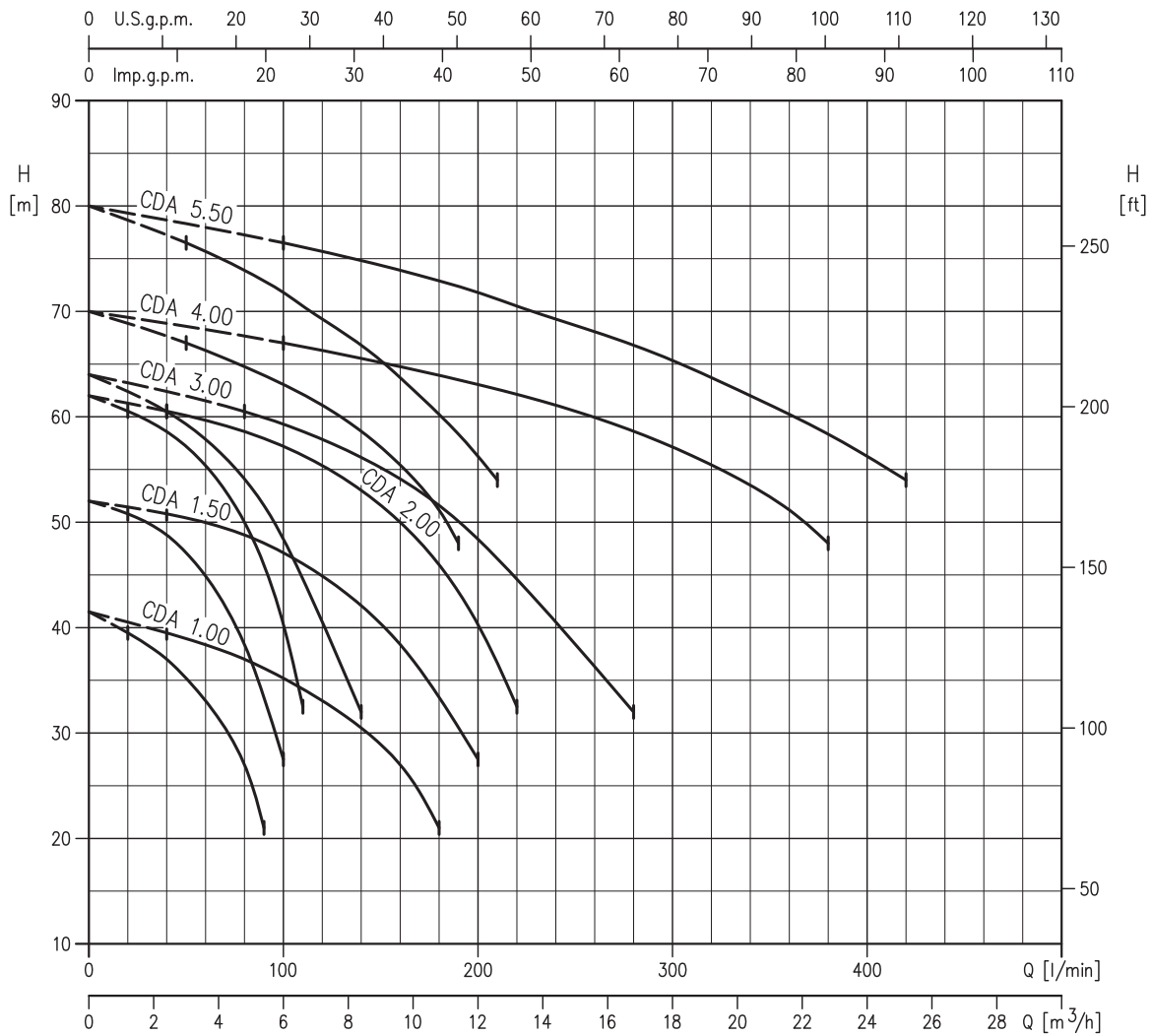

PERFORMANCE TABLE AND ELECTRIC DATA OF THE TWO PUMPS FUNCTIONING SIMULTANEOUSLY

Model		[kW]	Max absorption [A]		Q=Flow rate											
230V single phase	230/400V three-phase		230V single phase	230/400V three-phase	l/min	40	80	100	160	180	200	220	240	280	380	420
				H=Head [m]												
CDA 1,00M	CDA 1,00T	0,75 + 0,75	12,2	4,6	39,5	37,0	35,2	27,0	21,0	-	-	-	-	-	-	-
CDA 1,50M	CDA 1,50T	1,1 + 1,1	18	6,8	50,8	49,0	47,0	38,4	33,4	27,5	-	-	-	-	-	-
CDA 2,00M	CDA 2,00T	1,5 + 1,5	21,6	8,6	60,5	58,5	57,0	50,0	46,5	40,5	32,5	-	-	-	-	-
-	CDA 3,00T	2,2 + 2,2	-	10,2	-	60,5	59,5	54,0	51,5	48,5	44,5	40,5	32,0	-	-	-
-	CDA 4,00T	3 + 3	-	15	-	-	67,0	65,0	64,0	62,5	62,0	61,0	58,0	48,0	-	-
-	CDA 5,50T	4 + 4	-	19	-	-	76,5	74,0	73,0	72,0	70,5	69,0	67,0	58,5	54,0	-

DIMENSIONS

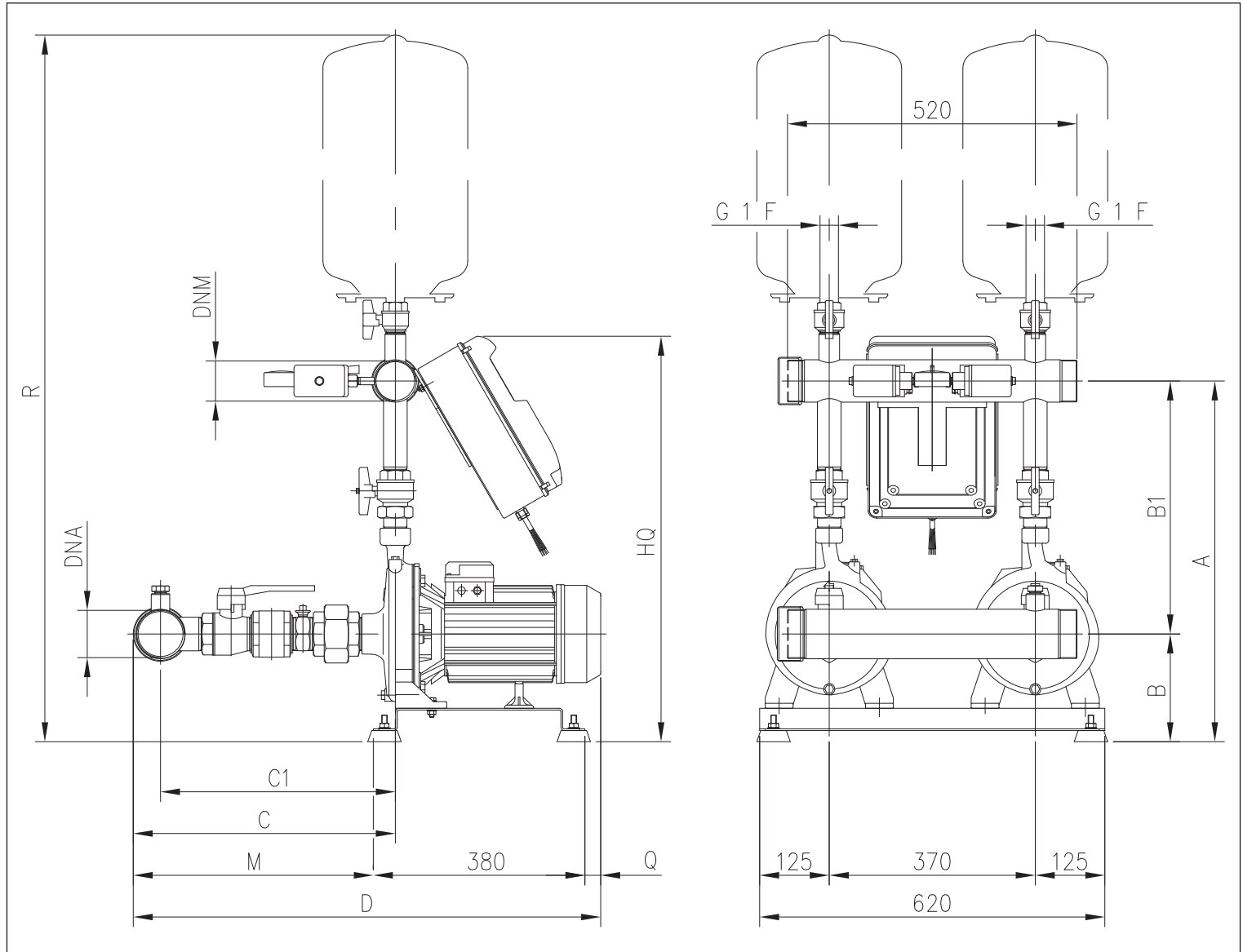

DIMENSIONS TABLE

Model	Dimensions [mm]											Weight [kg]	
	A	B	B1	C	C1	D	DNA	DNM	HQ	M	Q		R
2GP CDA 100	530	160	370	425	395	730	G2	G1½	600	350	-	1135	66,0
2GP CDA 150	565	170	395	420	385	730	G2	G1½	640	340	10	1170	90,0
2GP CDA 200	585	170	415	420	385	745	G2	G2	650	340	25	1185	94,0
2GP CDA 300	625	170	455	490	445	815	G2½	G2½	705	405	30	1245	98,0
2GP CDA 400	635	195	440	475	430	845	G2½	G2½	715	390	75	1255	130,0
2GP CDA 550	635	195	440	475	430	845	G2½	G2½	715	390	75	1255	138,0