

## T 8026 EN

### Type 3244-1 and Type 3244-7 Pneumatic Control Valves

#### Type 3244 Three-way Valve

DIN and ANSI versions



#### Application

Mixing or diverting valve for process engineering and industrial applications

**Valve size** DN 15 to 150 · NPS ½ to 6  
**Pressure rating** PN 10 to 40 · Class 150 and 300  
**Temperatures** -196 to +450 °C · -325 to +842 °F

Type 3244 Three-way Valve with

- Type 3271 Pneumatic Actuator (Fig. 1)
- Type 3277 Pneumatic Actuator (Fig. 2) for integral positioner attachment

Valve body made of

- Cast iron (DIN version only)
- Cast steel
- Cast stainless steel

Undivided valve bonnet

The control valves, designed according to the modular assembly principle, can be equipped with various accessories: Positioners, limit switches, solenoid valves and other accessories according to IEC 60534-6 and NAMUR recommendation (see Information Sheet ▶ T 8350 for more details).

#### Versions

**Standard version** designed for temperatures from -10 to +220 °C (15 to 430 °F) with pneumatic actuator

- **Type 3244-1** (Fig. 1) · Type 3244 Valve with Type 3271 Actuator (see Data Sheet ▶ T 8310-1)
- **Type 3244-7** (Fig. 2) · Type 3244 Valve and Type 3277 Pneumatic Actuator for integral positioner attachment (see Data Sheet ▶ T 8310-1)

#### Further versions

- **Insulating section or bellows seal** · See Technical data
- **Adjustable packing** · Details on request
- **Heating jacket**
- **Additional handwheel** · See Data Sheet ▶ T 8310-1
- **Type 3244-2 Electric Control Valve** · Details on request
- **Type 3244-3 Manually Operated Valve** with Type 3273 Hand-operated Actuator · See Data Sheet ▶ T 8312



**Fig. 1:** Type 3244-1 Pneumatic Control Valve with Type 3271 Actuator



**Fig. 2:** Type 3244-7 Pneumatic Control Valve with Type 3277 Actuator

### Principle of operation (Fig. 3 and Fig. 4)

Depending on the version, the three-way valve can be used for either mixing or diverting service.

In mixing valves, the process media to be mixed enter at valve ports **A** and **B**. The combined flow exits the valve at port **AB** (see Fig. 3). The flow rate from ports **A** or **B** to **AB** depends on the cross-sectional area of flow between the seats and plugs.

In diverting valves, the process medium enters at the valve port **AB** and the partial flows exit at ports **A** and **B** (see Fig. 4).

**Note:** The design of the mixing and diverting valves in sizes DN 15 to 25 (NPS ½ to 1) is identical.

### Fail-safe position

Depending on how the springs are arranged in the pneumatic actuator (► T 8310-1), the valve has two different fail-safe positions effective upon air supply failure.

- **Actuator stem extends:** when the supply air fails, port **B** is closed in mixing valves and port **A** is closed in diverting valves.
- **Actuator stem retracts:** when the supply air fails, port **A** is closed in mixing valves and port **B** is closed in diverting valves.

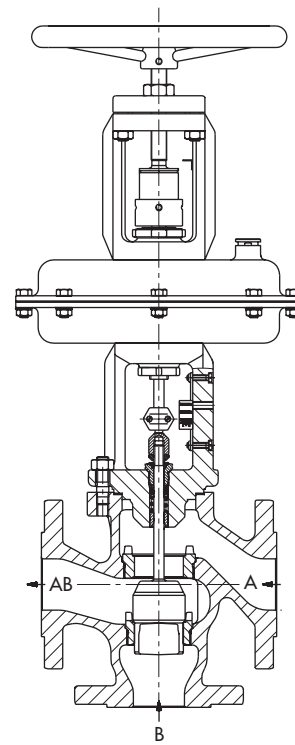

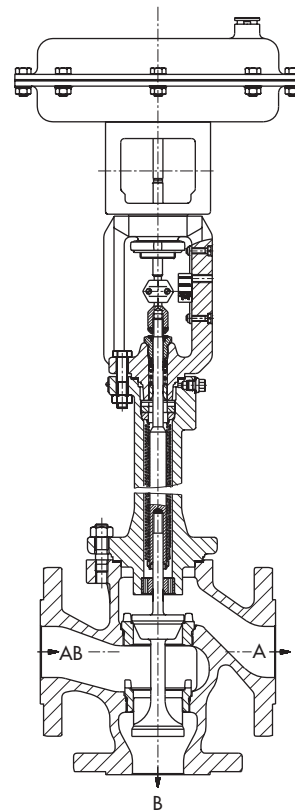

**Fig. 3:** Type 3244-1 Pneumatic Control Valve with Type 3244 Three-way Valve (plug arrangement for mixing service, DN 15 to 25 for diverting service as well, and Type 3271 Actuator with additional handwheel)



**Fig. 4:** Type 3244-7 Pneumatic Control Valve with Type 3244 Three-way Valve, DN 32 to 150 (plug arrangement for diverting service), additional bellows seal and Type 3277 Actuator

**Table 1: Technical data**

Version	DIN			ANSI	
Valve size	DN 15 to 150			NPS ½ to 6	
Material	Cast iron EN-GJL-250 (EN-JL1040)	Cast steel 1.0619	Cast stainless steel 1.4408	Cast steel A216 WCC	Cast stainless steel A351 CF8M
Pressure rating	PN 10, 16, 25, 40			Class 150 or 300	
Type of end connections	All flange types acc. to DIN EN 1092-1/-2 <sup>1)</sup>			RF <sup>2)</sup>	
Seat/plug seal	Metal seal			Metal seal	
Characteristic	Linear			Linear	
Rangeability	50:1 for DN 15 to 50 30:1 for DN 65 to 150			50:1 for NPS ½ to 2 30:1 for NPS 2½ to 6	
<b>Temperature ranges in °C and °F · Permissible operating pressures according to pressure-temperature diagrams</b>					
Body without insulating section	-10 to +220 °C			-10 to +220 °C (15 to 430 °F)	
Body with					
Short insulating section <sup>3)</sup>	-10 to +300 °C	-10 to +400 °C <sup>4)</sup>	-50 to +450 °C <sup>4)</sup>	-29 to +427 °C (-20 to +800 °F)	-50 to +450 °C (-58 to +842 °F)
Short bellows seal <sup>3)</sup>	-10 to +300 °C	-10 to +400 °C <sup>4)</sup>	-50 to +450 °C <sup>4)</sup>	-29 to +400 °C (-20 to +750 °F)	-50 to +450 °C (-58 to +842 °F)
<b>Leakage class according to IEC 60534-4 or ANSI/FCI 70-2</b>	I (0.05 % K <sub>Vs</sub> )			I (0.05 % K <sub>Vs</sub> )	
Compliance					

<sup>1)</sup> Except for tongue Form D, groove Form D and female face Form F for DN 15

<sup>2)</sup> Other versions for NPS ¾ and larger available on request

<sup>3)</sup> Long insulating section or bellows seal on request

<sup>4)</sup> Version for lower temperatures on request

**Table 2: Materials**

Standard version	DIN			ASTM	
Valve body <sup>1)</sup>	Cast iron EN-GJL-250 (EN-JL1040)	Cast steel 1.0619	Cast stainless steel 1.4408	Cast steel A216 WCC	Cast stainless steel A351 CF8M
Valve bonnet	1.0460/ EN-GJL-250 (EN-JL1040)	1.0460	1.4401/1.4404	A105	A182 F316/ A182 F316L
Seat <sup>2)</sup>	1.4006		1.4404	A182 F6a Class 2	F316L
Plug <sup>2)</sup>	1.4006		1.4404	A182 F6a Class 2	A182 F316L
Seat/plug seal	Metal seal			Metal seal	
Guide bushing	1.4104		1.4404	A 582 430F	A182 F316L
Packing <sup>3)</sup>	V-ring packing: PTFE with carbon · Spring: 1.4310/A479 302				
Body gaskets	Graphite on metal core			Graphite on metal core	
<b>Insulating section</b>	1.0460		1.4401/1.4404	A105	A182 F316/ A182 F316L
<b>Bellows seal</b>					
Intermediate piece	1.0460		1.4401/1.4404	A105	A182 F316/ A182 F316L
Metal bellows	1.4571 <sup>4)</sup>			316 Ti	

<sup>1)</sup> Special materials for applications with sea water: 1.4538, duplex 1.4470; nickel-based alloy: 9.4610; other special materials on request

<sup>2)</sup> All seats and metal-seated plug also with Stellite® facing; for ≤DN 100 plug up to seat bore 38 made of solid Stellite® available.

<sup>3)</sup> Other packings on request (see Information Sheet ▶ T 8000-1)

<sup>4)</sup> Other materials on request

**Notes on the differential pressures (Table 3.1 to Table 4.2)**

- Differential pressures in parentheses refer to the values for half travel in parentheses in the bench range column
- The tables apply to both fail-safe positions.
- The springs in actuators with fail-safe action "actuator stem retracts" cannot be preloaded.
- v2 is added to the diaphragm area (e.g. 175v2 cm<sup>2</sup>) to indicate actuators with a full diaphragm.

**Table 3:**  $K_{Vs}$  and  $C_v$  coefficients as well as permissible differential pressures for Type 3244 Mixing Valve

**Table 3.1:** DIN version · Pressures in bar

				Actuator area	Bench range	Required supply pressure	Bench range	Required supply pressure	Bench range	Required supply pressure
				120 cm <sup>2</sup>	0.4 to 2.0	2.4	1.4 to 2.3	3.7	2.1 to 3.3	4.4
				175v2 cm <sup>2</sup>	0.4 to 2.0	2.4	0.5 to 2.5	3	1.3 to 2.9	4.2
				350 cm <sup>2</sup>	0.4 to 2.0	2.4	1.4 to 2.3	3.7	2.1 to 3.3	5.4
				355v2 cm <sup>2</sup>	0.4 to 2.0 (1.2 to 2.0)	2.4 (3.2)	1.4 to 2.6 (2.0 to 2.6)	4 (4.6)	1.9 to 3.3 (2.6 to 3.3)	5.2 (5.9)
				700 cm <sup>2</sup>	0.4 to 2.0 (1.2 to 2.0)	2.4 (3.2)	1.4 to 2.3 (1.85 to 2.3)	3.7 (4.15)	2.1 to 3.3 (2.7 to 3.3)	5.4 (6)
				750v2 cm <sup>2</sup>	0.4 to 2.0 (1.2 to 2.0)	2.4 (3.2)	1.4 to 2.4 (1.9 to 2.4)	3.8 (4.3)	1.9 to 3.1 (2.5 to 3.1)	5 (5.6)
DN	$K_{Vs}$ for mixing valve	Seat Ø	Rated travel	Actuator area	$\Delta p$ when $p_2 = 0$ bar					
15	2 · 4	24	15	120 cm <sup>2</sup>	5	29	40			
20	2 · 4 · 6.3			175v2 cm <sup>2</sup>	9.5	13	40			
25	2 · 4 6.3 · 10			350 cm <sup>2</sup>	23.5	40	40			
32 to 50	6.3 · 10 16	31		120 cm <sup>2</sup>	2.5	17	27			
				175v2 cm <sup>2</sup>	5	7	24			
				350 cm <sup>2</sup>	13.5	40	40			
40 and 50	25	38		120 cm <sup>2</sup>	-	10.5	17.5			
				175v2 cm <sup>2</sup>	3.1	4.5	15.5			
				350 cm <sup>2</sup>	8.5	36.5	40			
50	40	48		120 cm <sup>2</sup>	-	6.5	10.5			
				175v2 cm <sup>2</sup>	-	2.5	9.5			
				350 cm <sup>2</sup>	5	22.5	35			
				355v2 cm <sup>2</sup>	(19.5)	(33.5)	(40)			
				700 cm <sup>2</sup>	(40)	-	-			
				750v2 cm <sup>2</sup>	(40)	-	-			
65 and 80	25 and 40	48	350 cm <sup>2</sup>	5	22.5	35				
			355v2 cm <sup>2</sup>	(19.5)	(33.5)	(40)				
			700 cm <sup>2</sup>	(40)	-	-				
	60	63	750v2 cm <sup>2</sup>	(40)	-	-				
			350 cm <sup>2</sup>	2.7	12.5	20				
			355v2 cm <sup>2</sup>	(11)	(19)	(25.5)				
			700 cm <sup>2</sup>	(23)	(36)	(40)				
80	80	75	750v2 cm <sup>2</sup>	(24.5)	(40)	(40)				
			350 cm <sup>2</sup>	-	8.5	14				
			355v2 cm <sup>2</sup>	(7.5)	(13)	(17.5)				
			700 cm <sup>2</sup>	(16)	(25.5)	(37.5)				
				750v2 cm <sup>2</sup>	(17)	(28)	(37)			

				Actuator area	Bench range	Required supply pressure	Bench range	Required supply pressure	Bench range	Required supply pressure
				120 cm <sup>2</sup>	0.4 to 2.0	2.4	1.4 to 2.3	3.7	2.1 to 3.3	4.4
				175v2 cm <sup>2</sup>	0.4 to 2.0	2.4	0.5 to 2.5	3	1.3 to 2.9	4.2
				350 cm <sup>2</sup>	0.4 to 2.0	2.4	1.4 to 2.3	3.7	2.1 to 3.3	5.4
				355v2 cm <sup>2</sup>	0.4 to 2.0 (1.2 to 2.0)	2.4 (3.2)	1.4 to 2.6 (2.0 to 2.6)	4 (4.6)	1.9 to 3.3 (2.6 to 3.3)	5.2 (5.9)
				700 cm <sup>2</sup>	0.4 to 2.0 (1.2 to 2.0)	2.4 (3.2)	1.4 to 2.3 (1.85 to 2.3)	3.7 (4.15)	2.1 to 3.3 (2.7 to 3.3)	5.4 (6)
				750v2 cm <sup>2</sup>	0.4 to 2.0 (1.2 to 2.0)	2.4 (3.2)	1.4 to 2.4 (1.9 to 2.4)	3.8 (4.3)	1.9 to 3.1 (2.5 to 3.1)	5 (5.6)
DN	K <sub>Vs</sub> for mixing valve	Seat Ø	Rated travel	Actuator area	$\Delta p$ when p <sub>2</sub> = 0 bar					
100	100	80	30	700 cm <sup>2</sup>	3.9	16.5	25			
	160	100			2.3	10	16			
125	140	90			3	13	20			
	200	110			–	8.5	13			
150	200	110			–	8.5	13			
	300	130			–	6	9			
100	100	80		750v2 cm <sup>2</sup>	4.3	17.5	24.5			
	160	100			2.6	11	15.5			
125	140	90			3.3	14	19			
	200	110			2.1	9	12.5			
150	200	110	2.1		9	12.5				
	300	130	–		6.5	9				

**Table 3.2:** ANSI version · Pressures in psi

Valve size		C <sub>v</sub> for mixing valve	Seat Ø inch (mm)	Rated travel inch (mm)	Actuator area	Δp when p <sub>2</sub> = 0 psi					
NPS	DN					Bench range	Required supply pressure	Bench range	Required supply pressure	Bench range	Required supply pressure
					120 cm <sup>2</sup>	5 to 29	34	20 to 33	53	30 to 47	63
					175v2 cm <sup>2</sup>	5 to 29	34	7 to 36	43	18 to 42	60
					350 cm <sup>2</sup>	5 to 29	34	20 to 33	53	30 to 47	78
					355v2 cm <sup>2</sup>	5 to 29 (17 to 29)	34 (46)	20 to 37 (29 to 37)	58 (66)	27 to 47 (37 to 47)	75 (85)
					700 cm <sup>2</sup>	5 to 29 (17 to 29)	34 (46)	20 to 33 (26 to 33)	53 (60)	30 to 47 (39 to 47)	78 (87)
					750v2 cm <sup>2</sup>	5 to 29 (17 to 29)	34 (46)	20 to 34 (27 to 34)	55 (62)	27 to 44 (36 to 44)	72 (81)
Valve size		C <sub>v</sub> for mixing valve	Seat Ø inch (mm)	Rated travel inch (mm)	Actuator area	Δp when p <sub>2</sub> = 0 psi					
NPS	DN					Bench range	Required supply pressure	Bench range	Required supply pressure	Bench range	Required supply pressure
½	15	2.3 · 5	0.94 (24)	0.59 (15)	120 cm <sup>2</sup>			420		580	
¾	20	2.3 · 5 7.5			175v2 cm <sup>2</sup>	72		137	188		580
1	25	2.3 · 5 7.5 · 12			350 cm <sup>2</sup>	340		580		580	
1½ and 2	40 and 50	7.5 · 12 20	1.22 (31)		120 cm <sup>2</sup>	36		246		391	
					175v2 cm <sup>2</sup>	72		101		348	
					350 cm <sup>2</sup>	195		580		580	
2	50	47	1.49 (38)		120 cm <sup>2</sup>	–		152		253	
					175v2 cm <sup>2</sup>	44		65		224	
					350 cm <sup>2</sup>	123		529		580	
2½ and 3	65 and 80	30 and 47	1.89 (48)		120 cm <sup>2</sup>	–		94		152	
					175v2 cm <sup>2</sup>	–		36		137	
					350 cm <sup>2</sup>	72		326		507	
3	80	95	2.48 (63)		355v2 cm <sup>2</sup>	(282)		(485)		(580)	
					700 cm <sup>2</sup>	(580)		–		–	
					750v2 cm <sup>2</sup>	(580)		–		–	
3	80	95	2.95 (75)		350 cm <sup>2</sup>	72		326		507	
					355v2 cm <sup>2</sup>	(282)		(485)		(580)	
					700 cm <sup>2</sup>	(580)		–		–	
3	80	95	2.48 (63)		750v2 cm <sup>2</sup>	(580)		–		–	
					350 cm <sup>2</sup>	39		181		290	
					355v2 cm <sup>2</sup>	(159)		(275)		(369)	
3	80	95	2.95 (75)		700 cm <sup>2</sup>	(333)		(522)		(580)	
					750v2 cm <sup>2</sup>	(355)		(580)		(580)	
					350 cm <sup>2</sup>	–		123		203	
3	80	95	2.95 (75)		355v2 cm <sup>2</sup>	(108)		(188)		(253)	
					700 cm <sup>2</sup>	(232)		(369)		(543)	
					750v2 cm <sup>2</sup>	(246)		(406)		(536)	

					Actuator area	Bench range	Required supply pressure	Bench range	Required supply pressure	Bench range	Required supply pressure
					120 cm <sup>2</sup>	5 to 29	34	20 to 33	53	30 to 47	63
					175v2 cm <sup>2</sup>	5 to 29	34	7 to 36	43	18 to 42	60
					350 cm <sup>2</sup>	5 to 29	34	20 to 33	53	30 to 47	78
					355v2 cm <sup>2</sup>	5 to 29 (17 to 29)	34 (46)	20 to 37 (29 to 37)	58 (66)	27 to 47 (37 to 47)	75 (85)
					700 cm <sup>2</sup>	5 to 29 (17 to 29)	34 (46)	20 to 33 (26 to 33)	53 (60)	30 to 47 (39 to 47)	78 (87)
					750v2 cm <sup>2</sup>	5 to 29 (17 to 29)	34 (46)	20 to 34 (27 to 34)	55 (62)	27 to 44 (36 to 44)	72 (81)
Valve size		C <sub>v</sub> for mixing valve	Seat Ø inch (mm)	Rated travel inch (mm)	Actuator area	Δp when p <sub>2</sub> = 0 psi					
NPS	DN										
4	100	120	3.15 (80)	1.18 (30)	700 cm <sup>2</sup>	56	239	362			
		190	3.93 (100)			33	145	232			
6	150	230	4.33 (110)			–	123	188			
		350	5.12 (130)			–	87	130			
4	100	120	3.15 (80)		750v2 cm <sup>2</sup>	62	253	355			
		190	3.93 (100)			37	159	224			
6	150	230	4.33 (110)			30	130	181			
		350	5.12 (130)			–	94	130			

**Table 4:**  $K_{VS}$  and  $C_V$  coefficients as well as permissible differential pressures for Type 3244 Diverting Valve

**Table 4.1:** DIN version · Pressures in bar

**Valves in DN 65 to 150**

- Direction of flow AB  $\Rightarrow$  A with maximum  $K_{VS}$
- Direction of flow AB  $\Rightarrow$  B with reduced  $K_{VS}$

				Actuator area	Bench range	Required supply pressure	Bench range	Required supply pressure	Bench range	Required supply pressure
				120 cm <sup>2</sup>	0.4 to 2.0	2.4	1.4 to 2.3	3.7	2.1 to 3.3	4.4
				175v2 cm <sup>2</sup>	0.4 to 2.0	2.4	0.5 to 2.5	3	1.3 to 2.9	4.2
				350 cm <sup>2</sup>	0.4 to 2.0	2.4	1.4 to 2.3	3.7	2.1 to 3.3	5.4
				355v2 cm <sup>2</sup>	0.4 to 2.0 (1.2 to 2.0)	2.4	1.4 to 2.6 (2.0 to 2.6)	4 (4.6)	1.9 to 3.3 (2.6 to 3.3)	5.2 (5.9)
				700 cm <sup>2</sup>	0.4 to 2.0 (1.2 to 2.0)	2.4 (3.2)	1.4 to 2.3 (1.85 to 2.3)	3.7 (4.15)	2.1 to 3.3 (2.7 to 3.3)	5.4 (6)
				750v2 cm <sup>2</sup>	0.4 to 2.0 (1.2 to 2.0)	2.4	1.4 to 2.4 (1.9 to 2.4)	3.8 (4.3)	1.9 to 3.1 (2.5 to 3.1)	5 (5.6)
DN	$K_{VS}$ for diverting valve	Seat $\varnothing$	Rated travel	Actuator area	$\Delta p$ when $p_2 = 0$ bar					
15	2 · 4	24	15	120	5	29	40			
20	2 · 4 · 6.3			175v2	9.5	13	40			
25	2 · 4 6.3 · 10			350	23.5	40	40			
32 to 50	6.3 · 10 16	31		120	2.5	17	27			
				175v2	5	7	24			
				350	13.5	40	40			
40 and 50	25	38		120	-	10.5	17.5			
				175v2	3.1	4.5	15.5			
				350	8.5	36.5	40			
50 to 80	40	48		120	-	6.5	10.5			
				175v2	-	2.5	9.5			
				350	5	22.5	35			
				355v2	(19.5)	(33.5)	(40)			
				700	(40)	-	-			
65 and 80	25 and 40	48		750v2	(40)	-	-			
			350	5	22.5	35				
			355v2	(19.5)	(33.5)	(40)				
			700	(40)	-	-				
65	60/40	63/48	750v2	(40)	-	-				
			350	2.7	12.5	20				
			355v2	(11)	(19)	(25.5)				
			700	(23)	(36)	(40)				
80	60	63	750v2	(24.5)	(40)	(40)				
			350	2.7	12.5	20				
			355v2	(11)	(19)	(25.5)				
			700	(23)	(36)	(40)				
80	80/60	75/63	750v2	(24.5)	(40)	(40)				
			350	-	8.5	14				
			355v2	(7.5)	(13)	(17.5)				
			700	(16)	(25.5)	(37.5)				
				750v2	(17)	(28)	(37)			



				Actuator area	Bench range	Required supply pressure	Bench range	Required supply pressure	Bench range	Required supply pressure
				120 cm <sup>2</sup>	0.4 to 2.0	2.4	1.4 to 2.3	3.7	2.1 to 3.3	4.4
				175v2 cm <sup>2</sup>	0.4 to 2.0	2.4	0.5 to 2.5	3	1.3 to 2.9	4.2
				350 cm <sup>2</sup>	0.4 to 2.0	2.4	1.4 to 2.3	3.7	2.1 to 3.3	5.4
				355v2 cm <sup>2</sup>	0.4 to 2.0 (1.2 to 2.0)	2.4	1.4 to 2.6 (2.0 to 2.6)	4 (4.6)	1.9 to 3.3 (2.6 to 3.3)	5.2 (5.9)
				700 cm <sup>2</sup>	0.4 to 2.0 (1.2 to 2.0)	2.4 (3.2)	1.4 to 2.3 (1.85 to 2.3)	3.7 (4.15)	2.1 to 3.3 (2.7 to 3.3)	5.4 (6)
				750v2 cm <sup>2</sup>	0.4 to 2.0 (1.2 to 2.0)	2.4	1.4 to 2.4 (1.9 to 2.4)	3.8 (4.3)	1.9 to 3.1 (2.5 to 3.1)	5 (5.6)
DN	K <sub>Vs</sub> for diverting valve	Seat Ø	Rated travel	Actuator area	$\Delta p$ when p <sub>2</sub> = 0 bar					
100	100	80	30	700	3.9	16.5	25			
	160/100	100/80			2.3	10	16			
125	140	90			3	13	20			
	200/140	110/90			–	8.5	13			
150	200	110			–	8.5	13			
	300/200	130/110			–	6	9			
100	100	80		750v2	4.3	17.5	24.5			
	160/100	100/80			2.6	11	15.5			
125	140	90			3.3	14	19			
	200/140	110/90			2.1	9	12.5			
150	200	110	2.1		9	12.5				
	300/200	130/110	–		6.5	9				

**Table 4.2:** ANSI version · Pressures in psi

**Valves in NPS 2½ to 6**

- Direction of flow AB ⇒ A with maximum C<sub>v</sub>
- Direction of flow AB ⇒ B with reduced C<sub>v</sub>

					Actuator area	Bench range	Required supply pressure	Bench range	Required supply pressure	Bench range	Required supply pressure
					120 cm <sup>2</sup>	5 to 29	34	20 to 33	53	30 to 47	63
					175v2 cm <sup>2</sup>	5 to 29	34	7 to 36	43	18 to 42	60
					350 cm <sup>2</sup>	5 to 29	34	20 to 33	53	30 to 47	78
					355v2 cm <sup>2</sup>	5 to 29 (17 to 29)	34 (46)	20 to 37 (29 to 37)	58 (66)	27 to 47 (37 to 47)	75 (85)
					700 cm <sup>2</sup>	5 to 29 (17 to 29)	34 (46)	20 to 33 (26 to 33)	53 (60)	30 to 47 (39 to 47)	78 (87)
					750v2 cm <sup>2</sup>	5 to 29 (17 to 29)	34 (46)	20 to 34 (27 to 34)	55 (62)	27 to 44 (36 to 44)	72 (81)
Valve size		C <sub>v</sub> for diverting valve	Seat Ø inch (mm)	Rated travel inch (mm)	Actuator area	Δp when p <sub>2</sub> = 0 psi					
NPS	DN										
½	15	2.3 · 5	0.94 (24)	0.59 (15)	120 cm <sup>2</sup>	72	420	580			
¾	20	2.3 · 5 7.5			175v2 cm <sup>2</sup>	137	188	580			
1	25	2.3 · 5 7.5 · 12			350 cm <sup>2</sup>	340	580	580			
1½ and 2	40 and 50	7.5 · 12 20	1.22 (31)		120 cm <sup>2</sup>	36	246	391			
					175v2 cm <sup>2</sup>	72	101	348			
					350 cm <sup>2</sup>	195	580	580			
		30	1.49 (38)		120 cm <sup>2</sup>	-	152	253			
					175v2 cm <sup>2</sup>	44	65	224			
					350 cm <sup>2</sup>	123	529	580			
2	50	47	1.89 (48)		120 cm <sup>2</sup>	-	94	152			
					175v2 cm <sup>2</sup>	-	36	137			
					350 cm <sup>2</sup>	72	326	507			
					355v2 cm <sup>2</sup>	(282)	(485)	(580)			
					700 cm <sup>2</sup>	(580)	-	-			
					750v2 cm <sup>2</sup>	(580)	-	-			
2½ and 3	65 and 80	30 and 47	1.89 (48)		350 cm <sup>2</sup>	72	326	507			
					355v2 cm <sup>2</sup>	(282)	(485)	(580)			
					700 cm <sup>2</sup>	(580)	-	-			
		70	2.48 (63)		750v2 cm <sup>2</sup>	(580)	-	-			
					350 cm <sup>2</sup>	39	181	290			
					355v2 cm <sup>2</sup>	(159)	(275)	(369)			
					700 cm <sup>2</sup>	(333)	(522)	(580)			
					750v2 cm <sup>2</sup>	(355)	(580)	(580)			
					350 cm <sup>2</sup>	-	123	203			
3	80	95/70	2.95/2.48 (75/63)		355v2 cm <sup>2</sup>	(108)	(188)	(253)			
					700 cm <sup>2</sup>	(232)	(369)	(543)			
					750v2 cm <sup>2</sup>	(246)	(406)	(536)			

				Actuator area	Bench range	Required supply pressure	Bench range	Required supply pressure	Bench range	Required supply pressure
				120 cm <sup>2</sup>	5 to 29	34	20 to 33	53	30 to 47	63
				175v2 cm <sup>2</sup>	5 to 29	34	7 to 36	43	18 to 42	60
				350 cm <sup>2</sup>	5 to 29	34	20 to 33	53	30 to 47	78
				355v2 cm <sup>2</sup>	5 to 29 (17 to 29)	34 (46)	20 to 37 (29 to 37)	58 (66)	27 to 47 (37 to 47)	75 (85)
				700 cm <sup>2</sup>	5 to 29 (17 to 29)	34 (46)	20 to 33 (26 to 33)	53 (60)	30 to 47 (39 to 47)	78 (87)
				750v2 cm <sup>2</sup>	5 to 29 (17 to 29)	34 (46)	20 to 34 (27 to 34)	55 (62)	27 to 44 (36 to 44)	72 (81)
Valve size		C <sub>v</sub> for diverting valve	Seat Ø inch (mm)	Rated travel inch (mm)	Actuator area	Δp when p <sub>2</sub> = 0 psi				
NPS	DN									
4	100	120	3.15 (80)	1.18 (30)	700 cm <sup>2</sup>	56	239	362		
		190/120	3.93/3.15 (100/80)			33	145	232		
6	150	230	4.33 (110)			-	123	188		
		350/230	5.12/4.33 (130/110)			-	87	130		
4	100	120	3.15 (80)		750v2 cm <sup>2</sup>	62	253	355		
		190/120	3.93/3.15 (100/80)			37	159	224		
6	150	230	4.33 (110)			30	130	181		
		350/230	5.12/4.33 (130/110)			-	94	130		

**Table 5: Dimensions**

**Table 5.1: Type 3244 Valve · DIN version**

Valve	DN	15	20	25	32	40	50	65	80	100	125	150
Length L	mm	130	150	160	180	200	230	290	310	350	400	480
H1	mm	235						270		360	375	
H2	mm	70	80	85	100	105	120	130	140	150	200	210

**Table 5.2: Type 3244 Valve · ANSI version**

Valve	NPS	DN	½	¾	1	1½	2	2½	3	4	6
			15	20	25	40	50	65	80	100	150
Length L	Class 150	mm	184	184	184	222	254	276	298	352	451
		in	7.25	7.25	7.25	8.75	10.0	10.88	11.75	13.88	17.75
	Class 300	mm	190	194	197	235	267	292	318	368	473
		in	7.50	7.62	7.75	9.25	10.50	11.50	12.50	14.50	18.62
H1	mm	235						270		360	375
	in	9.25						10.63		14.17	14.76
H2	Class 150	mm	92	92	92	111	127	138	149	176	225.5
		in	3.62	3.62	3.62	4.37	5.0	5.43	5.87	6.93	8.88
	Class 300	mm	95	97	98.5	117.5	133.5	146	159	184	236.5
		in	3.76	3.82	3.88	4.63	5.26	5.75	6.26	7.24	9.31

**Table 5.3: Type 3271 and Type 3277 Actuators**

Actuator area	cm²	120	175v2	350	355v2	700	750v2
Diaphragm ØD	in	6.61	8.46	11.02	11.02	15.35	15.51
	mm	168	215	280	280	390	394
H <sup>1)</sup>	in	2.71	3.07	3.23	4.76	7.83	9.29
	mm	69	78	82	121	199	236
H3 <sup>2)</sup>	in	4.33	4.33	4.33	4.33	7.48	7.48
	mm	110	110	110	110	190	190
H5	Type 3277 in	3.46	3.98	3.98	3.98	3.98	3.98
	Type 3277 mm	88	101	101	101	101	101
Thread	Type 3271	M30 x 1.5					
	Type 3277	M30 x 1.5					
α	Type 3271	G ⅛ (⅛ NPT)	G ¼ (¼ NPT)	G ⅜ (⅜ NPT)	G ⅜ (⅜ NPT)	G ⅜ (⅜ NPT)	G ⅜ (⅜ NPT)
α2	Type 3277	–	G ⅜	G ⅜	G ⅜	G ⅜	G ⅜

<sup>1)</sup> Height with welded-on lifting eyelet or height of eyebolt according to DIN 580. Height of the swivel lifting hook may differ. Actuators up to 355v2 cm² without lifting eyelet

<sup>2)</sup> Minimum clearance required to remove the actuator

**Table 5.4: Version with insulating section or bellows seal /long insulating section or bellows seal**

Valve	DN	NPS	15	20	25	32	40	50	65	80	100	125	150
			½	¾	1	–	1½	2	2½	3	4	–	6
H4	With insulating section or bellows seal	mm	420						455	645	655		
		in	16.54						17.91	25.39	25.79		
	With long insulating section or bellows seal	mm	725						760	895	900		
		in	28.54						29.92	35.24	35.43		

**Table 6:** Weights

**Table 6.1:** Type 3244 Valve

Valve		DN	15	20	25	32	40	50	65	80	100	125	150
		NPS	½	¾	1	–	1½	2	2½	3	4	–	6
Valve without actuator		kg	6	7	8	13	15	17	31	37	49	95	135
		lbs	13	15.5	17.5	28.7	33	37.5	68	82	108	210	298
Weight with	Insulating section or bellows seal	kg	9	10	11	19	21	23	40	45	68	120	165
		lbs	20	22	24	42	46.3	50.7	88	99	150	265	364
	Long insulating section or bellows seal	kg	13	14	15	23	25	27	44	49	76	128	173
		lbs	28.7	30.9	33	50.7	55	59.5	97	108	168	282	382

**Table 6.2:** Type 3271 and Type 3277 Actuators

Actuator		cm <sup>2</sup>	120	175v2	350	355v2	700	750v2
		in <sup>2</sup>	18.6	27.13	54.2	55.03	108.5	116.25
Weight for Type 3271 without/with handwheel	Without	kg	2.5	6	8	15	22	36
		lbs	4.4	13.2	18	33.1	48.5	79.4
	With	kg	–	10	13	20	27	41
		lbs	–	22	29	44.1	59.5	90.4
Weight for Type 3277 without/with handwheel	Without	kg	3.2	10	12	19	26	40
		lbs	7.1	22	26.5	41.9	57.5	88.2
	With	kg	–	14	17	24	31	45
		lbs	–	30.9	37.5	52.9	68	99.2

**Dimensional drawings**

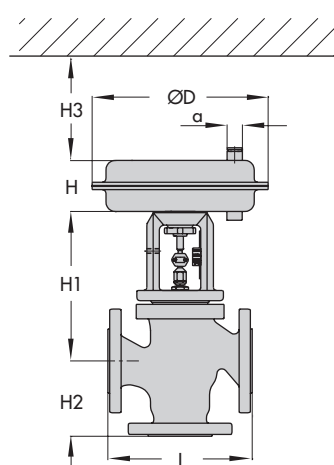

Type 3244 Valve with Type 3271 Actuator

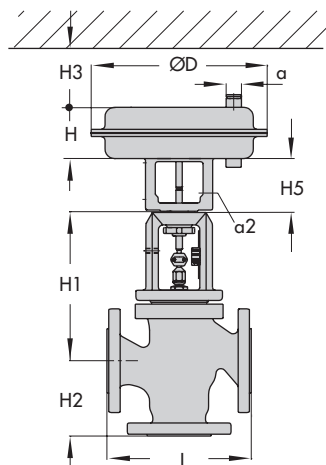

Type 3244 Valve with Type 3277 Actuator

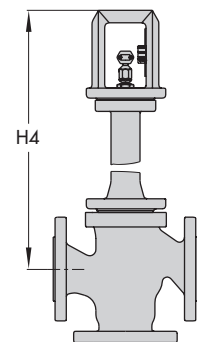

Type 3244 Valve with insulating section or bellows seal

## Ordering text

Mixing or diverting valve	
Valve size	DN .../NPS ...
Nominal pressure	PN .../Class ...
Body material	According to Table 2
Actuator	Type 3271 or Type 3277
Fail-safe position	Actuator stem extends or retracts
Process medium	
Density	in kg/m <sup>3</sup> or lb/ft <sup>3</sup>
Temperature	in °C or °F
Flow rate	kg/h or cu. ft/min in standard or operating state
Upstream pressure	p <sub>1</sub> in bar or psi (absolute pressure p <sub>abs</sub> )
Downstream pressure	p <sub>2</sub> in bar or psi (absolute pressure p <sub>abs</sub> ) with minimum, normal and maximum flow rate
Valve accessories	Positioner and/or limit switch



Note: The temperature limits for DIN and ANSI versions are not directly converted temperatures.