

DAF Genleşme Tankları

değiştirilebilir membranlı genleşme tankları

T-TM-TR-TH



MAS **DAF**
Mas Grup



teknik bilgiler

SELECTION OF EXPANSION VESSEL SIZE

According to ANCC technical specifications, selection of vessel size to be installed is derived as follows:
This vessel sizing formula is general use. In the UK, BS 7074 covers the application, selection and installation of expansion vessels and gives similar results.

$$V_o = \frac{e \times c}{1 - P_f/P_i}$$

(tolerance = + 10%)

Where

Vu = Total useful volume of tank = Vi - Vf

Vi = Initial volume

Vf = Final volume

e = Expansion coefficient corresponding to the difference between the cold system water temperature (heating off) and the boiling point of water at atmospheric pressure. In standard systems, e = approx 0.35 (90°C, i.e. 100 - 10).

c = Total water capacity of the systems in litres: boiler, pipework, radiators etc (as a general approximation, C is between 10 and 20 liters for every kW of boiler output).

Pi = Initial charge pressure (absolute) of vessel. This pressure must not be less than the hydrostatic pressure at the point where the tank is connected to the system

Pf = Maximum operating pressure (absolute) of the pressure relief (safety) valve, taking into account any differences in level between the vessel and safety valve.

SELECTION OF PRESSURE

In order to avoid an excessive number of starting-ups of the pumps practical experience indicates that the reserve of water contained in a tank must be equal to at least a quarter of the plant's

$$\text{maximum absorption capacity: } V_u = \frac{A \max}{4}$$

This ratio, which we retain valid for plants having electropumps of up to 2 HP, should be multiplied by:

1.5 for installations with pumps from 2.5 to 4 HP

2.5 for installations with pumps from 5 to 8 HP

3.5 for installations with pumps from 9 to 12 HP

The following data

- min. pressure thrustmeter

Pi (eg Pi = 1.5 ate)

- max. pressure thrustmeter

Pf (eg Pf = 3.5 ate)

- maximum absorption

A max (eg A max = 115 lt)

- Electropump power (eg = 4 HP)

for the tank (Vt), which is to be installed, we shall apply the formula:

$$V_t = \frac{A \max \times 1.5}{4} \times \frac{P_f + 1}{P_f - P_i}$$

$$\text{es. } V_t = \frac{115 \times 1.5}{4} \times \frac{3.5 + 1}{3.5 - 1.5} = 97 \text{ liters}$$

GENLEŞME DEPOSU SEÇİMİ

ANCC Teknik şartlarında göre monte edilecek genleşme deposu seçimi aşağıdaki formülle hesap edilebilir.

$$V_o = \frac{e \times c}{1 - P_f/P_i} \text{ Litre}$$

(Tolerans %10)

Bu formülde sırasıyla;

Vu = Vi - Vf = Toplam faydalı hacim

Vi = İlk hacim (Deponun fabrika çıkışında içerisindeki N₂ hacmi)

Vf = Son hacim (Sistemde bağlı iken N₂ hacmi)

e = Suyun genleşme katsayısı (90 / 70 sisteminde e=0.35)

C = Sistemdeki toplam su hacmi - kazan, borular, radyatör, vs. - (Genel bir yaklaşımla C katsayısı her bir kazan kapasitesi - kW - için 10-20 Litre arasında alınır.

Pi = İlk doldurma basıncı (mutlak basınç) - bu basınç sistemdeki statik basınçtan küçük olamaz-

Pf = Maksimum çalışma basıncı (emniyet ventili ayar basıncı) - mutlak basınç

GARANTİ:

DAF kapalı genleşme depoları, üretim tarihinden (fatura tarihinden) itibaren iki yıl FABRİKA GARANTİSİ altındadır. Uzman kişilerce monte edilmeyen veya depo üzerinde belirtilen basınç ve sıcaklığın üzerinde çalıştırılan cihazlar, bu garanti kapsamı dışındadır. Garanti süresi içerisinde herhangi bir nedenle tesisattan sökülmüş veya onarım nedeni ile müdahale edilmiş genleşme depoları için garanti süresinde uzatma yapılmaz.

Toptan satışlarda yükleme işlemi İstanbul'daki depomuzdan ücretsiz olarak yapılır. İstanbul dışındaki sevkiyatlarda, teslim yeri müşterinin İstanbul'daki ambarıdır. Firmamız önceden herhangi bir duyuruya gerek duymaksızın ürünleri üzerinde her türlü değişiklik yapma hakkına sahiptir. Arızalı depolar, İstanbul merkez depomuzda teslim edilmelidir.

Not: Prospektüsdeki tüm ölçüleri ve kapasiteleri değiştirme hakkımız saklıdır.

BASINÇ TANKI SEÇİMİ

Pompanın aşırı sayıda devreye girip çıkmasını önlemek için pratik bir yaklaşımla genleşme deposu içerisindeki rezerve su miktarı, en az sistemin maksimum su kapasitesinin 1/4'ü kadar olmalıdır.

$$V_u = \frac{A \max}{4} \quad V_u = \text{Genleşme deposundaki su miktarı}$$
$$A \max = \text{Sistemdeki maks. su kapasitesi}$$

Yukarıdaki oran 2.5 HP gücü kadar olan pompalar için geçerlidir. Bunun üzerindeki kapasiteler Vu aşağıdaki değerlerle çarpılmalıdır.

2.5 - 4 HP güçleri arasında çarpan = 1.5

5 - 8 HP güçleri arasında çarpan = 2.5

9 - 12 HP güçleri arasında çarpan = 3.5

Örnek olarak: ön basınç (Pi) - 1.5 bar / max. çalışma basıncı (Pf) = 3.5 bar / Amax = 115 lt / Pompa gücü = 4 HP

$$V_t = \frac{A \max \times 1.5}{4} \times \frac{P_f + 1}{P_f - P_i}$$

$$\text{es. } V_t = \frac{115 \times 1.5}{4} \times \frac{3.5 + 1}{3.5 - 1.5} = 97 \text{ litre}$$



Mas Grup











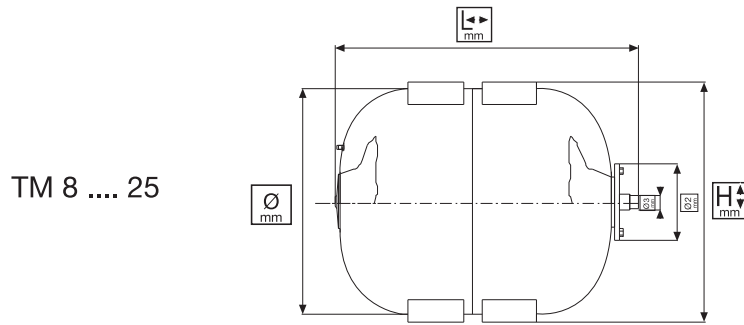

TH Serisi





YATAY TİP DENGELİ TANKLARI

HORIZONTAL PRESSURE TANKS







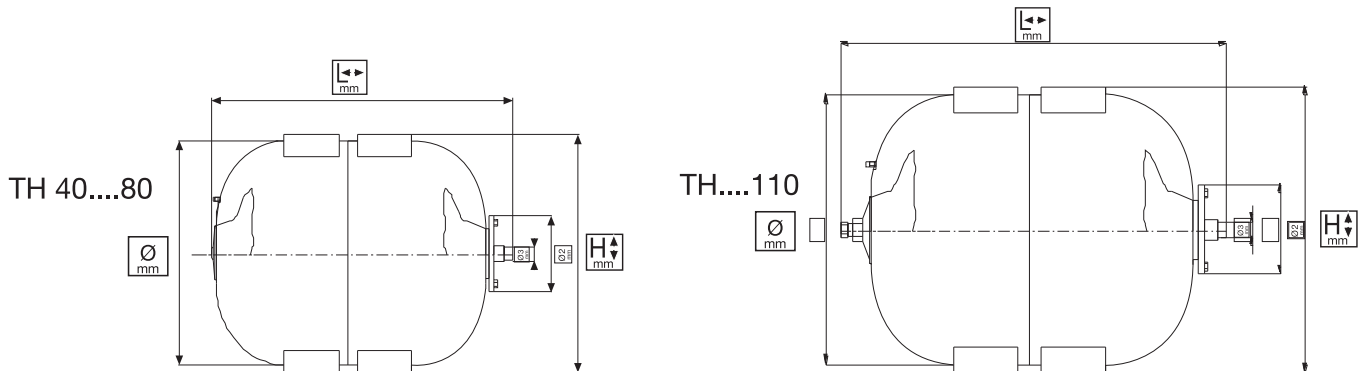

 18...24 lt
  P MAX 6 - 8 bar
  P PRE 2 bar
  EPDM
  max. + 99°C



CODE	MOD										
M101950009	TH 8	8	220	240	320	97	3/4	0,019	331	231	255
M101950013	TH 12	12	260	280	330	150	1	0,027	342	272	295
M101950017	TH 16	16	260	280	355	150	1	0,029	367	272	295
M101950022	TH 20	20	260	285	430	150	1	0,036	442	272	300
M101950027	TH 25	25	260	280	500	150	1	0,041	512	272	295

 40...110 lt
  P MAX 8 - 10 bar
  P PRE 2 bar
  EPDM
  max. + 99°C



CODE	MOD										
M101950045	TH 40	40	365	385	520	150	1	0,080	532	377	400
M101950055	TH 50	50	365	385	575	150	1	0,088	587	377	400
M101950065	TH 60	60	365	385	635	150	1	0,097	647	377	400
M101950085	TH 80	80	460	480	780	150	1	0,185	792	472	495
M101950115	TH 110	110	460	480	840	150	1	0,199	852	472	495

T/TM Serisi

GENLEŞME TANKLARI

VERTICAL PRESSURE TANKS



8 ... 50 lt



6 - 8 bar



1,5 bar



EPDM



max. + 99°C

T 8 ... 50

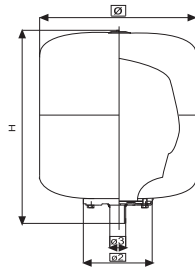

TB ... 25

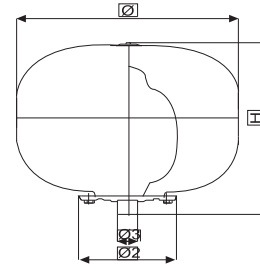

CODE	MOD	lt	Ø mm	H mm	mm	Ø2 mm	Ø3 mm	m³	mm
M1009500008	T 8	8	220	320		97	3/4"	0,017	231 231 332
M1009500012	T 12	12	260	330		150	1"	0,025	271 271 345
M1009500016	T 16	16	260	355		150	1"	0,027	272 272 370
M1009500020	T 20	20	260	430		150	1"	0,032	272 272 445
M1009500025	T 25	25	260	500		150	1"	0,038	272 272 515
M1009500029	TB 25	25	360	370		150	1"	0,053	372 372 385
M1009500040	T 40	40	365	520		150	1"	0,076	535 377 377
M1009500050	T 50	50	365	575		150	1"	0,083	590 377 377



60...1000 lt



8 - 10 bar



2 bar



EPDM



max. + 99°C

TM 60 ... 80

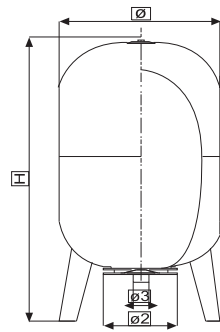

TM 110 ... 1000

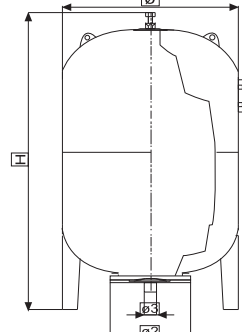

CODE	MOD	lt	Ø mm	H mm	mm	Ø2 mm	Ø3 mm	m³	mm
M100950067	TM 60	60	365	730		150	1"	0,121	742 417 392
M100960080	TM 80	80	460	890		150	1"	0,202	902 472 475
M100960110	TM 110	110	460	950		150	1"	0,215	962 472 475
M100960200	TM 200	200	585	1215		270	1 1/2"	0,439	1227 597 600
M100960300	TM 300	300	640	1390		270	1 1/2"	0,597	1402 651 655
M100960500	TM 500	500	750	1550		270	1 1/2"	0,910	1562 762 765
M100960750	TM 750	750	800	1965		300	2"	pallet	
M1009601000	TM 1000	1000	800	2465		300	2"	pallet	



Mas Grup



TM Serisi

GENLEŞME TANKLARI

VERTICAL PRESSURE TANKS



1500...5000 lt



8 - 10 bar



2 bar



EPDM



max. + 99°C

TM
1500....2500

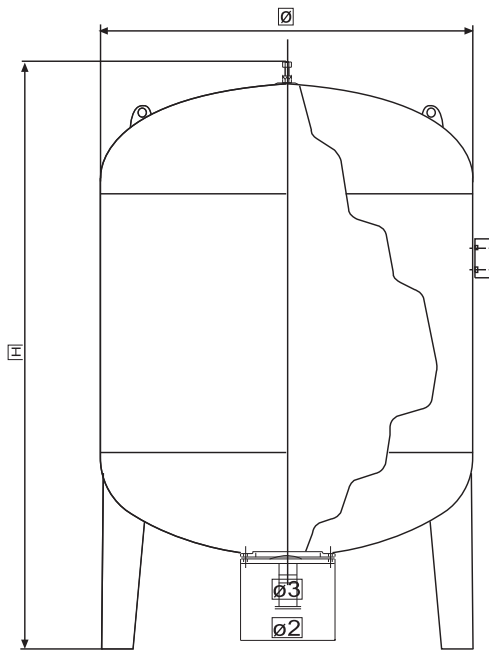

TM
3000....5000

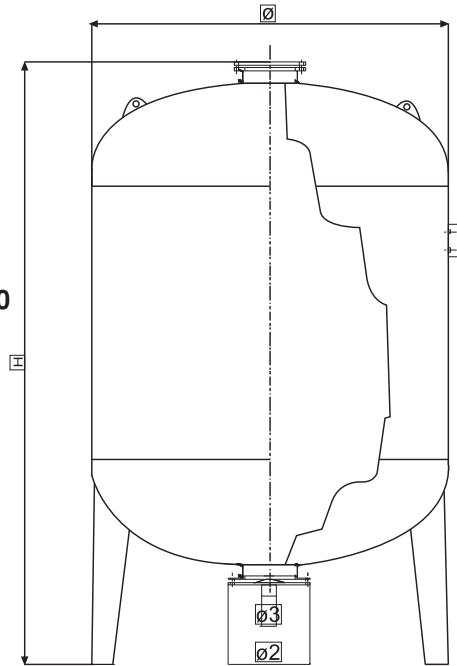

CODE	MOD	lt	mm	H mm	mm	Ø2 mm	Ø3 mm	m ³	mm
M100960850	TM 1500	1500	1200	1990		300	2"	pallet	
M100960900	TM 2000	2000	1200	2450		270	2 1/2"	pallet	
M100960925	TM 2500	2500	1200	2865		350	3"	pallet	
M100960955	TM 3000	3000	1500	2590		350	3"	pallet	
M100960960	TM 4000	4000	1500	2955		350	3"	pallet	
M100960970	TM 5000	5000	1500	3550		350	3"	pallet	

TR Serisi

GENLEŞME TANKLARI

VERTICAL PRESSURE TANKS



110....1000 lt



15 bar



5 bar



EPDM



max. + 70°C

TR 110 1000

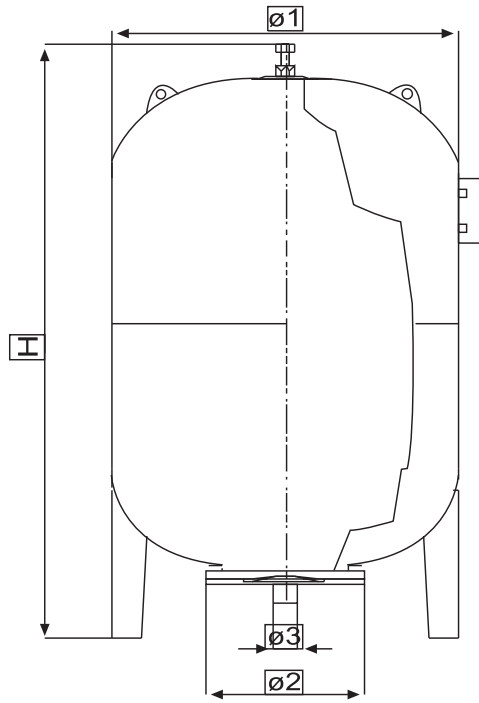

CODE	MOD	lt	mm	H mm	mm	Ø2 mm	Ø3 mm	m ³	mm	mm	mm
M100970110	TR 110	110	450	1030		150	1"	0,215	1045	462	465
M100970200	TR 200	200	640	1165		270	1 1/2"	0,439	1180	652	655
M100970300	TR 300	300	640	1390		270	1 1/2"	0,597	1402	651	655
M100970500	TR 500	500	750	1550		270	1 1/2"	0,910	1562	762	765
M100970750	TR 750	750	800	1965		300	2"	pallet			
M1009701000	TR 1000	1000	800	2465		300	2"	pallet			

Yedek Parçalar

Spare Parts



Hava Ventili - Air valve

AUTOCLAVE PRESSURE TANK CODE	
A123500030	8 ... 110
A123500010	200...5000

Manometre - Pressure gauge

	CODE	BAR	
	A177802010	10÷16	50
	A177802020	10÷16	63

Karşı flanş - Counterflange

	CODE	
	Y090310010	8 LT
	Y090310020	12...110LT

Membran - Bladder

	CODE	
	A112700010	8
	A112700030	12-16-20-24
	A112700040	40-50
	A112700090	60-80
	A112700050	100
	A112700060	200-300
	A112700070	500-750
	A112700080	1000

Karşı flanş - Counterflange

	CODE	
	Y090310030	200...500 LT
	Y090310040	750...1500 LT
	Y090310050	2000...3000 LT
	Y090310050	4000...5000 LT

