

Y TİPİ PİSLİK TUTUCU (PN 25) -Y TYPE STRAINER (PN 25)

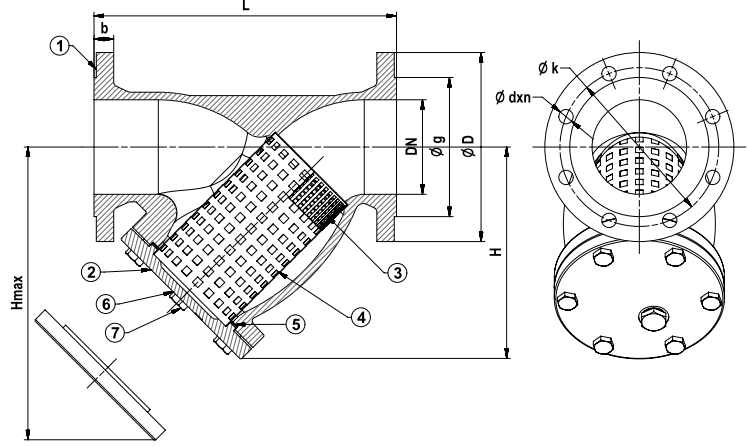

T-0865 Sfero Döküm / Ductile Iron



Genel Özellikler / General Specifications

Çalışma Sıcaklık Aralığı / Working Temperature : -10 ... +120 °C (25 Bar),
200 °C (23 Bar), 250 °C (21,8 Bar), 300 °C (20 Bar), 350 °C (17,5 Bar)

Standartlar / Standards

Sertifikalar / Certificates :

Tasarım / Design : TS 11494

Flanş Boyutları / Flange Dimensions : TS EN 1092-2 (PN 25)

Alından Alına Boyutlar / Face to Face Dimensions : TS EN 558 (Seri 1)

Testler / Tests : TS EN 12266-1

Uygulamalar / Applications

Sıcak ve soğuk su sistemleri, basınçlı hava, doymuş buhar, asit ve alkali özelliği bulunmayan sıvı akışkanlar
Hot and cold water systems, compressed air, saturated steam, non-acidic and non-flammable liquid fluids

Malzeme Özellikleri / Material Specifications	No	Parça Adı / Part Name	Malzeme / Material
	1	Gövde / Body	GGG 40 - EN GJS 400-15 - Sfero Döküm / Ductile Iron
	2	Kapak / Bonet	GGG 40 - EN GJS 400-15 - Sfero Döküm / Ductile Iron
	3	Filtre / Filter	X5CrNi18 10 - AISI304 - Paslanmaz Çelik / Stainless Steel
	4	Takviye Sacı / Reinforcing Frame (DN 50-200)	Paslanmaz Çelik / Stainless Steel
	5	Conta / Gasket	Klingerit
	6	Tapa Contası / Plug Gasket (DN 50-200)	Bakır / Copper
	8	Tapa / Plug (DN 50-200)	St37

Ölçüler / Dimensions	Anma Basıncı / Nominal Pressure	25 Bar												
	Anma Çapı / Nominal Diameter	DN	15	20	25	32	40	50	65	80	100	125	150	200
	Vana Boyutları / Valve Dimensions	L	130	150	160	180	200	230	290	310	350	400	480	600
		H	65	78	88	126	135	145	165	175	236	267	298	340
		H max.	117	140	160	203	232	260	333	363	454	510	579	657
		D	95	105	115	140	150	165	185	200	235	270	300	360
		k	65	75	85	100	110	125	145	160	190	220	250	310
		g	46	56	65	76	84	99	118	132	156	184	211	274
		b	14	16	18	19						20	22	
	dxn	14x4			19x4			19x8		23x8	28x8		28x12	
Ağırlık / Weight	Kg	2	3	4	6	7	9,5	15	20	26	36	48	85	
Filtre / Filter		30 Mesh (600 Mikron-Micron)						14 Mesh (1500 Mikron-Micron)						