

METAL KÖRÜKLÜ KOMPANSATÖR (SABİT FLANŞLI, LAYNERSİZ, PN 16)

-METAL BELLOWS EXPANSION JOINTS (FIXED FLANGED, WITHOUT LINER, PN 16)

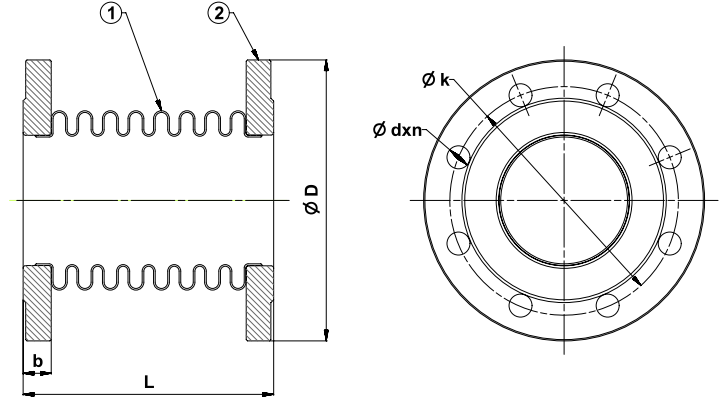

T-1910 Movement 30mm (-20 ... +10 mm) DN 25 - 250
T-1930 Movement 60mm (-40 ... +20 mm) DN 50 - 250



Genel Özellikler / General Specifications

Çalışma Sıcaklık Aralığı / Working Temperature : -80 ... +420°C (16 Bar)

Standartlar / Standards

Sertifikalar / Certificates :

Tasarım / Design : TS 10880

Bağlantı Boyutları / Connection Dimensions : TS EN 1092-1 (PN 16)

Testler / Tests : TS EN 12266-1

Malzeme Özellikleri / Material Specifications	No	Parça Adı / Part Name	Malzeme / Material
	1	Körük / Bellow	X5CrNi18 10 - AISI304 - Paslanmaz Çelik / Stainless Steel
2	Flanş / Flange	St37 - Çelik / Steel	

Uygulamalar / Applications

Sıcak ve soğuk su sistemleri, basınçlı hava, kızgın su, buhar, kızgın buhar, kızgın yağ sistemleri
Hot and cold water systems, compressed air, superheated water, steam, superheated steam systems, superheated oil systems

Ölçüler / Dimensions	Anma Basıncı / Nominal Pressure	16 Bar											
	Anma Çapı / Nominal Diameter	DN	25	32	40	50	65	80	100	125	150	200	250
T-1910	L 30mm (-20 ... +10mm)		110	120		125	115	120	130	150			
	L 60mm (-40 ... +20mm)					180	175	180	190	185	200	220	
T-1910	Eksenel Hareket / Axial Movement		30mm (-20 ... +10mm)										
			60mm (-40 ... +20mm)										
Vana Boyutları / Valve Dimensions (mm)	$\varnothing D$		115	140	150	165	185	200	220	250	285	340	405
	k		85	100	110	125	145	160	180	210	240	295	355
	b		16	18	20			22		24	26	28	
	dxn		14x4		18x4			18x8		22x8	22x12	26x12	